

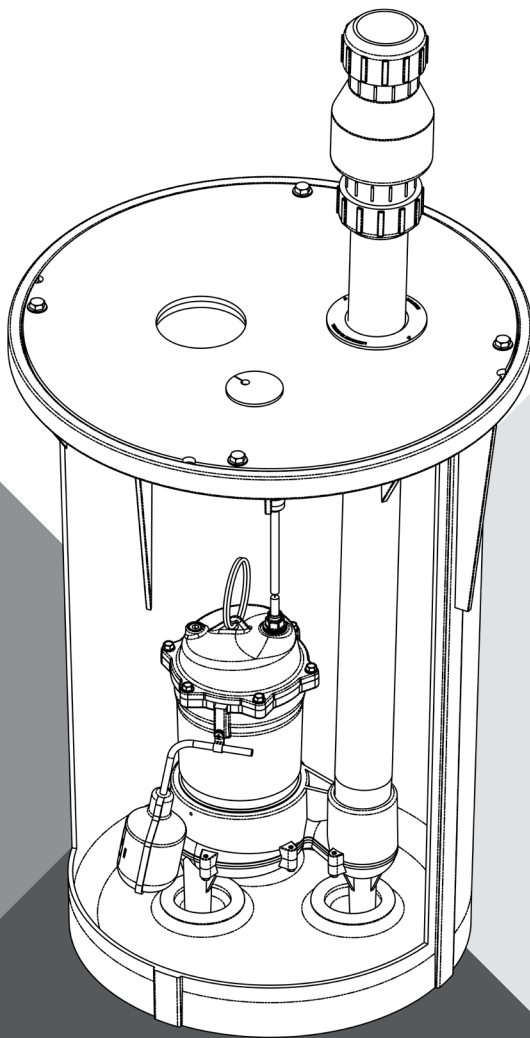

BASIN ASSEMBLY PUMP MODEL CMV1830



INSTALLATION AND OPERATION MANUAL

pentair.com

TABLE OF CONTENTS

INTRODUCTION

Safety Instructions.....	3
Installation.....	4-5
Repair Parts Index	6
Warranty.....	7

SAFETY INSTRUCTIONS

SAFETY SYMBOLS

 This is the safety alert symbol. When you see this symbol on your pump or in this manual, look for one of the following signal words and be alert to the potential for personal injury:

 **DANGER** warns about hazards that will cause serious personal injury, death or major property damage if ignored.

 **WARNING** warns about hazards that can cause serious personal injury, death or major property damage if ignored.

 **CAUTION** warns about hazards that will or can cause minor personal injury or property damage if ignored.

The word **NOTICE** indicates special instructions that are important but not related to hazards.

GENERAL SAFETY

- ◆ Carefully read and follow all safety instructions in this manual and on the unit itself.
- ◆ Follow all applicable local and state codes and regulations.
- ◆ Keep safety labels in good condition, replacing any missing or damaged labels.
- ◆ Vent sewage or septic tank according to local codes.
- ◆ Do not install pump in any location classified as hazardous by National Electrical Code, ANSI/NFPA 80-1984 or the Canadian Electrical Code.

 **WARNING HAZARDOUS VOLTAGE. CAN SHOCK, BURN, OR KILL.**

During operation the pump is in water. To avoid fatal shocks, proceed as follows if pump needs servicing:

- ◆ Do not smoke or use devices that can generate sparks in a septic (gaseous) environment.
- ◆ Disconnect power to outlet box before unplugging pump.
- ◆ Take extreme care when changing fuses. Do not stand in water or put your finger in the fuse socket.
- ◆ Do not modify the cord or plug. When using cord and plug, use a grounded outlet only. When wiring to a system control, connect ground lead to the system ground.
- ◆ Be sure that construction and access to septic sumps conform with all OSHA requirements.
- ◆ Do not run the pump dry. Dry running can overheat the pump, (causing burns to anyone handling it) and will void the warranty.
- ◆ The pump normally runs hot. To avoid burns when servicing pump, allow it to cool for 20 minutes after shutdown before handling it.
- ◆ The pump is permanently lubricated. No oiling or greasing is required in normal operation. For overhaul, see instructions under this manual's Maintenance section.

CALIFORNIA PROPOSITION 65 WARNING:

 **WARNING** This product and related accessories contain chemicals known to the State of California to cause cancer, birth defects or other reproductive harm.

ELECTRICAL SAFETY

 **DANGER HAZARDOUS VOLTAGE. CAN SHOCK, BURN, OR KILL.**

When installing, operating, or servicing this pump, follow the safety instructions listed below.

- ◆ DO NOT splice the electrical power cord.
- ◆ DO NOT allow the plug on the end of the electrical cord to be submerged.
- ◆ DO NOT use extension cords. They are a fire hazard and can reduce voltage sufficiently to prevent pumping and/or damage motor.
- ◆ DO NOT handle or service the pump while it is connected to the power supply.
- ◆ DO NOT remove the grounding prong from the plug or modify the plug. To protect against electrical shock, the power cord is a three-wire conductor and includes a 3-prong grounded plug. Plug the pump into a 3-wire, grounded, grounding-type receptacle. Connect the pump according to the NEC or CEC and local codes.
- ◆ BE SURE that power supply information (Voltage/ Hertz/ Phase) on pump motor nameplate matches incoming power supply exactly. Install pump according to all electrical codes that apply.

Before installing your pump, check carefully for shipping damage. Any claim for shipping damage must be made with your supplier at the point of purchase. **The manufacturer cannot make shipping damage adjustments.**

INSTALLATION

Your CMV1830 is designed to operate automatically or manually and for simple and quick installation. The pre-set fluid level control allows for efficient operation when installed in a standard 18" x 30" sewage basin.

ELECTRICAL INFORMATION

⚠ WARNING Risk of electrical shock – This pump is supplied with a grounding conductor and grounding type attachment plug. To reduce the risk of electrical shock, connect only to a properly grounded grounding type receptacle. This pump has not been investigated for use in swimming pool/fountain areas. Read instructions before installing pump.

Never touch the sewage pump, switch or discharge pipe when the pump is connected to electrical power.

Check the electrical circuit to make sure it meets the voltage and amperage requirement listed on the motor name plate.

Your electrical service outlet should meet the National Electric Code and/or local codes. Your pump should have a separate branch circuit, properly fused and grounded. The outlet should be 4' above the floor and close enough to your pump that the original cord can reach it. **Never use an extension cord.**

Plug the switch power cord into a properly grounded outlet. Plug the pump power cord into the back of the switch cord plug. Tape the power cords to the discharge pipe every 12 inches to make sure any movement will not damage the insulation. Do a neat job!

To test the system, add water to the sewage basin until the float switch operates normally.

Your pump has thermal overload protection. If the impeller becomes locked because of a foreign object, the motor will overheat and the thermal overload switch will cut off the electricity. Unplug pump and remove the foreign object immediately. See that the impeller turns freely.

⚠ CAUTION Always disconnect your pump and switch from the electrical power source before doing any maintenance.

INSTALLATION

This is a sewage handling pump and must be vented in accordance with local plumbing codes. This pump is not to be installed in locations classified as hazardous in accordance with National Electric Code, ANSI/NFPA 70.

The motor in your new submersible sewage pump is oil-filled for efficient operation. **DO NOT loosen the three motor housing screws.**

Place sewage pump on the bottom of the basin and position it to allow float to rise in center of basin (see Figure 1). Check that nothing interferes with the float switch.

Slip cover over discharge pipe and power cord. Bolt cover securely to basin (be sure to use a cover gasket). Install discharge compression fitting and cord seal grommet.

CHECK VALVE

A properly designed full-flow check valve **MUST** be used on every installation. A series CV-200P is provided. It eliminates back-flow, reduces vibration and acts as a pipe union for easy servicing. Install on discharge pipe (make certain that arrow on valve body points in flow direction). Connect outlet of check valve to the plumbing line leading to the sanitary sewer system.

SWITCH ADJUSTMENT AND REPLACEMENT INSTRUCTIONS

⚠ CAUTION Always disconnect the pump and switch from the electrical power source before doing any maintenance! This pumps is equipped with a float switch and does not control both sides of the electrical circuit. To reduce the risk of electrical shock it is essential that it be wired in series with the hot side of the electrical circuit. Make sure your outlets are wired according to your local electrical code.

1. Inspect the pump to be certain that there are no rocks, lint, etc. clogging the openings where water enters the pump housing. Remove any debris. Check to see that the impeller turns freely.
2. Plug the pump power cord into a properly grounded, 3 hole outlet. If the pump works, (impeller turns and air is blowing out of discharge opening), proceed to Step 3. **If the pump does not work, it must be replaced.**
3. If the pump works, (1) unplug pump and (2) replug into back of switch plug and (3) plug the assembly into the electrical outlet. Raise switch by hand to activate pump. If pump turns on, pump and switch are OK there is no need to replace. If pump does not turn on, the switch is defective and must be replaced. Proceed to step 4. Then, with a new switch, repeat step 3. If pump turns on, the problem is solved.
4. To replace switch, remove screw from tether clamp. In assembling new switch, position cable tie (17190A008) so the tether length is 2 7/8 -3". Tighten cable tie and cut off excess length. Mount tie to the pump with a # 10-24UNC x 1/2" long SST screw.

REPAIR PARTS INDEX

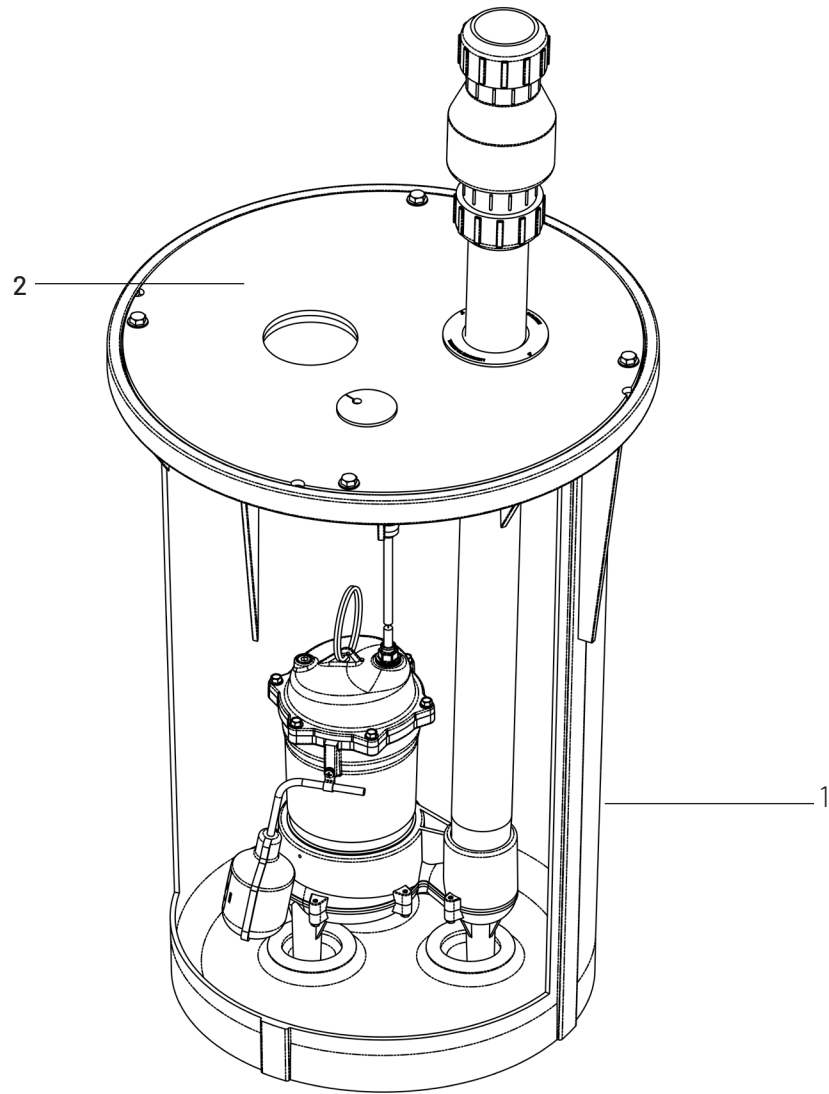

REF. NO.	PART NUMBER	DESCRIPTION
1	25533D100	Basin 18 x 30 Reg. Top for Solid Covers or Split Covers
1	25960D000	IAPMO Basin, 18 x 30 Reg. Top for Solid Covers (16) Hole (Optional)
2	25536C101	Cover, Solid, Domed Plastic, (4) Hole, 2" or 3" Vent
2	25536C010	Cover, Split, 2" Vent (Optional)
2	25536C011	Cover, Split, 3" Vent (Optional)
2	25961C401	IAPMO Cover, Solid, Steel (16) Hole, 2" or 3" Vent (Optional)

DIMENSION DATA

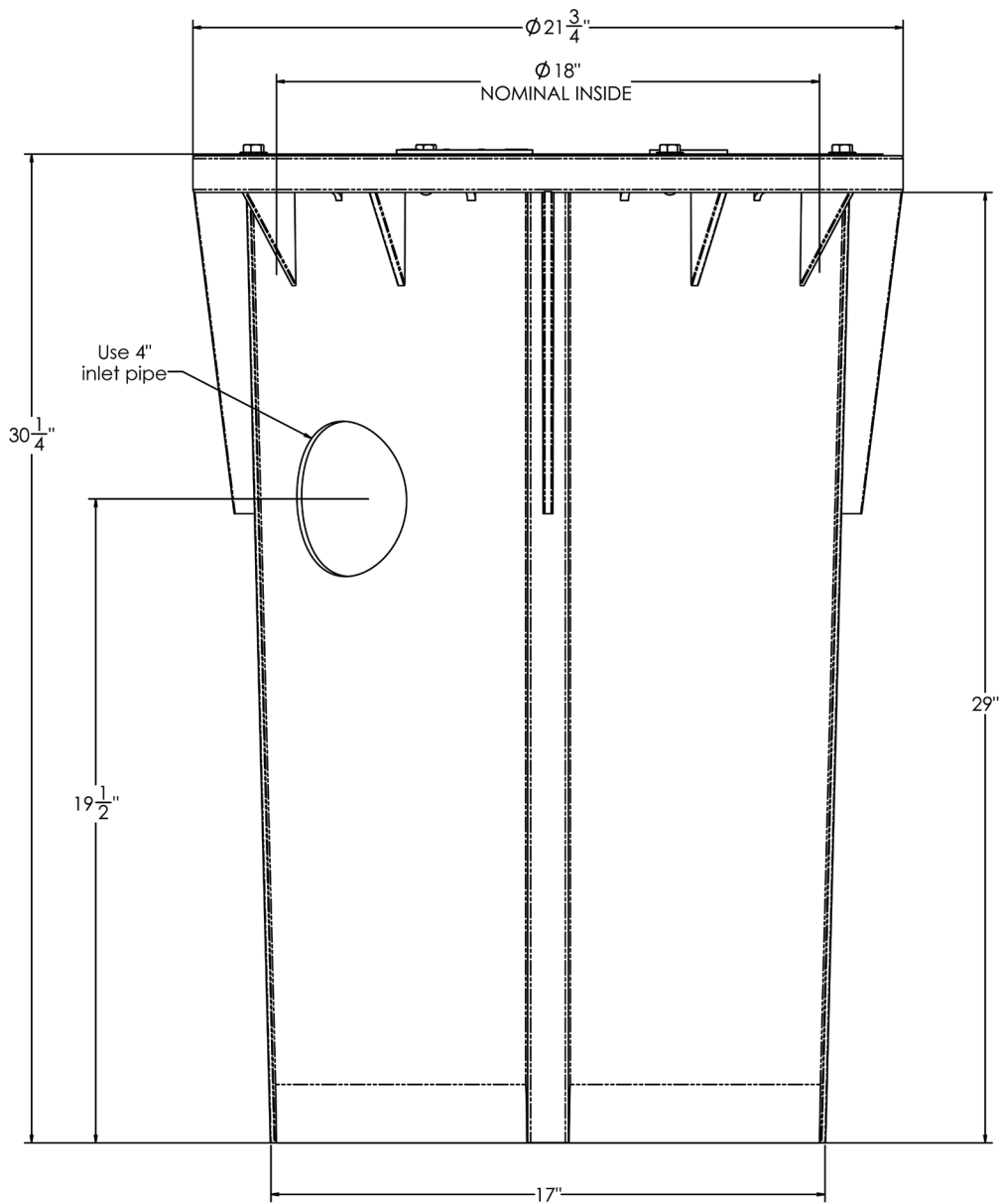

WARRANTY

During the time periods and subject to the conditions hereinafter set forth, Pentair Myers will repair or replace to the original user or consumer any portion of your new Pentair Myers product which proves defective due to defective materials or workmanship of Pentair Myers. Contact your nearest authorized Pentair Myers dealer for warranty service. At all times Pentair Myers shall have and possess the sole right and option to determine whether to repair or replace defective equipment, parts, or components. Damage due to lightning or conditions beyond the control of Pentair Myers is NOT COVERED BY THIS WARRANTY.

WARRANTY PERIOD

PUMPS: 12 months from date of installation or 18 months from date of manufacture, whichever occurs first.

LABOR, ETC. COSTS: Pentair Myers shall in no event be responsible or liable for the cost of field labor or other charges incurred by any customer in removing and/or reaffixing any Pentair Myers product, part, or component thereof.

THIS WARRANTY WILL NOT APPLY: (a) to defects or malfunctions resulting from failure to properly install, operate or maintain the unit in accordance with printed instructions provided; (b) to failures resulting from abuse, accident, or negligence; (c) to normal maintenance services and the parts used in connection with such service; (d) to units which are not installed in accordance with applicable local codes; ordinances, and good trade practices; (e) unit is used for purposes other than for what it was designed and manufactured, and (f) if three phase submersible motors are installed on a single phase power supply using a phase converted or if three phase power is supplied by only two transformers, making an open Delta system.

RETURNED OR REPLACED COMPONENTS

Any item to be replaced under this Warranty must be returned to Pentair Myers at Ashland, Ohio or such other place as Pentair Myers may designate, freight prepaid.

PRODUCT IMPROVEMENTS

Pentair Myers reserves the right to change or improve its products or any portions thereof without being obligated to provide such a change or improvement for units sold and/or shipped prior to such change or improvement.

WARRANTY EXCLUSIONS

As to any specific Pentair Myers product, after the expiration of the time period of the warranty applicable thereto as set forth under the heading "Warranty Periods" above, THERE WILL BE NO WARRANTIES INCLUDING ANY IMPLIED WARRANTIES OF MERCHANTABILITY OR FITNESS FOR ANY PARTICULAR PURPOSE.

Some states do not allow limitations on how long an implied warranty lasts, so the above limitation may not apply to you. No warranties or representations at any time made by any representative of Pentair Myers shall vary or expand the provisions hereof.

PRODUCT IMPROVEMENTS

IN NO EVENT SHALL PENTAIR MYERS BE LIABLE OR RESPONSIBLE FOR CONSEQUENTIAL, INCIDENTAL OR SPECIAL DAMAGES RESULTING FROM OR RELATED IN ANY MANNER TO ANY MYERS PRODUCT OR PARTS THEREOF.

Some states do not allow the exclusion or limitation of incidental or consequential damages, so the above limitation or exclusion may not apply to you.

This Warranty gives you specific legal rights and you may also have other rights which vary from state to state.

In the absence of other suitable proof of this installation date, the effective date of this warranty will be based upon the date of manufacture plus one year.

Direct all notices, etc. to: Warranty and Product Service Department, Pentair Myers, 1101 Myers Parkway, Ashland, Ohio 44805-1969.

DETERMINATION OF UNIT DATE OF MANUFACTURER:
Submersible sump pump (8-94) month and year stamped on pump nameplate; column sump pump month and year stamped on red warranty tag.

PENTAIR MYERS
293 Wright Street, Delavan, WI 53115
Phone: 888-987-8677 • Fax: 800-426-9446 • www.femyers.com
In Canada: 490 Pinebush Road, Unit 4, Cambridge, Ontario N1T 0A5
Phone: 800-363-7867 • Fax: 888-606-5484



AMERICAS
1101 Myers Parkway
Ashland, Ohio 44805
PH: 855-274-8947

CANADA
490 Pinebush Road,
Unit 4
Cambridge, Ontario,
Canada N1T 0A5
PH: 800-363-7867

pentair.com