

# 19 Gallon Precharged Pressure Tanks

Vertical or Horizontal Design

## Factory Precharged to 40 PSI for Efficiency

Extends pump life by providing more water between pump cycles compared to standard tanks

## Heavy-Gauge Steel Construction

For maximum durability and extended life

## Precision Press Fit Design

Minimizes gaps between components, reducing corrosion and seam leaks

## Convenient Size

Ideal for household applications

## Easy Maintenance

NSF-61-approved tank  
Replaceable air/water separator



**19 GAL** FP7110T

**19 GAL** FP7110TH

**19 GAL** FP7110

### PERFORMANCE

MODEL	STANDARD TANK EQUIVALENCY	ACTUAL TANK CAPACITY	DRAWDOWN COMPARISON						STYLE	PLUMBING CONNECTION
			PRECHARGED			STANDARD				
			20/40	30/50	40/60	20/40	30/50	40/60		
FP7110T	42 Gallons	19 Gallons	6.9	5.9	5.0	6.5	4.3	3.0	Vertical	1"
FP7110TH	42 Gallons	19 Gallons	6.9	5.9	5.0	6.5	4.3	3.0	Horizontal	1"
FP7110	42 Gallons	19 Gallons	6.9	5.9	5.0	6.5	4.3	3.0	Vertical	1"

MODEL	WARRANTY	UPC	CARTON DIMENSIONS	PALLET QTY.	WEIGHT
FP7110T	5 YEAR	022315101203	16.75" x 16.75" x 29.313"	4	36.5 LBS.
FP7110TH	5 YEAR	022315101388	18.31" x 16.813" x 27.313"	6	38.5 LBS.
FP7110	5 YEAR	022315101098	14.063" x 12.813" x 17.313"	18	18.9 LBS.

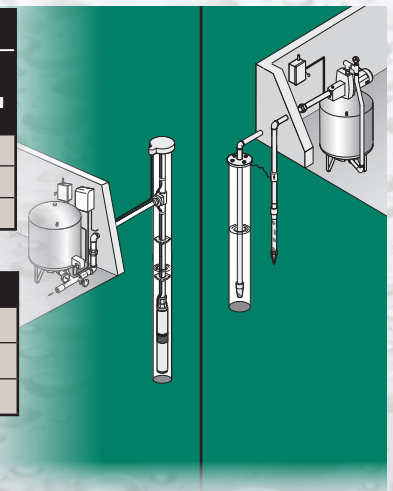

Includes:

Detailed owner's manual