

FRESHPOINT[®] GRO-475BP

FOUR STAGE REVERSE OSMOSIS SYSTEM WITH PUMP



APPLICATIONS

- ◆ Undersink

FEATURES • BENEFITS

- ◆ Reduces more than 90% of contaminants found in water
- ◆ Effortless click-in cartridge change-outs
- ◆ Color-coded cartridges help maintain proper filter sequence
- ◆ 3/8" push fittings for easy installation
- ◆ High efficiency membrane technology delivers up to 75 gallons per day
- ◆ Integrated booster pump for low water pressure applications, increasing tank fill rate

INSTALLATION TIPS

- ◆ Choose a mounting location suitable to support the full weight of the system when operating.
- ◆ Install vertically with the cartridge hanging down.
- ◆ System may be installed with cartridge flush to the baseboard if desired as the mechanical assist lever pushes cartridges straight out.
- ◆ Electrical access required for installation.

OPERATION TIPS

- ◆ Replace pre/post filters every year and RO membrane every 18 months.
- ◆ Integrated booster pump for low water pressure applications or to increase flow.
- ◆ Place replacement cartridges in proper sequence utilizing color-coded shapes.
- ◆ System designed with integrated check valves so cold water line does not need to be shut-off to perform cartridge change-outs.

INCLUDES

- ◆ Air gap side faucet
- ◆ Installation kit
- ◆ Installation and operation manual
- ◆ 4.4 gallon storage tank

FRESHPOINT GRO-475BP FOUR STAGE REVERSE OSMOSIS SYSTEM WITH PUMP

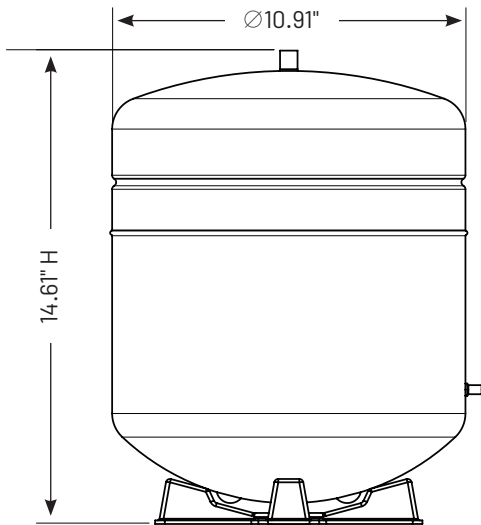
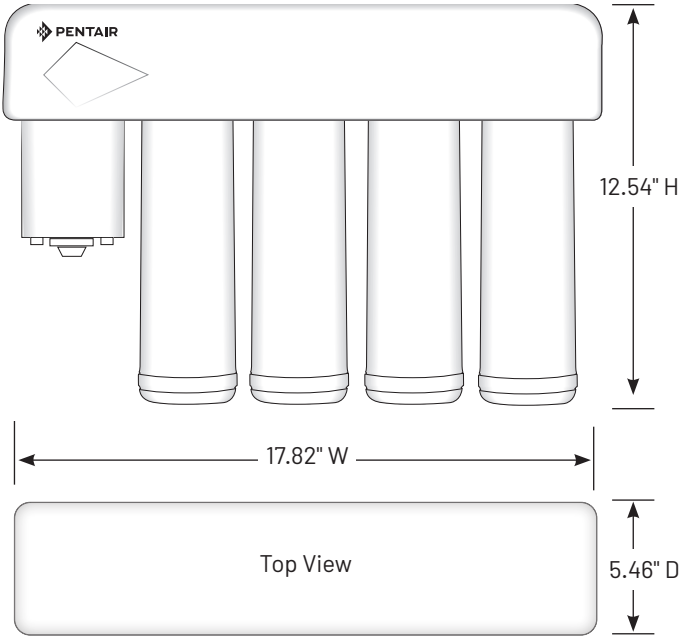

SPECIFICATIONS

- ◆ **System** (Model/Part No.)
GRO-475BP/161114
 - ◆ **Inlet Size**
3/8" QC
 - ◆ **Dimensions**
17.82" W x 5.46" D x 12.54" H
(453 mm x 139 mm x 319 mm)
 - ◆ **System Weight**
12.75 lbs
 - ◆ **Contaminant Reduction**
Chlorine Taste and Odor, Nominal Particulate, Class I, Atrazine, Lead, Lindane, Arsenic (Pentavalent) <= 50 ppb, Barium, Cadmium, Chromium (Hexavalent), Chromium (Trivalent), Copper, Fluoride, Radium 226/228, Selenium, Turbidity, TDS, Cyst: NSF/ANSI Standard 53 certified to reduce cysts such as *Cryptosporidium* and *Giardia* by mechanical means.
 - ◆ **TDS Rejection**
98%
 - ◆ **Approximate Filter Life***
Pre/post filters: 1 year
RO Membrane: 18 months
 - ◆ **System Production Rate**
94.38 gpd (357.26 Lpd)
(Side Faucet Required)
 - ◆ **Recovery Rating**
55.82%
 - ◆ **Certifications**
NSF/ANSI Standards 42/53/58
CSA Standard B483.1
 - ◆ **Feed Pressure Range**
10 - 60 psi (0.68 - 4.13 bar)
 - ◆ **Temperature Range**
40 - 100°F (4.4 - 37.8°C)
 - ◆ **Replacement Cartridges**
(Model/Part No.)
F1GC-RC/655117-96
FDF1-RC/655123-96
F1B1-RC/655120-96
GRO75-RC/655122-96
- * Filter life dependent on gallon usage and overall incoming water quality.

EPA Est. No. 082989-CHN-001



The Model GRO-475BP is Tested and Certified by NSF International against NSF/ANSI Standards 42, 53, 58 and CSA B483.1 for the reduction of substances specified in the service manual or at www.nsf.org.



13845 Bishops Dr. | Suite 200 | Brookfield, WI 53005 | United States
P: 262.238.4400 | Customer Service: 800.279.9404 | tech-support@pentair.com | pentair.com

§For a detailed list of where Pentair trademarks are registered, please visit www.pentair.com/registrations. Pentair trademarks and logos are owned by Pentair plc or its affiliates. Third party registered and unregistered trademarks and logos are the property of their respective owners.

© 2020 Pentair Residential Filtration, LLC. All rights reserved.

4004812 Rev C FE20