

Oil Detection System

Owner and Operational Manual



PENTATEK
Pentair Water

Introduction

Read all instructions thoroughly. Installation of the Oil Detection System must comply with all Federal, State and Local Codes, Regulations and Practices. The Oil Detection System must be installed by qualified personnel familiar with all applicable local electrical and mechanical codes. Refer to the National Electrical Code (NFPA 70). Failure to properly install and test this product can result in personal injury or equipment malfunction.

The Oil Detection System is designed and approved for the safe operation of pumping, alarming and monitoring of elevator sump pits, transformer vaults and leachate well applications. The Oil Detection System will activate a pump to remove water from elevator pits in accordance with ASME A17.1. The Oil Detection System stops the pump before oil or other harmful substances enter our water supply. Indicator lights will illuminate on the control panel for the following: power, pump running, high alarm, high oil. The panel has a set of auxiliary contacts that activate on power loss or high Oil/Water conditions. These contacts can be connected to the Oil Detection System remote panel which contains audio/visual alarming along with auxiliary contacts for connection to building automation system or SCADA system.

Safety Guidelines



1. DO NOT USE WITH FLAMMABLE OR EXPLOSIVE FLUIDS SUCH AS GASOLINE, FUEL OIL, KEROSENE, ETC. DO NOT USE IN EXPLOSIVE ATMOSPHERES. PROBE/FLOAT SWITCH SHOULD ONLY BE USED WITH WATER.
2. DO NOT HANDLE THE OIL DETECTION SYSTEM WITH WET HANDS OR WHEN STANDING ON A WET OR DAMP SURFACE OR IN WATER.
3. DISCONNECT ALL ELECTRICAL SERVICE BEFORE WORKING OR HANDLING THE OIL ALERT SYSTEM.
4. INCOMING VOLTAGE MUST MATCH THE OIL DETECTION SYSTEM'S VOLTAGE.
5. TO PREVENT ELECTRICAL SHOCK AND EQUIPMENT MALFUNCTION, USE ONLY WITH A PUMP SUPPLIED WITH A GROUNDING CONDUCTOR AND GROUNDING-TYPE ATTACHMENT PLUG. BE CERTAIN TO PLUG THE OIL DETECTION SYSTEM PANEL INTO A PROPERLY GROUNDED, GROUNDING-TYPE RECEPTACLE.
6. CONTROL PANEL AND ALARM MUST BE MOUNTED INDOORS. FOR OUTDOOR APPLICATIONS CONSULT FACTORY.
7. SECURE LEVEL SENSOR ON DISCHARGE PIPE AT A LEVEL THAT GUARANTEES PARTIAL PUMP SUBMERGANCE WHEN WATER LEVEL IS JUST BELOW THE "OFF" PROBE (THE LONGEST PROBE). (See Figure 5 on page 3 of this manual). FAILURE TO PROPERLY MOUNT THE LEVEL SENSOR MAY CAUSE THE PUMP TO ACTIVATE EVEN WHEN OIL IS PRESENT IN THE SUMP.
8. CAUTION! REMOVE ANY FLOAT SWITCH THAT IS CURRENTLY USED OR SUPPLIED WITH THE PUMP. IF THE FLOAT CANNOT BE REMOVED, SECURE SWITCH SO THAT IT IS ALWAYS ON.

Part Numbers

EPC-115 - Oil Detection System 115 volt Oil Sensor Control System (Control Panel, Alarm Panel, Level Sensor). NEMA 1.



PENTATEK
Pentair Water

Page 1 of 6
DWG# EPC-115

Oil Detection System

Owner and Operational Manual



PENTEK
Pentair Water

Description of Operation

On water rise, level reaches pump “start” probe to start the pump. Pump will remain on until level is below “off” probe. The “off” probe senses air or oil and turns the pump off so the oil layer will not be pumped out of the sump. If the liquid level reaches alarm probe and mechanical float, the system will differentiate between water and oil and activate the remote alarm.

Installation of the Control Panel

1. It is highly recommended to mount the control panel in the same area as the sump pump to eliminate any splicing of sensor and pump wires. See “Installation of Preset Level Sensor Holder” for more information on splicing.
2. Determine mounting location for the control panel. Mount panel at the desired location making sure the mounting location of the control panel is within 6 feet of electrical receptacle.
3. Plug pump cable into control panel receptacle cable. Plug power cable into receptacle only when ready for testing. See Testing System installation.
4. If the panel is to be installed with conduit, the cables and cord seals must first be removed. Please make note of wire locations. The incoming power 115V is connected to L1 and L2 of the contactor, pump receptacle is T1 and T2 on the contactor. Low voltage cable from the level sensing module: green - TB1 off probe, yellow - TB2 start probe, red - TB3 alarm probe, white - TB4 float, black - TB5 float. Low voltage auxiliary contacts are TB6 and TB7. Do not mix low voltage probe wires or auxiliary contacts in high voltage conduits. See figure 3 and figure 6.

Figure 1

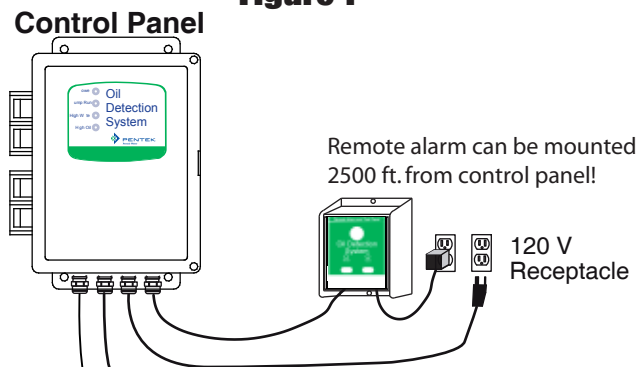

Remote Alarm has additional auxiliary contacts for building alarm system.

Elevator Sump

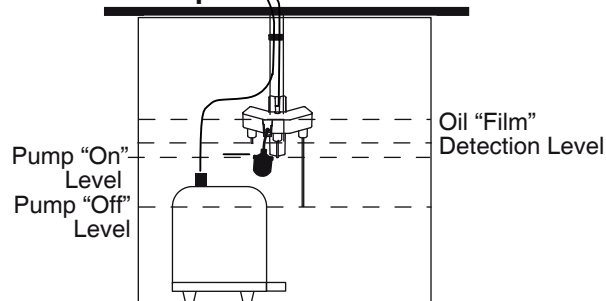

Figure 2

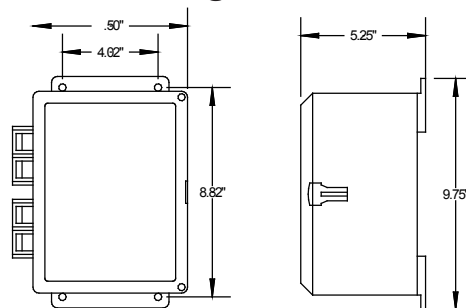
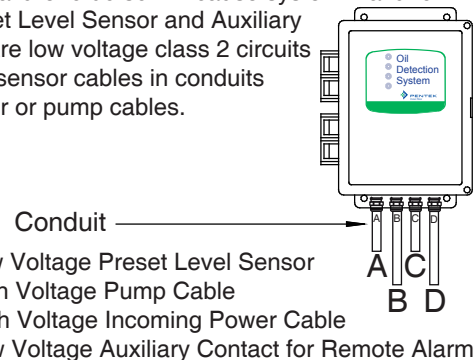

Figure 3



Warning – Do not mix high and low voltage circuits in the same conduit, failure to do so will cause system malfunction. The Preset Level Sensor and Auxiliary Contact wires are low voltage class 2 circuits - Do not install sensor cables in conduits with main power or pump cables.



PENTEK
Pentair Water

Oil Detection System

Owner and Operational Manual



PENTEK
Pentair Water

Installation of Preset Level Sensor Holder

1. Review figures 4, 5 and 6.
2. Attach sensor holder to discharge pipe or separate pipe (mounted to side wall) using the stainless steel pipe clamp. Make sure sensor is clear of inlet water and at least 1" to 2" away from any conductive material. Make sure the bottom probe (off level) is at the same height as the top of the pump or just slightly below ensuring submergence of the pump. See figure 5.
3. Route the five conductor cable to the control panel through the liquid tight cord connector and tighten compression nut.
4. Connect the wires from the level sensor to the terminal strip inside the control panel. See figure 6.
5. If splicing on sensor cable is required:
 - A. For any splicing longer than 100 feet, consult factory.
 - B. Use liquid tight junction boxes and appropriate liquid tight connectors and/or conduit.
 - C. Do not mix high and low voltage circuits in same junction box.
 - D. For level sensor splice, it is recommended to use 5 conductor, 18 AWG shielded cable. Only ground the shield on one end of the cable – easiest to ground shield wire in panel to the ground lug.

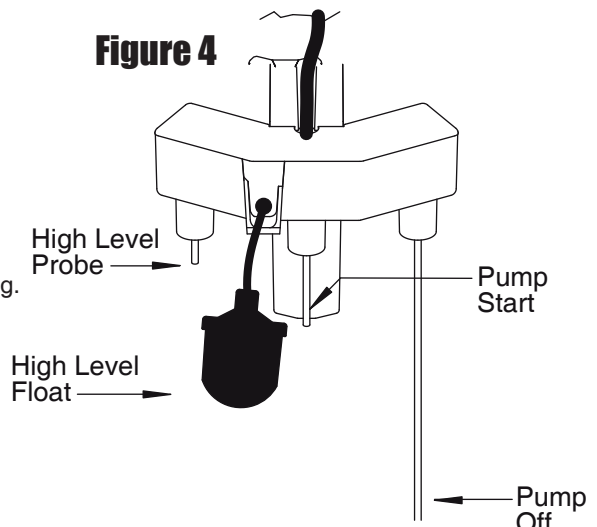
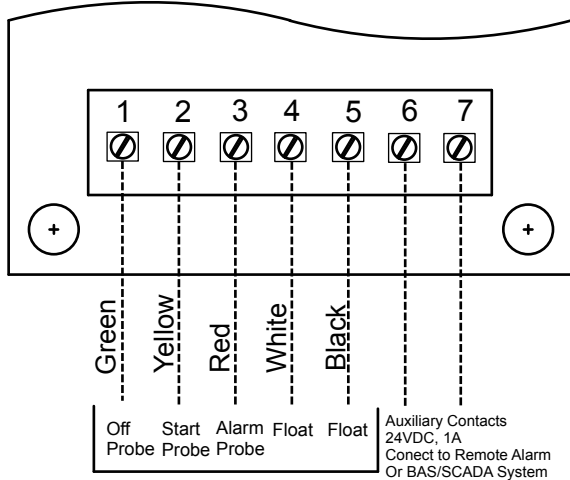
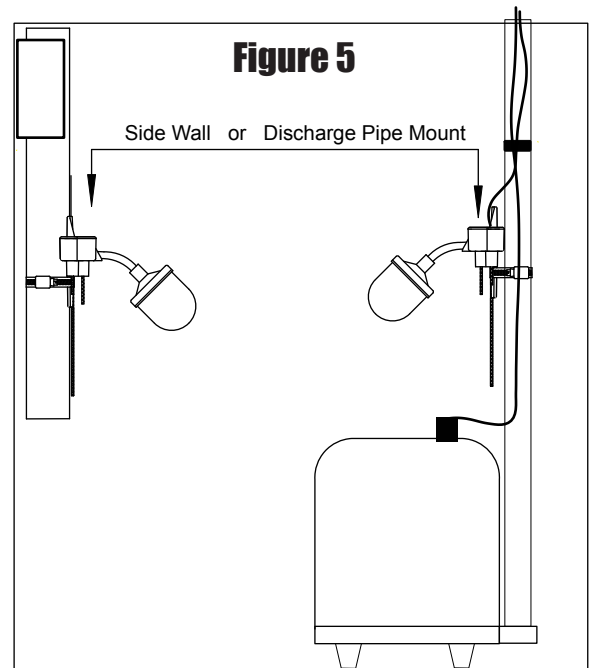

Figure 6
Circuit Board



5 Conductor Cable from Preset Level Sensor



PENTEK
Pentair Water

Oil Detection System

Owner and Operational Manual



PENTEK
Pentair Water

Installation of the Alarm Panel

The Oil Detection System Remote Alarm Panel is powered by 120 VAC coming from standard wall outlets and is transformed to 9VDC. Installing a 9 Volt battery provides batter back-up.

When the Oil Detection System Control Panel's Auxiliary Contacts "close" the buzzer and light will turn "on" and the alarm panel's auxiliary contacts will be activated. Pressing the "silence switch deactivates the buzzer and auxiliary contacts. When the Oil Detection System Control Panel's Auxiliary Contacts reset, the remote alarm panel will automatically reset itself.

Test product weekly. Make sure the green "power on" light is "on". Press the "Test" switch; the red alarm light and buzzer should turn "on". If the battery back up system is utilized, unplug the wall mount power supply (the green light will be off). Now press "Test" switch; the red alarm light and buzzer will turn "on". If the buzzer sounds less loudly than when tested with the normal power supply, then replace the battery.

1. To install/replace the battery for the backup power feature, remove the two side screws and install 9 VDC battery (Duracell model MX 1604B2). After installing battery, press the test button to activate the alarm to make sure the battery works properly. Reinstall side screws. See Figure 7
2. Determine mounting location for the Alarm Panel. Make sure power outlet is withing 6 feet of the alarm. Make sure the outlet is on a separate circuit breaker from any other device and not on a switched receptacle to maintain power integrity. Mount the alarm using two #8 X 1 1/4" self tapping screws (not included). Use #8 plastic anchor if mounting to sheet rock. See Figure 8. The alarm can be mounted up to 1000 feet from the panel using 18 ga wire.
3. If Auxiliary Contacts are sued, continue; otherwise go to step 4. Remove cover from base and remove 1/2" electrical knockout from base. Use 16-2 AWG stranded wire - make sure there is at least 6" of wire inside of enclosure. Install a 1/2" strain relief with jam nut. Connect wires for required application using wire nuts. Caution! - When installing wires, route all wires away from sharp objects and internal components. See figure 9 & 10.
4. There are two terminals on the bottom of the alarm panel. Connect a wire from the first terminal to the CONTROL PANEL terminal #6 and connect another wire from the second terminal of the alarm panel to CONTROL PANEL terminal #7. See Figure 8.
5. Plug the power supply into a 120VAC, 50/60 Hz standard wall outlet. For UL applications, remove center screw on receptacle and place cord from wallmount transformer inside the plastic cord holder. Secure plastic cord holder to the receptacle by reinstalling screw to the center hole of receptacle. See Figure 8. For Canadian applications DO NOT INSTALL Plastic Cord Holder! The green "Normal" light should come on.
6. Test the system by pressing the "Test" switch. The buzzer and the red warning light will be "on". The green "Normal" light will be "off". While holding the "Test" switch, press the "Silence" switch. The buzzer will silence, but the alarm light will remain "on". Let go of the "Test" switch and the alarm light will turn "off" and the green "Normal" light will turn "On" indicating the system is no in a normal condition.

Figure 7 - Installing/Replacing Battery

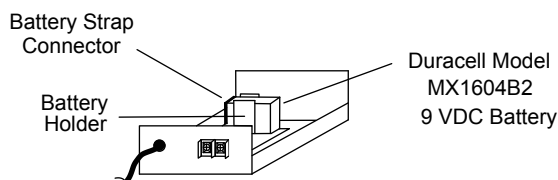

Figure 8 - Mounting

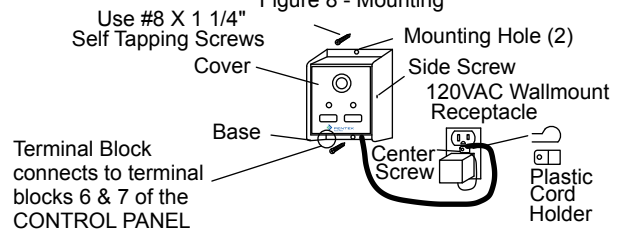

Figure 9 - Installing Field Wiring for Auxiliary Contacts

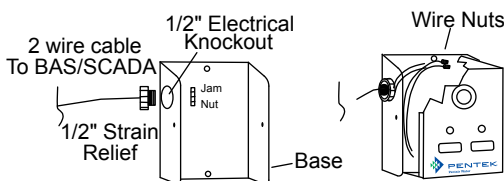
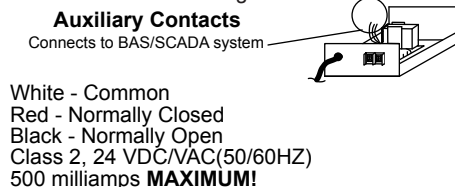

Figure 10



PENTEK
Pentair Water

293 S. Wright St, Delavan, WI 53115 Phone: 1-866-973-6835 Fax: 800-426-9446

Oil Detection System

Owner and Operational Manual



PENTTEK
Pentair Water

Upon complete installation of controls, pump and piping, the complete system should be tested for quality assurance.

1. Test high oil circuit by lifting the float switch with the sump empty of water. Oil is non conductive like “air”, and when the float is lifted only the HIGH OIL indicator will be illuminated. The auxiliary contacts in the control panel and the remote alarm will activate.
2. Test a pump cycle by slowly filling tank with water. Stop filling tank with water when the level touches middle probe. When the water touches the middle probe, pump should start and pump down to the bottom probe at which time the pump will stop. Check discharge plumbing for leaks and make sure discharge is going to the correct area.
3. Test high water circuit. Unplug the pump from the control panel and slowly fill the tank until the water level just touches the upper probe. When the water touches the upper probe, the HIGH WATER indicator will be illuminated. The auxiliary contacts in the control panel and the remote alarm will activate.
4. Test the remote alarm for power loss. Unplug the power cord on the control panel. The auxiliary contacts will close and the remote alarm will activate.

Testing panel - Using 5 gallon pail.

If it is not possible to test the complete system outlined above, then test the panel operation using a 5 gallon pail filled with water. The system requires a temporary ground wire run from the control panel into the liquid in the pail for correct operation.

1. Run Temporary Ground wire (14 AWG Copper Wire) from the ground lug inside panel and into the pail of water. Make sure at least ½” of copper wire is exposed and immersed in the water.
2. Before lowering the sensor probe into the pail, lift the float switch, the HIGH OIL indicator will be illuminated. The auxiliary contacts in the control panel and the remote alarm will activate.
3. Lower the sensor probe into the bucket of water slowly so that the longest probe is immersed in the water. Slowly continue to lower so the middle probe touches the water, the pump should activate. While the pump is activated, slowly remove the sensor probe out of the water until the longest probe is no longer in the water, the pump should turn off. Repeat a couple of times for quality assurance.
4. Lower the sensor probe into the bucket of water slowly so that the longest probe and the middle probe are immersed in water, the pump will activate. Continue to lower sensor probe so that water touches the shortest probe, the HIGH WATER indicator will be illuminated. The auxiliary contacts in the control panel and the remote alarm will activate.
5. This completes testing. Remove temporary ground from panel and retighten ground lug with all the green wires. Return to manual for “Installation of Preset Level Sensor Holder”.

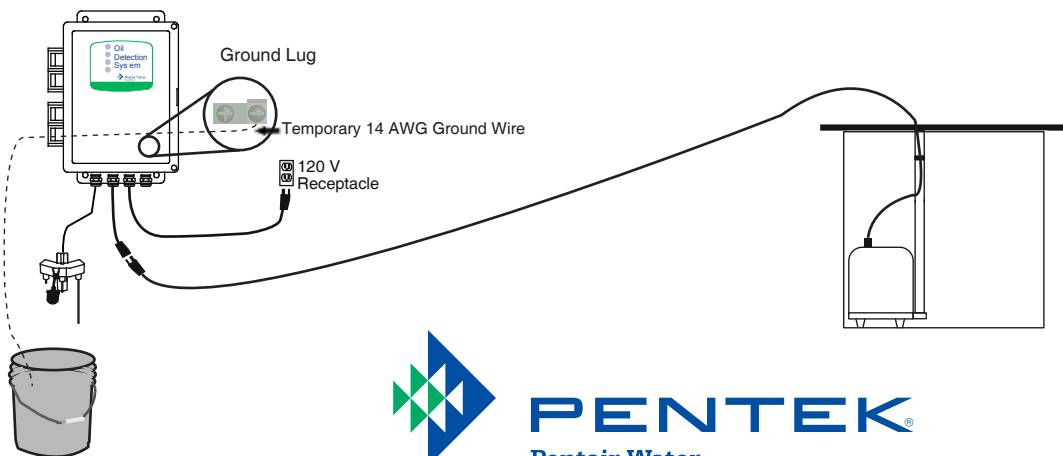

PENTTEK
Pentair Water

293 S. Wright St, Delavan, WI 53115 Phone: 1-866-973-6835 Fax: 800-426-9446

Page 5 of 6
DWG# EPC-115

Oil Detection System

Owner and Operational Manual



PENTEK[®]
Pentair Water

Maintenance

1. The preset level control must be kept clean and free of rust, mud, soap or any conductive material.
2. Every year clean probes keeping them free of debris, calcium or iron deposits.
3. Fuses in control panel are 5mm X 20mm 1/2amp for F1 and 5mm X 20mm 1amp for F2.
4. Every year replace 9 Volt Battery in Remote Alarm.

Trouble Shooting

Symptom	Possible Cause	Action
Pump does not run	Panel Power Cord Unplugged Pump not plugged into panel Defective Contactor Loose level sensor wires Pump failure	Plug in Outlet, Check Power Plug pump to panel plug Replace Contactor Tighten connections Replace pump
Pump turns off before bottom probe	Poor pump ground or system ground	Check grounding system



PENTEK[®]
Pentair Water

293 S. Wright St, Delavan, WI 53115 Phone: 1-866-973-6835 Fax: 800-426-9446

Page 6 of 6
DWG# EPC-115