

HYDROMATIC® HP33/HP50 SUMP PUMPS

APPLICATIONS

Basement sumps, dewatering, light effluent, water transfer

SPECIFICATIONS

Capacities	HP33	48 GPM (182 LPM)
	HP50	62 GPM (235 LPM)
Shut-off Head	up to 32' (9.8 m)	
Operation	On: 9" (229 mm) Off: 4" (102 mm)	
Operation	Automatic	
Solids Handling	1/2" (12.7 mm)	
Liquids Handling	Drainage effluent	
Continuous Liquid Temp	130°F (54°C)	
Motor Electrical Data	1/3 HP, 9.8A; 1/2 HP, 12A; shaded pole with thermal overload protection, 115V, 1Ø, 60Hz, 1550 RPM	
Acceptable pH Range	6-9	
Shaft Seal	Carbon and ceramic	
Housing/Volute	Heavy cast iron	
Volute Base	Fiberglass reinforced polypropylene	
Impeller	Fiberglass-reinforced Noryl® with threaded brass insert	
Exterior Hardware	Stainless steel	
Power Cord	10' (3 m), 16/3, SJTW-A, SJTW	
Discharge, NPT	1-1/2" (50.8 mm)	
Min. Sump Diameter	10" (25.4 cm)	

PERFORMANCE

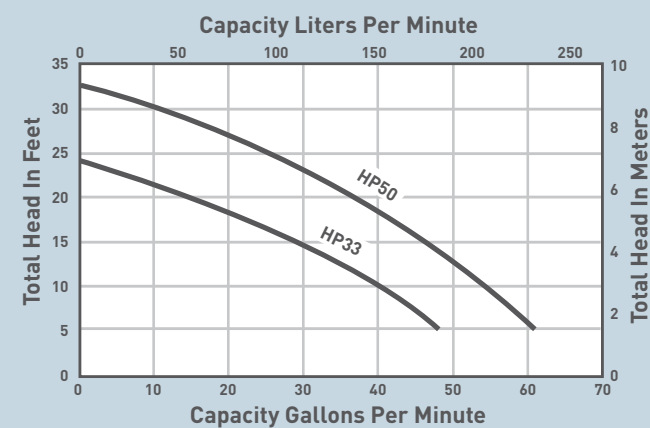

INTRODUCING THE DYNAMIC DUO, EXCLUSIVELY FROM HYDROMATIC.

The HYDROMATIC® HP33 and HP50 are rugged cast iron sump pumps featuring a vortex impeller that provides solids-handling capability up to 1/2". Product is available in 1/3 HP and 1/2 HP, 115 Volt single phase 60 Hz. Pump discharge is 1-1/2" NPT. 2-pole float switch for minimum 10" diameter sumps.

- Ball Bearing Construction
- Adjustable Switch Setting
- High Performance
- Cast Iron Construction
- 10' Power Cord

FEATURES

EASY FIT

- 2-pole switch design allows for operation in sump diameters of 10" or more

RELIABLE AND TOUGH

- Rugged, oil-cooled motor provides continuous bearing lubrication and maximizes heat dissipation

EXTENDED SERVICE

- Lubricated ball bearings and shaft seal for longer service life

ELIMINATES FAILURES

- Shaded pole motor eliminates failure-prone switches and relays

MOTOR PROTECTION

- Long-life carbon/ceramic seal protects motor against water leakage

THERMAL OVERLOAD

- Heat sensor overload protection with automatic reset when motor cools to safe operating temperature

NO DRILLING REQUIRED

- Anti-airlock hole in base reduces added labor

EASY SERVICEABILITY

- Pump, intake screen, volute base, switch and power cord are serviceable

ORDERING INFORMATION

Catalog Number	HP	Volts	Phase/Cycles	Amps	Discharge Size	Switch Type	Cord Length	Approx. Wt. Lbs.
HP33	1/3	115	1/60	9.8	1-1/2"	2-pole	10'	27
HP50	1/2	115	1/60	12	1-1/2"	2-pole	10'	27

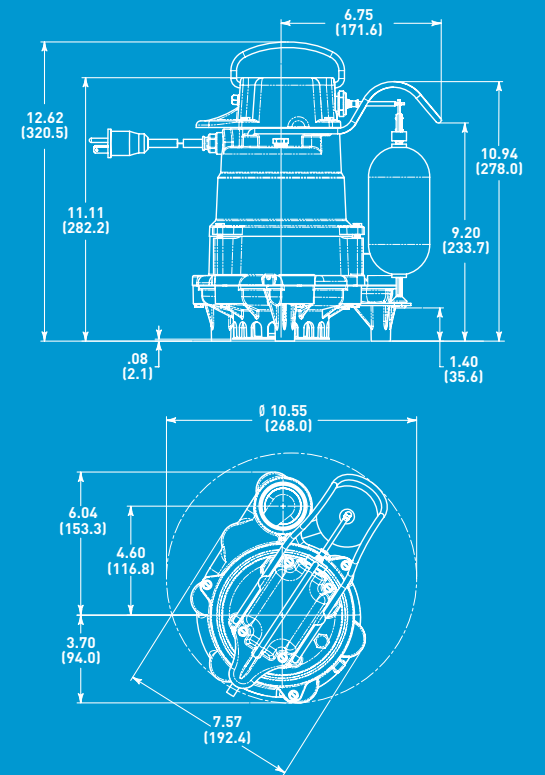

For more information about HYDROMATIC Plumbing Products contact your local HYDROMATIC Distributor, or our facilities in Delavan, WI and Canada.

**293 WRIGHT STREET
DELAVAN, WI 53115
PH: 888-957-8677
ORDERS FAX: 800-426-9446**

**269 TRILLIUM DRIVE, KITCHENER
ONTARIO, CANADA N2G 4W5
PH: 519-896-2163
ORDERS FAX: 519-896-6337**



Because we are continuously improving our products and services, Pentair reserves the right to change specifications without prior notice.

© 2012 Pentair Ltd. All Rights Reserved.

WWW.HYDROMATIC.COM

H10027 (12/13/12)