

HYDROMATIC® HP33/HP50 CAST IRON SUBMERSIBLE SUMP PUMP

Featuring a vortex impeller that provides solids-handling capability up to 1/2". Available in 1/3 HP, 115 volt single phase, 60 Hz and 1/2 HP, 115 volt single phase, 60 Hz. Pump discharge is 1-1/2" NPT. 2-pole float switch for minimum 10" diameter sumps. Also available in manual configuration.



HYDROMATIC® HP33/HP50 CAST IRON SUBMERSIBLE SUMP PUMP

Pump Characteristics

Pump/Motor Unit	Submersible	
Models	HP33	HP50
Motor	1/3 HP, shaded pole with thermal overload protection, 1550 RPM	1/2 HP, shaded pole with thermal overload protection, 1550 RPM
Electrical	115V, 1ø, 9.8A, 60 Hz	115V, 1ø, 12A, 60 Hz
Capacities	48 gpm (182 lpm)	62 gpm (235 lpm)
Heads	24' (7.3 m)	32' (9.8 m)
Approx. Weight	24 lbs.	26 lbs.
Operation	Automatic (manual also available) On: 9" (229 mm) Off: 4" (102 mm)	
Acceptable pH Range	6-9	
Liquids Handling	Drainage Effluent	
Continuous Liquid Temperature	130°F (54°C)	
Minimum Recommended Sump Diameter	10" (25.4 cm)	
Discharge Size	1-1/2" NPT (38.1 mm)	
Solids Handling	1/2" (12.7 mm)	
Power Cord	10' or 20', 16/3, SJTW-A, SJTW	

Materials of Construction

Handle	Stainless Steel
Lubricating Oil	Dielectric Oil
Motor Housing/Volute	Heavy Cast Iron
Volute Base	Fiberglass Reinforced Polypropylene
Shaft	Stainless Steel
Shaft Seal	Carbon and Ceramic
Impeller	Fiberglass-reinforced Noryl® with Threaded Brass Insert
Exterior Hardware	Stainless Steel
Maximum Liquid Temperature Limits	130°F (55°C)
Fasteners	Stainless Steel

Performance Data

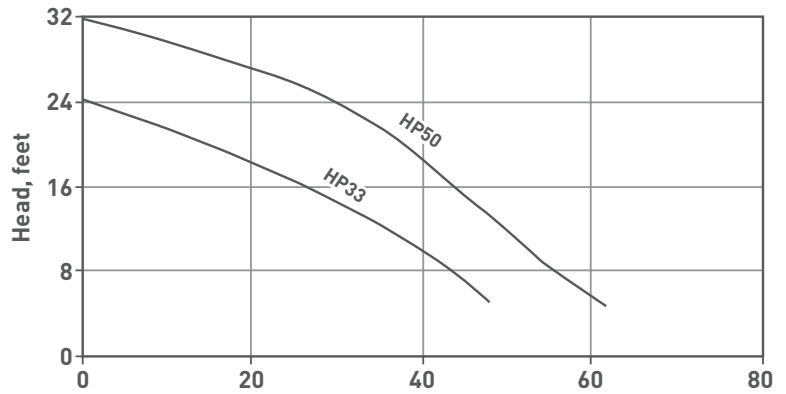

Dimensional Data

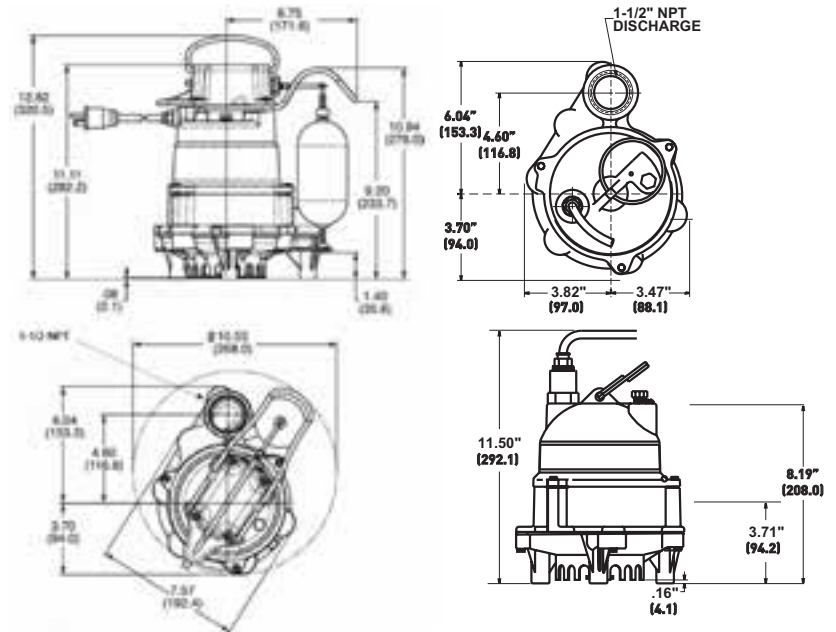

All dimensions in inches. Metric for international use. Component dimensions may vary $\pm 1/8$ inch. Dimensional data not for construction purpose unless certified. Dimensions and weights are approximate. On/Off level adjustable.



USA
293 WRIGHT STREET, DELAVAN, WI 53115 WWW.HYDROMATIC.COM
PH: 888-957-8677 ORDERS FAX: 800-426-9446

CANADA
269 TRILLIUM DRIVE, KITCHENER, ONTARIO, CANADA N2G 4W5
PH: 519-896-2163 ORDERS FAX: 519-896-6337

Because we are continuously improving our products and services, Pentair reserves the right to change specifications without prior notice.