

SUBMERSIBLE SUMP PUMPS

MS(P) SERIES

The Myers MS(P) Series Submersible Sump Pumps feature a zinc thermoplastic construction with a plastic volute and come in 1/3 HP and 1/2 HP models.

FEATURES

- ◆ Inexpensive yet versatile sump pump designed for light-duty drain water removal.
- ◆ Maintenance free operation.
- ◆ Wide-angle for 14" or larger sumps. Vertical switch for small 10" sumps.
- ◆ Dual ball-bearing motor and double lip seal provide durability and longer pump life.
- ◆ Durable PSC motor for years of service.
- ◆ Oil-filled motor for maximum heat dissipation, continuous bearing lubrication.
- ◆ Thermal overload protection with automatic reset.

SPECIFICATIONS

- ◆ **Capacities:** 53 GPM/63 GPM
- ◆ **Shut-Off Head:** 24' (7.3 m)
- ◆ **Tethered Operation:** When On = 14" (356mm); When Off = 5" (127 mm)
- ◆ **Vertical Operation:** When On = 7.5" (190.5 mm); When Off = 3" (76 mm)
- ◆ **Solids Handling:** 3/16" (4.78 mm)
- ◆ **Liquids Handling:** Drain water
- ◆ **Continuous Liquid Temp:** 77°F (25°C)
- ◆ **Motor:** 1/3 HP or 1/2 HP PSC Motor
- ◆ **Electrical Data:** 3000 RPM, 115V, 1Ø, 60Hz
FLA 1/3 HP = 3.9, 1/2 HP = 4.1
- ◆ **Acceptable pH Range:** 6-9
- ◆ **Shaft Seal:** Double lip
- ◆ **Motor Housing:** Zinc
- ◆ **Volute Case:** Thermoplastic
- ◆ **Power Cord:** 10' (25.4 m)
- ◆ **Discharge NPT:** 1-1/2"
- ◆ **Min. Sump Diameter for Float:** 14" (356 mm)
- ◆ **Vertical Min. Sump Diameter:** 10" (254 mm)



PUMP PERFORMANCE

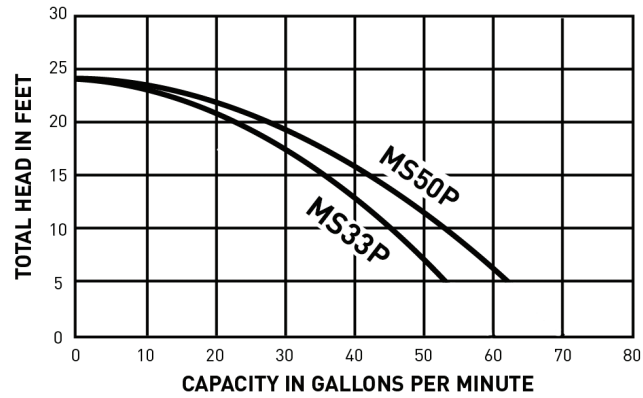

DIMENSIONS

MS33P AND MS50P SERIES

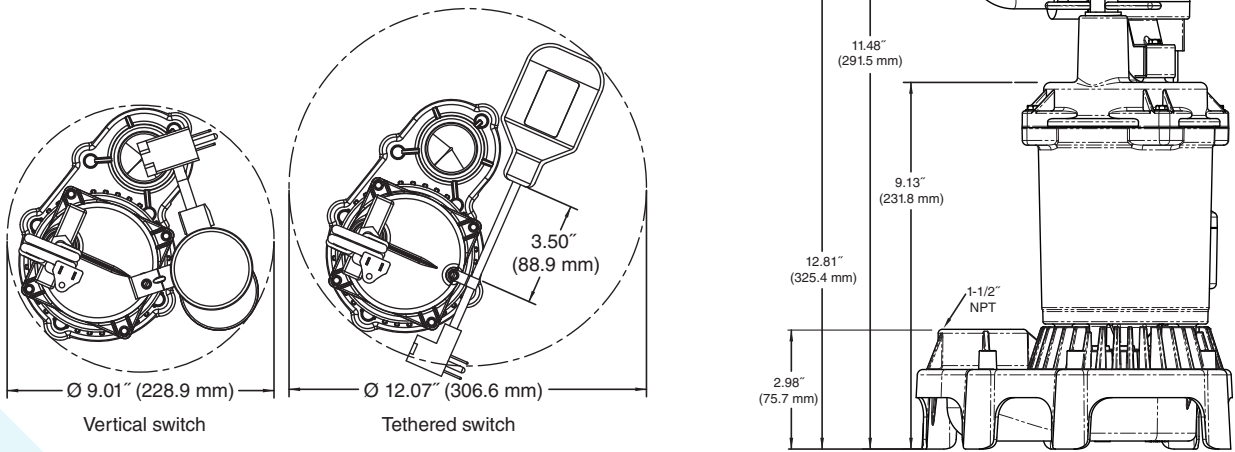

ORDERING INFORMATION

MODEL NUMBER	HP	MAX CAPACITY	MAX HEAD	DISCHARGE NPT	SOLIDS HANDLING	VOLTS	FULL LOAD AMPS	PHASE	CORD LENGTH	SWITCH
MS33PV10	1/3	53	24	1-1/2"	3/16"	115	3.9	1	10'	PV
MS33PT10	1/3	53	24	1-1/2"	3/16"	115	3.9	1	10'	PT
MS33PV20	1/3	53	24	1-1/2"	3/16"	115	3.9	1	20'	PV
MS50PV10	1/2	63	24	1-1/2"	3/16"	115	4.1	1	10'	PV
MS50PT20	1/2	63	24	1-1/2"	3/16"	115	4.1	1	20'	PT

All float switches are piggyback.



293 Wright St
Delavan, WI 53115
Ph: 888.987.8677
Fx: 800.426.9446

490 Pinebush Rd, Unit 4
Cambridge, Ontario N1T 0A5, Canada
Ph: 800.363.7867
Fx: 888.606.5484

pentair.com

All indicated Pentair trademarks and logos are property of Pentair. Third party registered and unregistered trademarks and logos are the property of their respective owners. Because we are continuously improving our products and services, Pentair reserves the right to change specifications without prior notice. Pentair is an equal opportunity employer.

©2023 Pentair. All Rights Reserved.

M1144ISSE (08-01-23)