

ELECTRONICS MANUAL



INSTALLATION, OPERATION, AND MAINTENANCE

pentair.com

TABLE OF CONTENTS

SECTION 1: SAFETY INSTRUCTIONS

SAFETY INSTRUCTIONS.....	4
--------------------------	---

SECTION 2: NOMENCLATURE

2.1 MOTORS.....	5
2.2 DRIVES.....	6
2.3 SUBMERSIBLE MOTOR CONTROLS.....	6

SECTION 3: INSTALLATION AND SETUP

3.1 GENERAL INSTALLATION GUIDELINES.....	7
3.2 PROPER GROUNDING.....	7
3.3 CORROSIVE WATER AND GROUND.....	7
3.4 CHECK VALVES.....	7
3.5 START-UP.....	8

SECTION 4: ELECTRICAL POWER

4.1 MIXING WIRE SIZE WITH EXISTING INSTALLATION....	9
4.2 WIRE SPLICING.....	9
4.3 THREE-PHASE STARTERS.....	10
4.4 CHECKING MOTOR ROTATION.....	11
4.5 THREE-PHASE CURRENT BALANCING.....	11
4.6 TRANSFORMER SIZING.....	12
4.7 USING A GENERATOR.....	13
4.8 SPECIAL APPLICATIONS.....	13

SECTION 5: XE SERIES 4" SUBMERSIBLE MOTORS

5.1 MOTOR INSPECTION.....	14
5.2 TESTING.....	14
5.3 STORAGE AND TRANSPORTATION.....	14
5.4 4" MOTOR SPECIFICATIONS.....	15
5.5 4" MOTOR DIMENSIONS.....	19
5.6 4" MOTOR FUSE SIZING.....	22
5.7 CABLE LENGTHS.....	24
5.8 4" MOTOR OVERLOAD PROTECTION.....	26
5.9 MOTOR COOLING.....	26
5.10 STARTING FREQUENCY.....	26

SECTION 6: PENTEK® 6" AND 8" SUBMERSIBLE MOTORS

6.1 MOTOR INSPECTION.....	27
6.2 TESTING.....	27
6.3 STORAGE AND DRAIN/FILL INSTRUCTIONS.....	27
6.4 MOTOR SPECIFICATIONS.....	30
6.5 MOTOR DIMENSIONS.....	31
6.6 MOTOR FUSE SIZING AND CABLE SELECTION.....	32
6.7 OVERLOAD PROTECTION.....	36
6.8 MOTOR COOLING.....	36
6.9 HEAD LOSS IN CASING.....	36
6.10 STARTING FREQUENCY.....	36
6.11 TROUBLESHOOTING.....	37

SECTION 7: HITACHI® 6" AND LARGER SUBMERSIBLE MOTORS

7.1 MOTOR INSPECTION.....	38
7.2 TESTING.....	39
7.3 STORAGE AND DRAIN FILL INSTRUCTIONS.....	39
7.4 MOTOR SPECIFICATIONS.....	40
7.5 MOTOR DIMENSIONS.....	43
7.6 MOTOR FUSE SIZING AND CABLE SELECTION.....	44
7.7 OVERLOAD PROTECTION.....	48
7.8 MOTOR COOLING.....	48
7.9 HEAD LOSS IN CASING.....	48
7.10 STARTING FREQUENCY.....	48
7.11 TROUBLESHOOTING.....	49

SECTION 8: PENTEK INTELLIDRIVE™ VARIABLE FREQUENCY DRIVES

8.1 GENERAL SAFETY.....	50
8.2 DESCRIPTION.....	51
8.3 INSTALLATION.....	53
8.4 INITIAL STARTUP.....	58
8.5 ADVANCED PROGRAMMING.....	59
8.6 I/O CONNECTIONS.....	64
8.7 WIRING SIZING, REPAIR PARTS, SPECIFICATIONS....	66
8.8 TROUBLESHOOTING.....	68

TABLE OF CONTENTS

SECTION 9: PENTEK INTELLIDRIVE™ XL PRODUCT SELECTION GUIDE

9.1 HOW TO SELECT YOUR DRIVE.....	70
9.2 NOMENCLATURE.....	71
9.3 PRODUCT DETAILS.....	72
9.4 VARIABLE FREQUENCY DRIVE ACCESSORIES.....	88

SECTION 10: SUBMERSIBLE MOTOR CONTROLS

10.1 HOW IT WORKS.....	89
10.2 SPECIFICATIONS.....	89
10.3 MOUNTING AND INSTALLATION.....	89
10.4 WIRING CONNECTIONS.....	90

SECTION 11: MOTOR PROTECTIVE DEVICES - 50/60 HZ

11.1 HOW THEY WORK.....	94
11.2 SPECIFICATIONS.....	94
11.3 MOUNTING AND INSTALLATION.....	95
11.4 WIRING CONNECTIONS.....	95

SECTION 12: TROUBLESHOOTING

12.1 PUMP AND MOTOR PROBLEM ANALYSIS.....	96
12.2 MOTOR TROUBLESHOOTING FLOW CHARTS.....	99
12.3 TESTING SUBMERSIBLE MOTOR INSULATION.....	103
12.4 SMART PUMP PROTECTOR TROUBLESHOOTING....	104
12.5 SUBMERSIBLE CONTROLS TROUBLESHOOTING...	105

SECTION 13: APPENDIX

13.1 INSTALLATION CHECKLIST.....	107
13.2 CHOOSING A PUMP SYSTEM.....	108
13.3 SIZING SUBMERSIBLE PUMP, MOTOR, AND TANKS. .	109
13.4 SELECTING THE CORRECT PUMPING EQUIPMENT...	110
13.5 SIZING TANKS.....	111
13.6 RECORD OF INSTALLATION.....	112

WARRANTY..... 114

SECTION 1: SAFETY INSTRUCTIONS

IMPORTANT SAFETY INSTRUCTIONS

SAVE THESE INSTRUCTIONS: This manual contains important instructions that should be followed during installation, operation, and maintenance of the product. Always refer to the equipment owner's manual for safety information relevant to that product.

 This is the safety alert symbol. When you see this symbol on your product or in this manual, look for one of the following signal words and be alert to the potential for personal injury!

 **DANGER** warns about hazards that will cause serious personal injury, death or major property damage if ignored.

 **WARNING** warns about hazards that can cause serious personal injury, death or major property damage if ignored.

 **CAUTION** indicates a hazard which, if not avoided, could result in minor or moderate injury.

The word **NOTE** indicates special instructions that are important but not related to hazards.

GENERAL SAFETY

- ♦ Carefully read and follow all safety instructions in this manual and on product.
- ♦ Keep safety labels in good condition.
- ♦ Replace missing or damaged safety labels.

CALIFORNIA PROPOSITION 65 WARNING

 **WARNING** This product and related accessories contain chemicals known to the State of California to cause cancer, birth defects or other reproductive harm.

ELECTRICAL SAFETY

 **WARNING RISK OF ELECTRIC SHOCK.** Can shock, burn or kill. All wiring should be done by a qualified electrician.

 **WARNING**



HAZARDOUS VOLTAGE. Can shock, burn, or cause death.

**ALL WORK
MUST BE DONE
BY A TRAINED
AND QUALIFIED
INSTALLER
OR SERVICE
TECHNICIAN.**

- ♦ Disconnect power before working on pump, motor or tank.
- ♦ Ground motor, controls, all metal pipe and accessories connected to the motor, to the power supply ground terminal. Ground wire must be at least as large as motor supply cables.
- ♦ Do not use the motor in a swimming area.

SECTION 2: NOMENCLATURE

2.1 MOTORS

TABLE 2-1: MOTOR NOMENCLATURE

Sample:

P43B0010A2-01 is a PENTEK 4" Stainless Steel Motor

1 HP, 60 Hz., 230 V, 1 Ph., Rev. 1

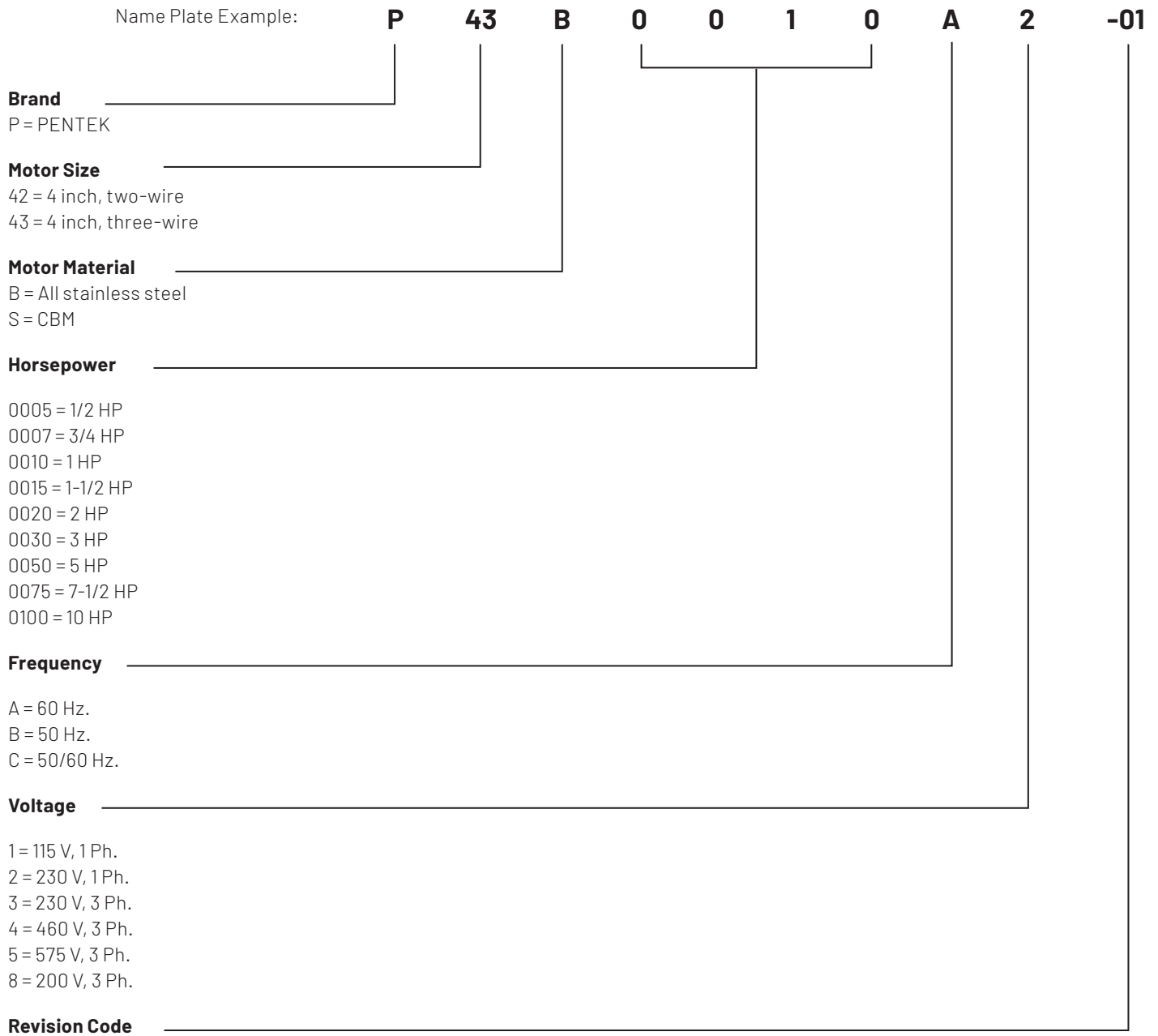

SECTION 2: NOMENCLATURE

2.2 DRIVES

PID10-01 VARIABLE FREQUENCY DRIVE NOMENCLATURE

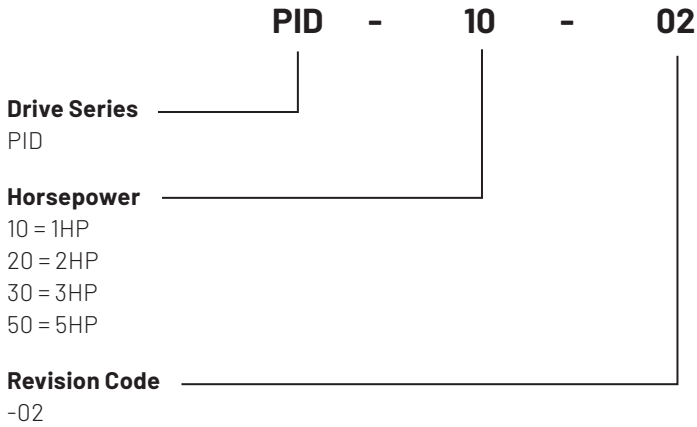

2.3 SUBMERSIBLE MOTOR CONTROLS

The chart below shows the naming for a Submersible Motor Control, standard box, capacitor run, 5 HP, 230 volt single phase drive.

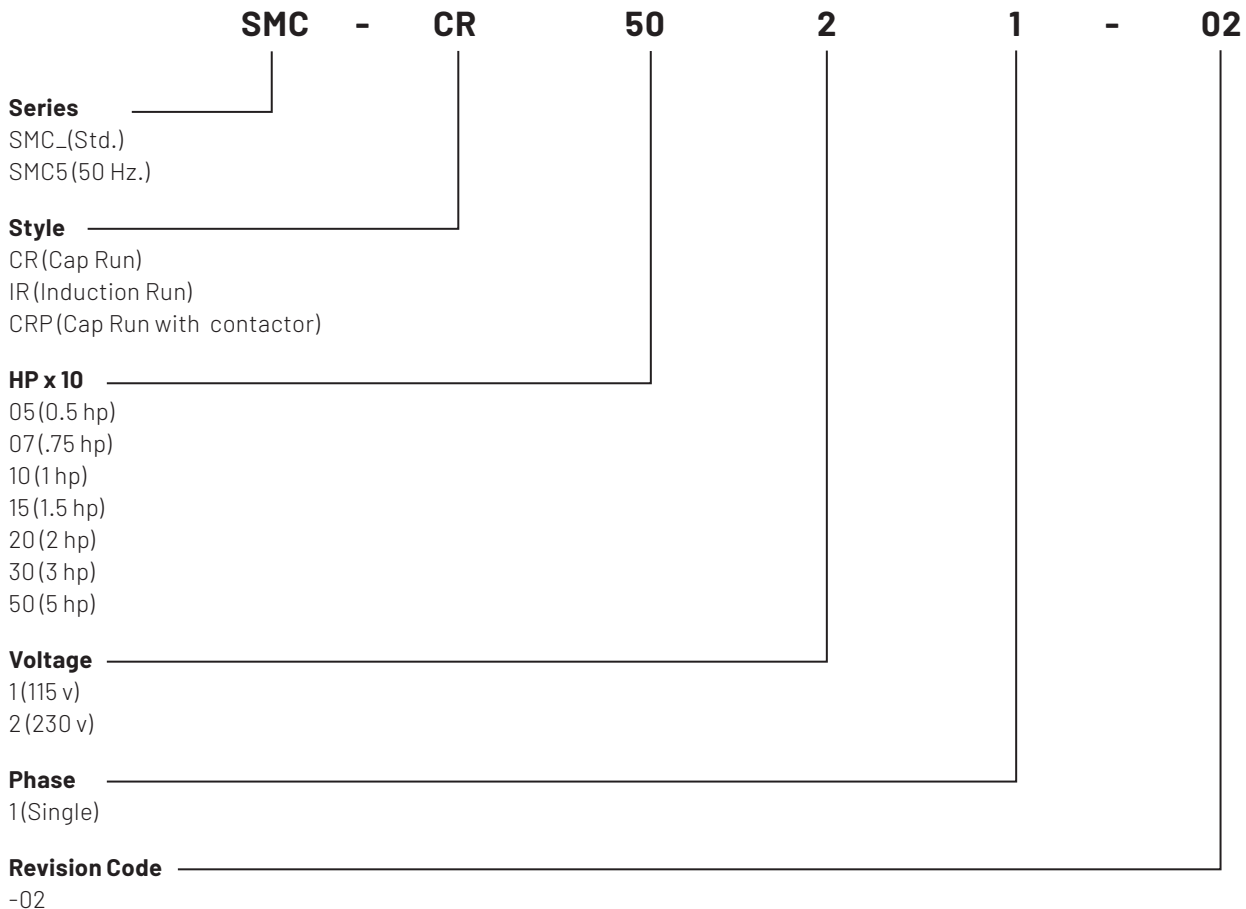

SECTION 3: INSTALLATION AND SETUP

3.1 GENERAL INSTALLATION GUIDELINES

In order to avoid abrasion to the power and control cables, pad the top of the well casing where the cable will pass over it. A rubber pad is recommended. Use a cable reel for cable control.

- ◆ The unit must always be easy to rotate in the hoisting gear.
- ◆ Lay power and control cables out straight on the ground (no loops) before installation. Guide cables during lowering so that they are not stretched or squeezed while pump is being installed. Make sure that cable insulation is not nicked or damaged before or during installation. Never use the electrical cables to move the motor/pump.
- ◆ The pump and motor are heavy. Make sure that all connections are secure and that the hoisting gear is adequate to do the job before starting to lift pump. **DO NOT** stand under the unit. **DO NOT** allow extra people into the area while hoisting the unit.
- ◆ If motor or pump/motor unit are attached to a supporting girder, do not remove girder until unit is vertical.
- ◆ Install pump at least 10' (3m) below the lowest water level during pumping, but at least 6' (2m) above the bottom of the well.
- ◆ 6" motors can be operated in vertical or horizontal positions when lead wire is at 12:00 position facing motor flange.
- ◆ 4" motors can be operated in vertical or horizontal positions. Note that the thrust bearing will have shorter life in a non-vertical application. In such an installation, keep frequency of starts to less than 10 per day.

3.2 PROPER GROUNDING

⚠ WARNING HAZARDOUS VOLTAGE. Can shock, burn or cause death. Installation or service to electrical equipment should only be done by qualified electrician.

- ◆ Control panels must be connected to supply ground. Proper grounding serves two main purposes:
 1. It provides a path to ground in case of a ground-fault. Otherwise the current would present a shock or electrocution hazard.
 2. It protects equipment from electrical surges.
- ◆ Use wire the same size as, or larger than motor's current-carrying wires. Consult Tables in the motor section.
- ◆ Installations must comply with the National Electric Code as well as state and local codes.
- ◆ All systems must have lightning (surge) protection with a secure connection to ground.

- ◆ An above ground lightning (surge) protection must be grounded metal-to-metal and extend all the way to the water bearing layer to be effective. Do not ground the lightning (surge) protection to the supply ground or to a ground rod as this will provide little or no surge protection to the unit.
- ◆ All motors are internally grounded and requires a 3 or 4-wire drop cable.

3.3 CORROSIVE WATER AND GROUND

Some waters are corrosive, and can eventually corrode the ground wire. If the installation uses a metal well casing, any ground current will flow through it. In the case of plastic piping and casing, the water column would carry the current in a ground fault situation.

To prevent this, route the motor ground wire and the motor power leads through a GFCI with a 10 mA set point. In this way, the GFCI will trip when a ground fault has occurred AND the motor ground wire is no longer functional.

3.4 CHECK VALVES

Check valve installation is necessary for proper pump operation. The pump should use only spring type or gravity-poppet check valves. Swing type valves can cause water hammer problems.

- ◆ Do not use drain-back style check valves (drilled).
- ◆ Check valves serve the following purposes:
 - Maintain Pressure: Without a check valve, the pump has to start each cycle at zero head, and fill the drop pipe. This creates upthrust in the motor, and would eventually damage both the pump and motor.
 - Prevent Water Hammer: If two check valves are used, and the lower one leaks, then a partial vacuum forms in the pipe. When the pump next starts, the flow fills the void area quickly, and creates a shock wave that can break piping and damage the pump. If you get water hammer on pump start, this may be the cause.
 - Prevent Back-Spin: Without a functioning check valve, upon shutoff, the water drains back through the pump, and cause it to rotate backwards. This can create excessive wear on the thrust bearing, and if the pump restarts as water is flowing down the pipe, it will put an excessive load on the system.

SECTION 3: INSTALLATION AND SETUP

3.5 START-UP

To avoid sand-locking pump, follow procedure below when starting pump for the first time. **NEVER** start a pump with discharge completely open unless you have done the following procedure first:

1. Connect a pipe elbow, a short length of pipe, and a gate valve to pump discharge at well head.
2. Make sure that controls will not be subjected to extreme heat or excess moisture.
3. Make sure power is OFF. DO NOT START PUMP YET.
4. Set gate valve on discharge 1/3 open. Start pump.
5. Keep gate valve at this setting while water pumps out on ground. Let it run until water is clear of sand or silt. To check solids in water, fill a glass from pump and let solids settle out.
6. When water is completely clear at 1/3 setting, open gate valve to approximately 2/3 open and repeat process.
7. When water is completely clear at 2/3 setting, open gate valve completely and run pump until water is completely clear.
8. Do not stop the pump until the water is clear. Otherwise sand will accumulate in the pump stages which may bind or freeze the pump.
9. Remove gate valve and make permanent installation.

The motor may draw higher than normal current while the riser pipe is filling. After the riser pipe is full, the amp draw should drop back to less than the allowed current given on the motor nameplate.

When pump is in service, the amp draw must be approximately equal to or lower than the service factor amps given on the motor nameplate. If not, recheck entire installation and electrical hook-up to find out why amp draw is higher than normal.

MOTOR TORQUE

The motor exerts a strong torque force on the downpipe and any other supporting structures when it starts. This torque is usually in the direction that unscrews right-hand threads, including the motor's reaction movement, which is clockwise as seen from above.

All pipe and pump joints must be tightened to safely handle the starting torque. Tighten all threaded joints to a minimum of 10 ft.-lb per horsepower. i.e. 20 HP = 200 ft.-lb; 50 HP = 500 ft.-lb.

Tack welding or strap welding may be required with higher horsepower pumps.

SECTION 4: ELECTRICAL POWER

4.1 MIXING WIRE SIZE WITH EXISTING INSTALLATION

USING TWO DIFFERENT CABLE SIZES

Conditions may make it desirable to use more than one size cable, such as replacing a pump in an existing installation.

Example (Figure 4-1): Installing a pump with a 4", 5 HP, 230 volt, single phase motor, with the motor setting at 370' (112.8 m) down the well and with 160' (48.8 m) of #8 cable buried between the service entrance and the well head.

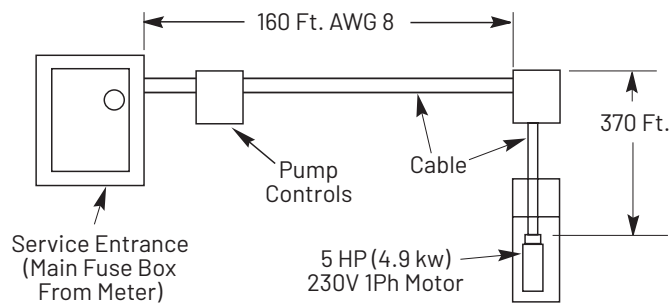

Figure 4-1: Mixing Wire Sizes Example

In order to avoid replacing the buried cable, calculate the required cable size in the well as follows:

1. According to Table 5-9, a total of 326' (112.8 m) of #8 cable is the maximum length cable to power a 5 HP motor. The percent of this total that has been used by the 160' (48.8 m) of cable in the buried run is: $160' / 326' = .49$ or 49%.
2. With 49% of the allowable cable already used, 51% of the total length is left for use in the well. To avoid running a cable of too small a gauge and lowering the voltage to the motor, we have to find a cable size large enough so that 370' (112.8 m) is less than 51% of the total length allowed for that size.
3. That calculation is: $370 \div 51\% = 726$ feet.
4. From Table 5-9 we find that the total allowable length for #4 cable is 809' (246.6 m).
5. This is longer than needed. Therefore, #4 cable can be used for the 370' (112.8 m) of cable in the well.
6. Any combination of sizes can be used, provided that the total percentage of the length of the two sizes of cable is not less than 100% of the allowed lengths.

4.2 WIRE SPLICING

Splice wire to motor leads. Use only copper wire for connections to pump motor and control box.

1. Taped splice (for larger wire sizes):
 - A. Stagger lead and wire length so that 2nd lead is 2" (50mm) longer than 1st lead and 3rd lead is 2" (50mm) longer than second.
 - B. Cut off power supply wire ends. Match colors and lengths of wires to colors and lengths of motor leads.
 - C. Trim insulation back 1/2" (13mm) from supply wire and motor lead ends (Figure 4-2).

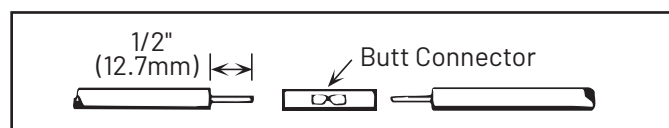

Figure 4-2: Insert Wires

- D. Insert motor lead ends and supply wire ends into butt connectors. Match wire colors between supply wires and motor leads.
- E. Using crimping pliers, indent butt connector lugs to attach wires (Figure 4-3).

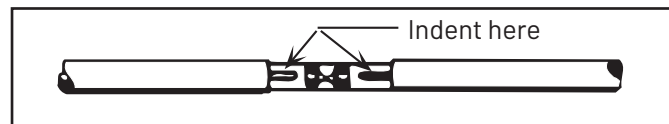

Figure 4-3: Indent Connectors

- F. Cut Scotchfil™ electrical insulation putty into 3 equal parts and form tightly around butt connectors. Be sure Scotchfil overlaps insulated part of wire.
- G. Using #33 Scotch® tape, wrap each joint tightly: cover wire for about 1-1/2" (38mm) on each side of joint. Make four passes with the tape. When finished you should have four layers of tape tightly wrapped around the wire. Press edges of tape firmly down against the wire (Figure 4-4).

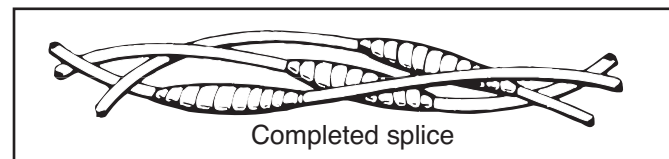

Figure 4-4: Wrap Splices

SECTION 4: ELECTRICAL POWER

Since tightly wound tape is the only means of keeping water out of splice, efficiency of splice depends on care used in wrapping tape.

For wire sizes larger than No. 8 (7mm²), use soldered joint rather than Scotchfil putty (Figure 4-5).



Figure 4-5: Twist Wires

2. Heat shrink splice. For wire sizes #14, 12, and 10 AWG (2, 3, and 5mm²), heat shrink splice as follows:
 - A. Remove 3/8" (9.5mm) insulation from ends of motor leads and power supply wires.
 - B. Put plastic heat shrink tubing over motor leads between power supply and motor.
 - C. Match wire colors and lengths between power supply and motor.
 - D. Insert supply wire and lead ends into butt connector and crimp. Match wire colors between power supply and motor. Pull leads to check connections.
 - E. Center tubing over butt connector and apply heat evenly with a torch. A match or lighter does not supply enough heat (Figure 4-6). Keep torch moving. Too much concentrated heat may damage tubing.

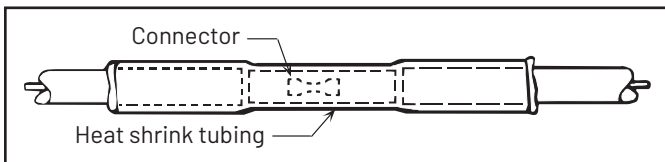

Figure 4-6: Heat-Shrink Tubing Applied

4.3 THREE-PHASE STARTERS

Starters are used to start the motor by engaging contacts that will energize each line simultaneously. The contacts are closed when the coil is energized.

Figures 4-7 through 4-9 show three types of starters used on the motors. The control device in the secondary circuit is typically a pressure switch. Other control could be provided by level control, timers or manual switches.

LINE VOLTAGE CONTROL

This commonly used control has a coil energized by line voltage. The coil voltage matches the line voltage.

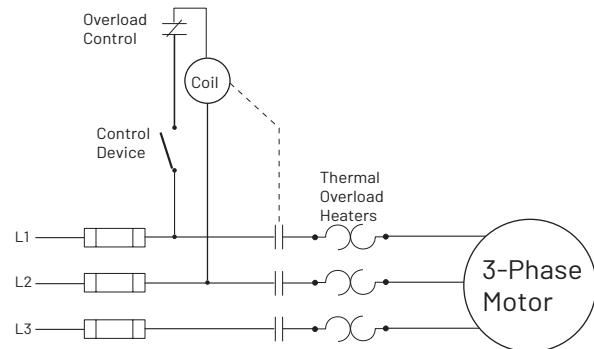

Figure 4-7: Line Voltage Control

LOW VOLTAGE CONTROL

This starter arrangement uses a transformer to allow the coil to be energized by a lower voltage. The secondary circuit must be fused, and the coil sized for the secondary voltage.

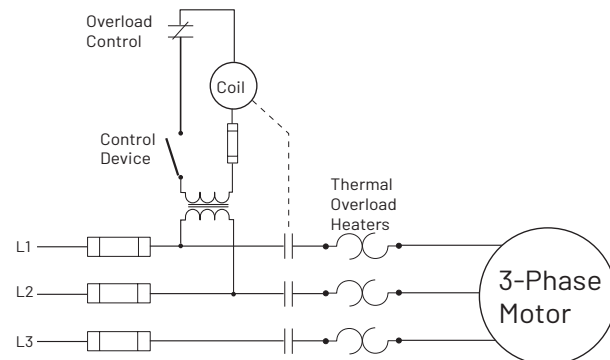

Figure 4-8: Low Voltage Control

SEPARATE VOLTAGE CONTROL

This arrangement uses power from a separate source to energize the coil.

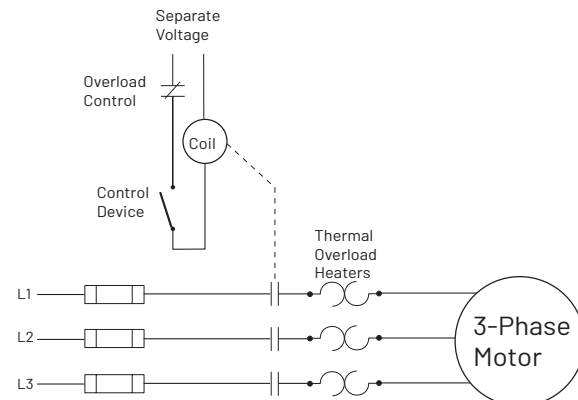

Figure 4-9: Separate Voltage Control

SECTION 4: ELECTRICAL POWER

4.4 CHECKING MOTOR ROTATION

Check rotation before the pump is installed.

1. During testing or checking rotation (such as “bumping” or “inching”) the number of “starts” should be limited to 3 and total run time of less than 15 seconds.

Bumping must be done while motor is in horizontal position and followed by a full 15 minute cooling-off period before any additional starts are attempted.

NEVER continuously operate a pump with the discharge valve completely closed (dead head). This can overload the motor due to lack of cooling, or destroy the pump and will void the warranty.

2. Energize the motor briefly, and observe the direction of rotation. It should be counter-clockwise when viewed from the pump (shaft) end.

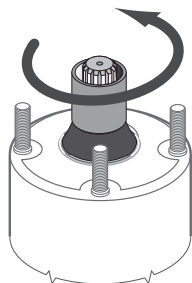

Figure 4-10: Motor Rotation

To check rotation after the pump is installed.

1. After energizing the motor, check the flow and pressure of the pump to make sure that the motor is rotating in the correct direction.

To correct a wrong rotation, switch any two of the three cable connections (three-phase motor only). The setting that gives the most flow and pressure is correct.

2. A cooling-off period of 15 minutes is required between starts.
3. Throughout installation, record input voltage, current, and insulation resistance values and used for preventive maintenance.

4.5 THREE-PHASE CURRENT BALANCING

CURRENT UNBALANCE TEST

Before checking for current unbalance, the pump must be started, and rotation direction determined.

Determine current unbalance by measuring current in each power lead. Measure current for all three possible hookups (Figure 4-11). Use Table 4-1: Electrical Current Unbalance Example and the Installation Checklist worksheet in Section 13 to calculate current unbalance on a three phase supply system and retain for future reference.

Current unbalance between leads should not exceed 5%. If unbalance cannot be corrected by rolling the leads, locate the source of the unbalance.

Below is an example of current readings at maximum pump loads on each leg of a three wire hookup. Make calculations for all three possible hookups.

- A. For each hookup, add the readings for the three legs.
- B. Divide each total by three to get average amps.
- C. For each hookup, find current value farthest from average. Calculate the greatest current difference from the average.
- D. Divide this difference by the average and multiply by 100 to obtain the percentage of unbalance.
- E. Use smallest percentage unbalance, in this case Arrangement 2 (Table 4-1).

USE THE CURRENT-BALANCE WORKSHEET LOCATED IN THE INSTALLATION RECORD

After trying all three lead hookups, if the reading furthest from average continues to show on the same power lead, most of the unbalance is coming from the power source. Call the power company.

If the reading furthest from average changes leads as the hookup changes (that is, stays with a particular motor lead), most of the unbalance is on the motor side of the starter. This could be caused by a damaged cable, leaking splice, poor connection, or faulty motor winding.

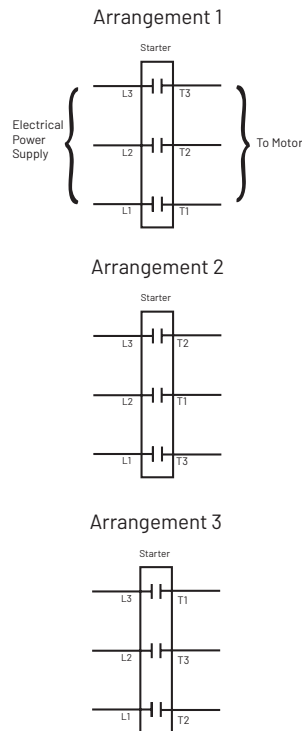

Figure 4-11: Example of Three-Phase Current Unbalance

SECTION 4: ELECTRICAL POWER

Use the following worksheet to calculate current unbalance for our installation.

TABLE 4-1: ELECTRICAL CURRENT UNBALANCE EXAMPLE

EXAMPLE	ARRANGEMENT 1 AMPS	ARRANGEMENT 2 AMPS	ARRANGEMENT 3 AMPS
	L1-T1=17 L2-T2=15.3 L3-T3=17.7	L1-T3=16.7 L2-T1=16.3 L3-T2=17	L1-T2=16.7 L2-T3=16 L3-T1=17.3
TOTAL AMPS	50	50	50
AVERAGE AMPS	$50 \div 3 = 16.7$	$50 \div 3 = 16.7$	$50 \div 3 = 16.7$
FROM AVERAGE AMPS			
DEVIATION L1	0.3	0.0	0.0
DEVIATION L2	1.4	0.4	0.7
DEVIATION L3	1.0	0.3	0.6
% CURRENT UNBALANCE LARGEST DEVIATION	$1.4 \div 16.7$	$0.4 \div 16.7$	$0.7 \div 16.7$
% UNBALANCE +	8.4%	2.4%	4.2%

4.6 TRANSFORMER SIZING

A full three-phase power supply is recommended for all three-phase motors and may consist of three individual transformers or one three-phase transformer. "Open" delta or wye connections, which use only two transformers can be used, but are more likely to cause unbalanced current problems. Transformer ratings should be no smaller than listed in Table 4-2 for supply power to the motor alone.

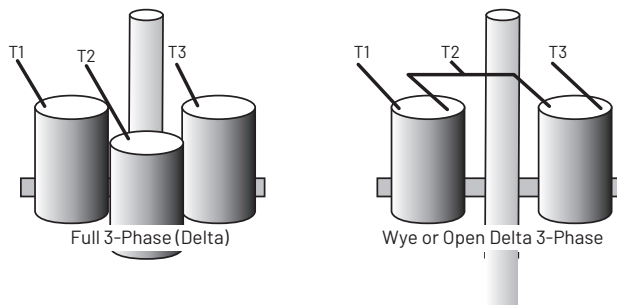

Figure 4-12: Three Phase Power

Transformers are rated by KVA capacity. This must be high enough capacity for the motor being installed. If the transformer capacity is too small, the motor will receive reduced voltage and may be damaged.

Any other loads in the system would be in addition to the motor alone.

In Table 4-2, note that the open delta configuration can only use 87% of the rated power of the two transformers.

TABLE 4-2: TRANSFORMER CAPACITY

HP	KW	KVA RATING (SMALLEST) FOR EACH TRANSFORMER		
		REQUIRED KVA	OPEN WYE OR D 2 TRANSFORMERS	WYE OR D 3 TRANSFORMERS
1/2	0.37	1.5	1.0	0.5
3/4	0.55	1.5	1.0	0.5
1	0.75	2.0	1.5	0.75
1-1/2	1.1	3.0	2.0	1.0
2	1.5	4.0	2.0	1.5
3	2.2	5.0	3.0	2.0
5	3.7	7.5	5.0	3.0
7.5	5.5	10.0	7.5	5.0
10	7.5	15.0	10.0	5.0
15	11.0	20.0	15.0	7.5
20	15.0	25.0	15.0	10.0
25	18.5	30.0	20.0	10.0
30	22.0	40.0	25.0	15.0
40	30.0	50.0	30.0	20.0
50	37.0	60.0	35.0	20.0
60	45.0	75.0	40.0	25.0

SECTION 4: ELECTRICAL POWER

4.7 USING A GENERATOR

SELECTING A GENERATOR

Select a generator that can supply at least 65% of rated voltage upon start-up of the motor.

The chart shows ratings of generators, both externally and internally regulated. This chart is somewhat conservative. Consult the generator manufacturer if you are uncertain.

TABLE 4-3: RATINGS OF GENERATORS

MOTOR	EXTERNALLY REGULATED		INTERNALLY REGULATED	
	kW	KVA	kW	KVA
1/2	2.0	2.5	1.5	1.9
3/4	3.0	3.8	2.0	2.5
1	4.0	5.0	2.5	3.1
1-1/2	5.0	6.3	3.0	3.8
2	7.5	9.4	4.0	5.0
3	10.0	12.5	5.0	6.25
5	15.0	18.8	7.5	9.4
7-1/2	20.0	25.0	10.0	12.5
10	30.0	37.5	15.0	18.8
15	40.0	50.0	20.0	25.0
20	60.0	75.0	25.0	31.0
25	75.0	94.0	30.0	37.5
30	100.0	125.0	40.0	50.0
40	100.0	125.0	50.0	62.5
50	150.0	188.0	60.0	75.0
60	175.0	220.0	75.0	94.0

FREQUENCY

It is highly important that the generator maintain constant frequency (Hz), since the motor's speed depends upon frequency.

A drop of just 1 to 2 Hz can noticeably lower pump performance. An increase of 1 to 2 Hz can cause overload conditions.

VOLTAGE REGULATION

There is a significant difference in the performance of internally and externally regulated generators.

An external regulator senses output voltage dips and triggers an increase in the voltage output of the generator.

An internal regulator, senses current and responds to increased current by supplying more voltage.

GENERATOR OPERATION

Start the generator before starting the pump motor.

The pump motor must be stopped before turning off the generator.

If the generator runs out of fuel and the pump is still connected, it will put excess strain on the thrust bearings as the generator slows.

⚠ WARNING RISK OF ELECTROCUTION. Use transfer switches when the generator is used as a backup to the power grid. Contact your power company or generator manufacturer for proper use of standby or backup generators.

4.8 SPECIAL APPLICATIONS

USING PHASE CONVERTERS

Phase converters allow three-phase motors to operate from one-phase supply. Various styles of phase converters are available. Many converters do not supply a properly balanced voltage, and using these will void the motor's warranty unless approval is obtained first.

GUIDELINES FOR PHASE CONVERTERS

- ◆ Current unbalance must be less than 5%.
- ◆ Converter to be sized to service factor capacity.
- ◆ Maintain motor cooling with a cooling flow of at least 3' per second.
- ◆ Fuses and circuit breakers must be time-delay type.

MOTOR STARTING WITH REDUCED VOLTAGE

Starting a motor with full voltage will bring it to full speed in less than 1/2 second. This can:

- ◆ Spike the load current, causing brief voltage dips in other equipment.
- ◆ Over-stress pump and piping components because of high torque.
- ◆ Cause water hammer.

MOTOR STARTERS (THREE-PHASE ONLY)

Various types of motor starters are available. Autotransformers are recommended because of reduced current draw.

When motor starters are used, they should supply a minimum of 55% of rated voltage for adequate starting torque.

SECTION 5: XE SERIES 4" SUBMERSIBLE MOTORS

5.1 MOTOR INSPECTION

Check the motor for damage in shipping. Before installation, check the following.

- ◆ Check over all tools, especially the hoisting gear, for wear or damage before hoisting unit.
- ◆ Inspect the motor cable for any nicks or cuts.
- ◆ Verify that motor nameplate data matches registration card information exactly.
- ◆ Verify that motor nameplate voltage is correct for available power supply voltage. Voltage must not vary more than +/-10% from nameplate rated voltage.
- ◆ Verify that the well diameter is large enough to accommodate the motor/pump unit all the way to the pump setting depth.
- ◆ For installations with tight well casings, make sure that riser pipe flanges are recessed to protect the power and control cables from abrasion and squeezing during installation.
- ◆ **⚠ WARNING HEAVY OBJECT.** Lifting equipment must be capable of lifting motor and attached equipment.
- ◆ If the total length of the pump motor unit (without any riser pipe) exceeds 10'(3m), the unit must be supported with a girder while hoisting. Do not remove supporting girder until unit is standing vertically in the hoist. Check for damage.

5.2 TESTING

INSULATION RESISTANCE

To check for insulation resistance:

1. Disconnect power to the motor for this test.
2. Connect an Ohm meter (resistance in Ω) between the power leads and the motor ground or well casing.

20K Ω Damaged motor, possible result of lightning strike.

500K Ω Typical of older installed motor in well.

2 M Ω Newly installed motor.

10 M Ω Used motor, measured outside of well.

20 M Ω New motor without cable.

5.3 STORAGE AND TRANSPORTATION

The motors are filled with a non-toxic Propylene Glycol and water solution to prevent damage from freezing temperatures. The solution will prevent damage from freezing temperatures to -40°F (-40°C). Motors should be stored in areas that do not go below this temperature. The solution will become slushy between 0°F (-17°C) and -40°F (-40°C) but no damage occurs. If this occurs, allow the motor to sit in the well for several minutes before operating.

- ◆ Storage site should be clean, well vented, and cool.
- ◆ Keep humidity at the storage site as low as possible.
- ◆ Protect motor and cables from direct sunlight.
- ◆ Protect power supply cables and control cables from moisture by taping the cable ends with electrician's tape.
- ◆ Do not kink power supply or control cables.
- ◆ Take care when moving unit (packed or unpacked) with crane or hoisting gear not to knock it against walls, steel structure, floors, etc. Do not drop motor.
- ◆ Do not lift motor or motor/pump unit by power supply or control cables.

SECTION 5: XE SERIES 4" SUBMERSIBLE MOTORS

5.4 4" MOTOR SPECIFICATIONS

TABLE 5-1: SINGLE PHASE MOTOR ELECTRICAL PARAMETERS

MOTOR TYPE	PENTEK PART NUMBER	FULL LOAD			SERVICE FACTOR		
		AMPS (B OR Y/B/R)	Y ONLY	WATTS	AMPS (B OR Y/B/R)	Y ONLY	WATTS
PSC 2-Wire	P42B0005A1-01	8.1		890	10.2		1110
	P42B0005A2-01	4.3		845	4.8		1035
	P42B0007A2-01	5.0		1100	6.4		1375
	P42B0010A2-01	6.7		1450	8.2		1770
	P42B0015A2-01	9.1		1950	10.5		2300
	P42B0005A1	7.4		845	9.5		1088
	P42B0005A2	3.7		834	4.7		1073
	P42B0007A2	5.0		1130	6.4		1459
	P42B0010A2	7.9		1817	9.1		2093
	P42B0015A2	9.2		2116	11.0		2530
	P42B0005A1-02	8.4		880	10.0		1090
	P42B0005A2-02	4.2		870	5.1		1050
	P42B0007A2-02	4.8		1040	6.1		1325
	P42B0010A2-02	7.0		1570	8.0		1820
	P42B0015A2-02	9.0		1980	10.6		2350
CSIR 3-Wire	P43B0005A1-01	9.8/9.8/0	9.8	670	11.6/11.6/0	11.6	980
	P43B0005A2-01	5.7/5.7/0	5.7	735	6.3/6.3/0	6.3	1035
	P43B0007A2-01	6.7/6.7/0	6.7	940	7.9/7.9/0	7.9	1335
	P43B0010A2-01	8.5/8.5/0	8.5	1175	9.5/9.5/0	9.5	1590
	P43B0005A1	11.0/11.0/0	11.0	733	12.6/12.6/0	12.6	1021
	P43B0005A2	5.5/5.5/0	5.5	745	6.3/6.3/0	6.3	1033
	P43B0007A2	7.2/7.2/0	7.2	1014	8.3/8.3/0	8.3	1381
	P43B0010A2	8.4/8.4/0	8.4	1267	9.7/9.7/0	9.7	1672
	P43B0005A1-02	9.0/9.0/0	9.0	690	11.0/11.0/0	11.0	1020
	P43B0005A2-02	4.8/4.8/0	4.8	720	5.6/5.6/0	5.6	1055
	P43B0007A2-02	6.2/6.2/0	6.2	980	7.4/7.4/0	7.4	1390
	P43B0010A2-02	7.4/7.4/0	7.4	1235	9.0/9.0/0	9.0	1670
CSCR 3-Wire	P43B0005A2-01	4.4/4.3/1.9	4.4	715	5.0/4.5/1.9	5.0	950
	P43B0007A2-01	4.6/4.6/2.6	4.6	920	6.1/5.1/2.6	6.1	1235
	P43B0010A2-01	6.2/6.0/3.6	6.2	1165	7.4/6.3/3.3	7.4	1490
	P43B0015A2-01	9.2/8.7/1.2	9.2	1660	11.0/9.9/1.2	11.0	2110
	P43B0005A2	4.1/4.1/2.2	4.1	720	4.9/4.4/2.1	4.9	955
	P43B0007A2	5.1/5.0/3.2	5.1	1000	6.3/5.6/3.3	6.3	1300
	P43B0010A2	6.1/5.7/3.3	6.1	1205	7.2/6.3/3.3	7.2	1530
	P43B0015A2	9.7/9.5/1.4	9.7	1693	11.1/11.0/1.3	11.1	2187
	P43B0020A2	9.9/9.1/2.6	9.9	2170	12.2/11.7/2.6	12.2	2660
	P43B0030A2	14.3/12.0/5.7	14.3	3170	16.5/13.9/5.6	16.5	3620
	P43B0050A2	24/19.1/10.2	24	5300	27.0/22.0/10.0	27.0	6030
	P43B0005A2-02	3.7/3.6/1.7	3.7	690	4.6/4.4/1.6	4.6	950
	P43B0007A2-02	4.9/4.8/2.8	4.9	1000	6.1/5.5/2.6	6.1	1300
	P43B0010A2-02	5.7/5.2/3.0	5.7	1185	7.1/5.9/2.9	7.1	1495
P43B0015A2-02	8.9/8.5/1.3	8.9	1685	10.7/10.4/1.2	10.7	2170	

SECTION 5: XE SERIES 4" SUBMERSIBLE MOTORS

TABLE 5-2: THREE PHASE 4" MOTOR ELECTRICAL PARAMETERS

PENTEK PART NUMBER	RATING				SERVICE FACTOR	FULL LOAD		MAXIMUM LOAD (SF LOAD)	
	HP	KW	VOLTS	HZ		AMPS	WATTS	AMPS	WATTS
P43B0005A8	1/2	0.37	200	60	1.6	2.9	600	3.5	860
P43B0005A3			230			2.4	575	3.0	860
P43B0005A4			460			1.3	620	1.5	865
P43B0007A8	3/4	0.55	200		1.5	3.9	820	4.7	1150
P43B0007A3			230			3.3	805	4.0	1160
P43B0007A4			460			1.7	825	2.0	1140
P43B0010A8	1	0.75	200		1.4	4.8	1120	5.7	1470
P43B0010A3			230			4.1	1070	4.9	1440
P43B0010A4			460			2.2	1140	2.5	1460
P43B0015A8	1-1/2	1.1	200		1.3	6.6	1650	7.6	1950
P43B0015A3			230			5.8	1550	6.6	1950
P43B0015A4			460			3.0	1540	3.4	1960
P43B0015A5			575			2.3	1540	2.6	1970
P43B0020A8	2	1.5	200		1.25	8.0	1960	9.3	2455
P43B0020A3			230			6.7	1965	8.0	2465
P43B0020A4			460	3.6		1960	4.1	2440	
P43B0020A5			575	2.7		1610	3.3	2400	
P43B0030A8	3	2.2	200	1.15	10.9	2890	12.0	3290	
P43B0030A3			230		9.2	2880	10.1	3280	
P43B0030A4			460		4.8	2920	5.3	3320	
P43B0030A5			575		3.7	2850	4.1	3240	
P43B0050A8	5	3.7	200	1.15	18.3	4850	20.2	5515	
P43B0050A3			230		15.7	4925	17.5	5650	
P43B0050A4			460		7.6	4810	8.5	5530	
P43B0050A5			575		7.0	5080	7.6	5750	
P43B0075A8	7-1/2	5.5	200	1.15	27.0	7600	30.0	8800	
P43B0075A3			230		24.0	7480	26.4	8570	
P43B0075A4			460		12.2	7400	13.5	8560	
P43B0075A5			575		9.1	7260	10.0	8310	
P43B0100A4	10	7.5	460		15.6	9600	17.2	11000	

SECTION 5: XE SERIES 4" SUBMERSIBLE MOTORS

TABLE 5-3: SINGLE PHASE MOTOR SPECIFICATIONS

MOTOR TYPE	PENTEK PART NUMBER	WINDING		EFFICIENCY %		POWER FACTOR %		LOCKED ROTOR AMPS	KVA CODE
		MAIN RESISTANCE*	START RESISTANCE	FL	SF	FL	SF		
PSC 2-Wire	P42B0005A1-01	1.4 - 2.0		42.0	54.0	99.0	99.0	28.0	H
	P42B0005A2-01	6.1 - 7.2		44.0	58.0	90.0	96.5	16.0	J
	P42B0007A2-01	5.9 - 6.9		51.0	61.0	99.0	98.5	18.0	F
	P42B0010A2-01	4.2 - 5.2		51.5	59.0				
	P42B0015A2-01	1.8 - 2.4		57.5	63.0	98.0	99.0	43.0	H
	P42B0005A1	1.3 - 1.8		49.0	61.0	99.0		36.4	K
	P42B0005A2	4.5 - 5.2		50.0	62.0	97.0		19.5	
	P42B0007A2	3.0 - 4.8		55.0	65.0	97.0	96.0	24.8	J
	P42B0010A2	4.2 - 5.2		58.0		94.0		21.7	F
	P42B0015A2	1.9 - 2.3		59.0	64.0	99.0	99.0	42.0	H
	P42B0005A1-02	2.0 - 2.5		42.5	55.0	98.0		25.0	G
	P42B0005A2-02	7.2 - 8.8		43.0	57.0	92.0	97.0	14.0	H
	P42B0007A2-02	5.7 - 7.1		54.0	63.5	99.0	99.0	17.0	F
	P42B0010A2-02	4.7 - 5.8		47.5	57.5			22.0	E
	P42B0015A2-02	2.7 - 3.3		56.5	62.0			34.0	F
CSIR 3-Wire	P43B0005A1-01	1.0 - 1.4	2.5 - 3.1	55.5	61.0	63.0	77.0	44.0	M
	P43B0005A2-01	5.1 - 6.1	12.4 - 13.7	51.0	58.0	60.0	75.0	20.5	L
	P43B0007A2-01	2.6 - 3.3	10.4 - 11.7	60.0	63.0	64.0	78.0	32.0	
	P43B0010A2-01	2.0 - 2.6	9.3 - 10.4	63.5	66.0	63.0	76.0	41.0	
	P43B0005A1	0.9 - 1.6	5.7 - 7.0	51.0	59.0	54.0	69.0	49.6	N
	P43B0005A2	4.2 - 4.9	17.4 - 18.7	50.0	58.0	58.0	71.0	22.3	M
	P43B0007A2	2.6 - 3.6	11.8 - 13.0	55.0	61.0	61.0	72.0	32.0	L
	P43B0010A2	2.2 - 3.2	11.3 - 12.3	59.0	62.0	66.0	75.0	41.2	
	P43B0005A1-02	1.5 - 1.9	3.1 - 3.9	54.0	58.5	68.0	82.0	41.0	K
	P43B0005A2-02	6.2 - 7.7	13.0 - 16.0	52.0	56.5	66.0	81.0	18.0	
	P43B0007A2-02	4.0 - 4.9	9.5 - 11.6	57.0	60.5	69.0		29.0	
P43B0010A2-02	3.3 - 4.1	11.9 - 14.6	60.5	62.5	74.0	82.0	39.0		
CSCR 3-Wire	P43B0005A2-01	5.1 - 6.1	12.4 - 13.7	52.0	63.0	75.0	86.0	21.0	L
	P43B0007A2-01	2.6 - 3.3	10.4 - 11.7	61.0	68.0	86.0	93.0	32.0	
	P43B0010A2-01	2.0 - 2.6	9.3 - 10.4	64.0	70.0	85.0	91.0	41.0	
	P43B0015A2-01	2.1 - 2.5	10.0 - 10.8	68.0	69.0	82.0	87.0	49.0	J
	P43B0005A2	4.2 - 4.9	17.4 - 18.7	52.0	62.0	76.0	85.0	22.3	M
	P43B0007A2	2.6 - 3.6	11.8 - 13.0	56.0	65.0	85.0	90.0	32.0	L
	P43B0010A2	2.2 - 3.2	11.3 - 12.3	62.0	68.0	86.0	92.0	41.2	
	P43B0015A2	1.6 - 2.3	7.9 - 8.7	66.0	67.0	80.0	85.0	47.8	J
	P43B0020A2	1.6 - 2.2	4.8 - 5.9	68.0	69.0	96.0	95.0	49.0	G
	P43B0030A2	1.0 - 1.4	2.0 - 2.5	72.0	72.0		97.0	76.0	
	P43B0050A2	0.6 - 0.8	1.3 - 1.7	70.5	71.0	97.0	97.5	101.0	E
	P43B0005A2-02	6.2 - 7.7	13.0 - 16.0	54.0	63.0	85.0	94.0	18.0	K
	P43B0007A2-02	4.0 - 4.9	9.5 - 11.6	56.0	64.5	91.0	96.0	29.0	
P43B0010A2-02	3.3 - 4.1	11.9 - 14.6	63.0	70.0	92.0	95.0	39.0		
P43B0015A2-02	2.6 - 3.3	8.0 - 9.8	66.5	67.0	84.0	89.0	43.0	H	

SECTION 5: XE SERIES 4" SUBMERSIBLE MOTORS

TABLE 5-4: THREE PHASE MOTOR SPECIFICATIONS

PENTEK PART NUMBER	LINE TO LINE RESISTANCE OHMS	% EFFICIENCY		LOCKED ROTOR AMPS	KVA CODE
		FL	SF		
P43B0005A8	4.1 - 5.2	64.0	69.5	22.0	R
P43B0005A3	5.7 - 7.2	65.0		18.0	
P43B0005A4	23.6 - 26.1	60.5	69.0	9.0	
P43B0007A8	2.8 - 3.7	68.0	73.0	30.0	
P43B0007A3	3.3 - 4.3	69.5	72.5	27.0	
P43B0007A4	14.4 - 16.2	68.0	73.5	14.0	
P43B0010A8	2.2 - 3.1	69.0	73.0	34.0	
P43B0010A3	3.2 - 4.2	70.0	72.5	26.0	M
P43B0010A4	16.8 - 18.6	65.5	71.5	15.0	N
P43B0015A8	1.9 - 2.5	73.0	74.5	40.0	L
P43B0015A3	2.5 - 3.1	72.0		36.0	
P43B0015A4	9.5 - 10.5	73.0	74.0	16.0	
P43B0015A5	15.6 - 17.3			15.0	
P43B0020A8	1.4 - 2.0	76.0	76.0	51.0	K
P43B0020A3	2.2 - 2.8		75.5	44.0	
P43B0020A4	7.5 - 9.3		76.5	23.0	L
P43B0020A5	10.2 - 12.5	78.0	78.0	21.0	M
P43B0030A8	1.2 - 1.5	77.0	77.0	71.0	K
P43B0030A3	1.6 - 2.0			59.0	
P43B0030A4	6.3 - 7.7			30.0	
P43B0030A5	10.2 - 12.5	78.0	78.0	21.0	J
P43B0050A8	0.7 - 0.9	76.0	76.0	113.0	
P43B0050A3	0.9 - 1.3			93.0	
P43B0050A4	3.9 - 4.9	77.0	77.0	48.0	
P43B0050A5	3.6 - 4.2	74.0	75.0	55.0	M
P43B0075A8	0.4 - 0.6		74.0	165.0	
P43B0075A3	0.5 - 0.9	75.0	75.0	140.0	J
P43B0075A4	2.1 - 2.7	76.0	76.0	87.0	L
P43B0075A5	3.6 - 4.2	77.0	77.0	55.0	J
P43B0100A4	1.8 - 2.2	79.0	80.0	110.0	K

SECTION 5: XE SERIES 4" SUBMERSIBLE MOTORS

5.5 - 4" MOTOR DIMENSIONS

TABLE 5-5: SINGLE PHASE MOTOR DIMENSIONS

MOTOR TYPE	PENTEK PART NUMBER	HP	KW	LENGTH		WEIGHT	
				INCHES	MM	LB	KG
4-Inch 2-Wire	P42B0005A1-01	1/2	0.37	10.5	266.7	18.1	8.2
	P42B0005A2-01						
	P42B0007A2-01	3/4	0.55	11.9	302.3	21.4	9.7
	P42B0010A2-01	1	0.75	12.5	317.5	23.2	10.5
	P42B0015A2-01	1-1/2	1.1	14.2	360.7	27.3	12.4
	P42B0005A1	1/2	0.37	11.0	279.0	19.2	8.7
	P42B0005A2						
	P42B0007A2	3/4	0.55	12.4	314.0	22.7	10.3
	P42B0010A2	1	0.75	13.3	337.0	24.5	11.1
	P42B0015A2	1-1/2	1.1	14.9	378.0	28.9	13.1
	P42B0005A1-02	1/2	0.37	10.5	266.7	18.1	8.2
	P42B0005A2-02						
	P42B0007A2-02	3/4	0.55	11.9	302.3	21.4	9.7
	P42B0010A2-02	1	0.75	12.5	317.5	23.2	10.5
P42B0015A2-02	1-1/2	1.1	14.2	360.7	27.3	12.4	
4-Inch 3-Wire	P43B0005A1-01	1/2	0.37	9.6	243.8	17.9	8.1
	P43B0005A2-01			9.2	233.7	16.7	7.6
	P43B0007A2-01	3/4	0.55	10.3	261.6	19.8	9.0
	P43B0010A2-01	1	0.75	11.2	284.5	22.0	10.0
	P43B0015A2-01	1-1/2	1.1	12.8	325.1	26.0	11.8
	P43B0005A1	1/2	0.37	10.0	253.0	18.9	8.6
	P43B0005A2			9.7	246.0	18.1	8.2
	P43B0007A2	3/4	0.55	10.8	275.0	21.4	9.7
	P43B0010A2	1	0.75	11.7	297.0	23.1	10.5
	P43B0015A2	1-1/2	1.1	13.6	345.0	27.4	12.4
	P43B0020A2	2	1.5	15.1	383.5	31.0	14.1
	P43B0030A2	3	2.2	18.3	464.8	40.0	18.1
	P43B0050A2	5	3.7	27.7	703.6	70.0	31.7
	P43B0005A1-02	1/2	0.37	9.6	243.8	17.9	8.1
	P43B0005A2-02			9.2	233.7	16.7	7.6
	P43B0007A2-02	3/4	0.55	10.3	261.6	19.8	9.0
	P43B0010A2-02	1	0.75	11.2	284.5	22.0	10.0
P43B0015A2-02	1-1/2	1.1	12.8	325.1	26.0	11.8	

SECTION 5: XE SERIES 4" SUBMERSIBLE MOTORS

TABLE 5-6: THREE PHASE MOTOR DIMENSIONS

PENTEK PART NUMBER	HP	KW	LENGTH		WEIGHT	
			INCHES	MM	LB	KG
P43B0005A8	1/2	0.37	10.0	254.0	18.9	8.6
P43B0005A3						
P43B0005A4						
P43B0007A8	3/4	0.55	10.8	274.3	21.4	9.7
P43B0007A3						
P43B0007A4						
P43B0010A8	1	0.75	11.7	297.2	23.1	10.5
P43B0010A3						
P43B0010A4						
P43B0015A8	1-1/2	1.10	13.8	350.5	27.4	12.4
P43B0015A3						
P43B0015A4						
P43B0015A5						
P43B0020A8	2	1.50	15.3	388.6	32.0	14.5
P43B0020A3						
P43B0020A4						
P43B0020A5						
P43B0030A8	3	2.20	21.7	551.2	55.0	24.9
P43B0030A3						
P43B0030A4						
P43B0030A5						
P43B0050A8	5	3.70	27.7	703.6	70.0	31.7
P43B0050A3						
P43B0050A4						
P43B0050A5						
P43B0075A8	7-1/2	5.50	30.7	779.8	78.0	35.4
P43B0075A3						
P43B0075A4						
P43B0075A5						
P43B0100A4	10	7.50	30.7	779.8	78.0	35.4

SECTION 5: XE SERIES 4" SUBMERSIBLE MOTORS

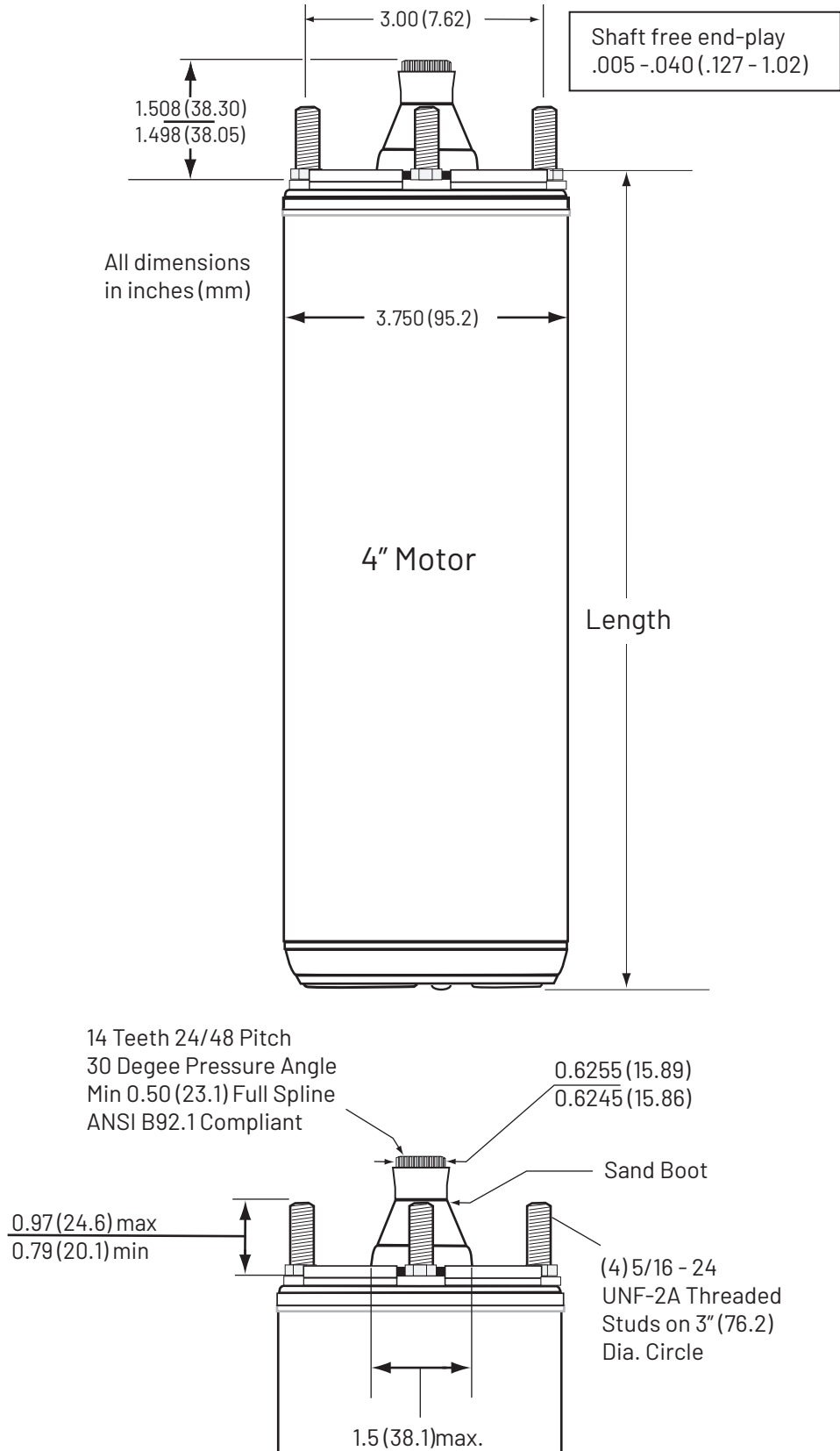

Figure 5-1: Single and Three Phase XE Series 4" Motor Dimensions

SECTION 5: XE SERIES 4" SUBMERSIBLE MOTORS

5.6 4" MOTOR FUSE SIZING

TABLE 5-7: SINGLE PHASE MOTOR FUSE SIZING

MOTOR TYPE	PENTEK PART NUMBER	HP	KW	VOLTS	FUSE SIZING BASED ON NEC			
					STANDARD FUSE	DUAL ELEMENT TIME DELAY FUSE	CIRCUIT BREAKER	
PSC 2-Wire	P42B0005A1-01	1/2	0.37	115	25	15	20	
	P42B0005A2-01			230	15	10	10	
	P42B0007A2-01	3/4	0.55	230			20	15
	P42B0010A2-01	1	0.75	230	30	20	25	
	P42B0015A2-01	1-1/2	1.1	230	25	15	20	
	P42B0005A1	1/2	0.37	115	20	15	10	
	P42B0005A2			230	15	10	15	
	P42B0007A2	3/4	0.55	230	25	15	20	
	P42B0010A2	1	0.75	230	30	20	25	
	P42B0015A2	1-1/2	1.1	230	25	15	20	
	P42B0005A1-02	1/2	0.37	115	20	15	10	
	P42B0005A2-02			230	15	10	15	
	P42B0007A2-02	3/4	0.55	230	25	15	20	
	P42B0010A2-02	1	0.75	230	30	20	25	
P42B0015A2-02	1-1/2	1.1	230	25	15	20		
CSIR 3-Wire	P43B0005A1-01	1/2	0.37	115	30	20	30	
	P43B0005A2-01			230	20	10	15	
	P43B0007A2-01	3/4	0.55	230	25	15	20	
	P43B0010A2-01	1	0.75	230	30	20	25	
	P43B0005A1	1/2	0.37	115	20	15	10	
	P43B0005A2			230	15	10	15	
	P43B0007A2	3/4	0.55	230	25	15	20	
	P43B0010A2	1	0.75	230	30	20	25	
	P43B0005A1-02	1/2	0.37	115	20	15	10	
	P43B0005A2-02			230	15	10	15	
	P43B0007A2-02	3/4	0.55	230	25	15	20	
	P43B0010A2-02	1	0.75	230	30	20	25	
	CSCR 3-Wire	P43B0005A2-01	1/2	0.37	230	20	10	15
		P43B0007A2-01	3/4	0.55	230	25	15	20
P43B0010A2-01		1	0.75	230	30	20	25	
P43B0015A2-01		1-1/2	1.1	230	15	10	15	
P43B0005A2		1/2	0.37	230	20	10	15	
P43B0007A2				3/4	0.55	230	25	15
P43B0010A2		1	0.75	230	30	20	25	
P43B0015A2		1-1/2	1.1	230	45	25	40	
P43B0020A2		2	1.5	230	80	45	60	
P43B0030A2		3	2.2	230	20	10	15	
P43B0050A2		5	3.7	230	25	15	20	
P43B0005A2-02		1/2	0.37	230	20	10	15	
P43B0007A2-02				3/4	0.55	230	25	15
P43B0010A2-02		1	0.75	230	30	20	25	
P43B0015A2-02	1-1/2	1.1	230	20	10	15		

SECTION 5: XE SERIES 4" SUBMERSIBLE MOTORS

TABLE 5-8: THREE PHASE MOTOR FUSE SIZING

PENTEK PART NUMBER	HP	KW	VOLTS	FUSE SIZING BASED ON NEC		
				STANDARD FUSE	DUAL ELEMENT TIME DELAY FUSE	CIRCUIT BREAKER
P43B0005A8	1/2	0.37	200	10	6	10
P43B0005A3			230	6		6
P43B0005A4			460	3	3	
P43B0007A8	3/4	0.55	200	15	10	10
P43B0007A3			230	6	6	6
P43B0007A4			460	3		3
P43B0010A8	1	0.75	200	15	10	10
P43B0010A3			230	10	6	
P43B0010A4			460	6	3	6
P43B0015A8	1-1/2	1.10	200	20	10	15
P43B0015A3			230	15		
P43B0015A4			460	10	6	6
P43B0015A5			575	6	3	
P43B0020A8	2	1.50	200	25	15	20
P43B0020A3			230	15		
P43B0020A4			460		6	10
P43B0020A5			575	10		
P43B0030A8	3	2.20	200	35	20	30
P43B0030A3			230	25	15	25
P43B0030A4			460	15	10	15
P43B0030A5			575	10		10
P43B0050A8	5	3.70	200	60	35	50
P43B0050A3			230	45	30	40
P43B0050A4			460	25	15	15
P43B0050A5			575	20		20
P43B0075A8	7-1/2	5.50	200	80	50	70
P43B0075A3			230	70	45	60
P43B0075A4			460	40	25	30
P43B0075A5			575	25	20	25
P43B0100A4	10	7.50	460	45	25	35

SECTION 5: XE SERIES 4" SUBMERSIBLE MOTORS

5.7 CABLE LENGTHS

TABLE 5-9: CABLE LENGTHS, SINGLE PHASE 115 AND 230 VOLT, 60 HZ, 3450 RPM, TWO AND THREE-WIRE MOTORS, 60° AND 75° C. SERVICE ENTRANCE TO MOTOR: MAXIMUM LENGTH IN FEET

MOTOR TYPE	PENTEK PART NUMBER	HP	VOLTS	FUSE SIZING BASED ON NEC											
				14	12	10	8	6	4	3	2	1	0	00	
PSC 2-Wire	P42B0005A1-01	1/2	115	107	171	273	432	672	1071	1346	1700	2142	2703	3411	
	P42B0005A2-01			457	726	1158	1835	2855	4551	5721	7225	9102	11489		
	P42B0007A2-01	3/4	230	342	545	869	1376	2141	3413	4291	5419	6826	8617	10871	
	P42B0010A2-01			267	425	678	1074	1671	2664	3349	4229	5328	6725	8485	
	P42B0015A2-01	1-1/2	115	230	209	332	530	839	1305	2080	2615	3303	4161	5252	6626
	P42B0005A1	115			183	293	463	721	1150	1445	1825	2299	2902	3662	
	P42B0005A2	3/4	230	466	742	1183	1874	2915	4648	5843	7379	9295	11733		
	P42B0007A2			342	545	869	1376	2141	3413	4291	5419	6826	8617	10871	
	P42B0010A2	1	115	230	241	383	611	968	1506	2400	3018	3811	4801	6060	7646
	P42B0015A2	1-1/2			199	317	505	801	1246	1986	2496	3153	3972	5013	6325
	P42B0005A1-02	1/2	115	230	110	174	278	440	685	1092	1373	1734	2184	2757	3479
	P42B0005A2-02				430	684	1090	1727	2687	4283	5384	6800	8566	10813	
	P42B0007A2-02	3/4	115	230	359	571	912	1444	2246	3581	4502	5685	7162	9040	11406
	P42B0010A2-02	1			274	436	695	1101	1713	2730	3433	4335	5461	6893	8697
	P42B0015A2-02	1-1/2	115	230	207	329	525	831	1293	2061	2591	3272	4121	5203	6564
	P43B0005A1-01	1/2			115	230	94	150	240	380	591	942	1184	1495	1883
P43B0005A2-01	348		553	883			1398	2175	3467	4359	5505	6935	8753		
P43B0007A2-01	3/4	115	230	277	441	704	1115	1734	2765	3476	4390	5530	6981	8807	
P43B0010A2-01	1			231	367	585	927	1442	2299	2891	3651	4599	5805	7324	
P43B0005A1	1/2	115	230	87	138	221	349	544	867	1090	1376	1734	2188	2761	
P43B0005A2				348	553	883	1398	2175	3467	4359	5505	6935	8753		
P43B0007A2	3/4	115	230	264	420	670	1061	1651	2632	3309	4178	5264	6644	8383	
P43B0010A2	1			226	359	573	908	1413	2252	2831	3575	4504	5685	7173	
P43B0005A1-02	1/2	115	230	100	158	253	400	623	993	1248	1576	1986	2507	3162	
P43B0005A2-02				391	622	993	1573	2447	3901	4904	6193	7801	9848		
P43B0007A2-02	3/4	115	230	296	471	751	1190	1852	2952	3711	4686	5904	7452	9402	
P43B0010A2-02	1			243	387	618	978	1522	2427	3051	3853	4854	6127	7731	
P43B0005A2-01	1/2	230	438	697	1112	1761	2740	4369	5492	6936	8738	11029			
P43B0007A2-01	3/4		359	571	912	1444	2246	3581	4502	5685	7162	9040	11406		
P43B0010A2-01	1		296	471	751	1190	1852	2952	3711	4686	5904	7452	9402		
P43B0015A2-01	1-1/2		199	317	505	801	1246	1986	2496	3153	3972	5013	6325		
P43B0005A2	1/2		447	711	1135	1797	2796	4458	5604	7078	8916	11254			
P43B0007A2	3/4		348	553	883	1398	2175	3467	4359	5505	6935	8753	11044		
P43B0010A2	1		304	484	772	1223	1903	3034	3814	4817	6068	7659	9663		
P43B0015A2	1-1/2		197	314	501	793	1234	1968	2474	3124	3936	4968	6268		
P43B0020A2	2		180	286	456	722	1123	1790	2251	2843	3581	4520	5703		
P43B0030A2	3		133	211	337	534	830	1324	1664	2102	2648	3342	4217		
P43B0050A2	5				206	326	507	809	1017	1284	1618	2042	2577		
P43B0005A2-02	1/2		476	758	1209	1914	2979	4749	5970	7539	9497	11988			
P43B0007A2-02	3/4		359	571	912	1444	2246	3581	4502	5685	7162	9040	11406		
P43B0010A2-02	1		309	491	783	1240	1930	3077	3868	4884	6153	7767	9799		
P43B0015A2-02	1-1/2		205	326	520	823	1281	2041	2566	3241	4083	5154	6502		

SECTION 5: XE SERIES 4" SUBMERSIBLE MOTORS

TABLE 5-10: CABLE LENGTHS, THREE PHASE 230, 460, 200, AND 575 VOLT, 60 HZ, 3450 RPM MOTORS, 60° AND 75° C. SERVICE ENTRANCE TO MOTOR: MAXIMUM LENGTH IN FEET

PENTEK PART NUMBER	HP	VOLTS	FUSE SIZING BASED ON NEC										
			14	12	10	8	6	4	3	2	1	0	00
P43B0005A8	1/2	200	629	1000	1595	2526	3931						
P43B0005A3		230	844	1342	2140	3389	5274	8408	10570				
P43B0005A4		460	3374	5367	8561								
P43B0007A8	3/4	200	468	745	1188	1881	2927						
P43B0007A3		230	633	1006	1605	2542	3956	6306	7927	10011			
P43B0007A4		460	2531	4025	6420	10168							
P43B0010A8	1	200	386	614	979	1551	2414	3848	4837				
P43B0010A3		230	516	821	1310	2075	3229	5148	6471	8172			
P43B0010A4		460	2024	3220	5136	8135							
P43B0015A8	1-1/2	200	290	461	735	1163	1810	2886	3628				
P43B0015A3		230	383	610	973	1541	2397	3822	4804	6067	7643	9648	
P43B0015A4		460	1489	2368	3777	5981							
P43B0015A5		575	2433	3870	6173								
P43B0020A8	2	200	237	376	600	951	1479	2358	2965	3744	4717	5954	
P43B0020A3		230	316	503	803	1271	1978	3153	3964	5006	6306	7960	10042
P43B0020A4		460	1234	1964	3132	4960	7718						
P43B0020A5		575	1917	3049	4864	7703							
P43B0030A8	3	200	183	292	465	737	1147	1828	2298	2902	3656	4614	
P43B0030A3		230	251	399	636	1007	1567	2497	3140	3965	4995	6305	7954
P43B0030A4		460	955	1519	2423	3837	5971						
P43B0030A5		575	1543	2454	3915	6200							
P43B0050A8	5	200	109	173	276	438	681	1086	1365	1724	2172	2741	3458
P43B0050A3		230	145	230	367	581	904	1441	1812	2288	2883	3639	4591
P43B0050A4		460	595	947	1511	2393	3723	5935					
P43B0050A5		575	832	1324	2112	3345	5205						
P43B0075A8	7-1/2	200	73	117	186	295	459	731	919	1161	1462	1846	2329
P43B0075A3		230	96	152	243	385	599	955	1201	1517	1911	2412	3043
P43B0075A4		460	375	596	951	1506	2344	3737	4698	5933	7474		
P43B0075A5		575	633	1006	1605	2542	3956						
P43B0100A4	10	460	294	468	747	1182	1840	2933	3687	4656	5866		

SECTION 5: XE SERIES 4" SUBMERSIBLE MOTORS

5.8 4" MOTOR OVERLOAD PROTECTION

SINGLE PHASE MOTORS

Single phase motors have overload protection either in the motor or in the control box. Motors less than or equal to 1 HP have built-in protection. This automatic protection will continue to cycle under a locked or stalled rotor condition.

Single phase motors larger than 1 HP use overload protection located in the SMC (Submersible Motor Controls) section. These are manual overloads and must be manually reset if an overload condition occurs.

5.9 MOTOR COOLING

Pentek® 4" XE Series motors are designed to operate to a maximum SF (Service Factor) horsepower in water up to 86° F (30° C).

4" MOTORS: MINIMUM COOLING WATER FLOW 3 HP AND OVER

I.D OF CASING	FLOW GPM (LPM) REQUIRED
4	1.2 (4.5)
5	7 (26.5)
6	13 (49)
7	20 (76)
8	30 (114)
10	50 (189)
12	80 (303)
14	110 (416)
16	150 (568)

If the flow is less than specified, a flow-inducer sleeve can be installed, as shown in Figure 5-2. The sleeve will act like a smaller casing size to force flow around the motor to aid cooling.

5.10 STARTING FREQUENCY

Recommended motor starting frequency is shown below. Motor, pressure switch, tank, and pump life may be extended by limiting starts per hour and starts per day. Proper tank sizing is critical to control pump cycle times. Excessive or rapid cycling creates heat which can prematurely damage motors, switches, and controls.

MOTOR STARTING FREQUENCY				
HP	SINGLE PHASE		THREE PHASE	
	STARTS/HR	STARTS/24HR	STARTS/HR	STARTS/24HR
1/2 thru 3/4	12.5	300	12.5	300
1 thru 5	4.2	100		
7.5 thru 200			4.2	100

A one (1) minute minimum run time for pumps and motors up to 1.5 HP and two (2) minutes for 2 HP and larger motors is recommended to dissipate heat build-up from starting current.

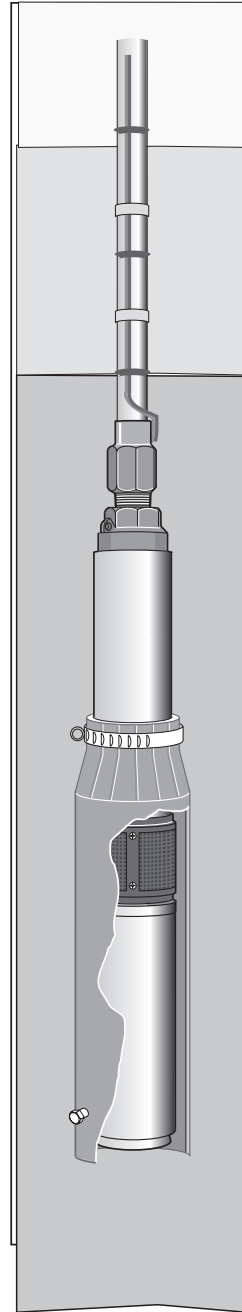

Figure 5-2: Flow Inducer Sleeve

SECTION 6: PENTEK 6" AND 8" SUBMERSIBLE MOTORS

6.1 MOTOR INSPECTION

6" APPLICATION LIMITS

- ◆ Maximum Immersion Depth: 985 ft. (300 m).
- ◆ Maximum Water Temperature: 95°F (35°C).
- ◆ pH content of the water: 6.5–8.
- ◆ Minimum Cooling Flow Rate: 0.5 feet per second (fps) (0.15meters per second (mps)).
- ◆ Required line voltage at the motor under operating conditions ($\pm 10\%$).
- ◆ When calculating voltage at the motor, be sure to allow for voltage drop in the cable.
- ◆ The sum of the absolute values of the voltage and frequency must not vary from the sum of the nominal values by more than $\pm 10\%$.
- ◆ Operating with current unbalanced on the three legs of the circuit can overheat and damage the motor and will void the warranty. Current imbalance must not exceed 5% maximum.
- ◆ Maximum Sand Content: 50ppm (max. size 0.1–0.25mm).
- ◆ Maximum Chlorine Ion Content: 500ppm.

8" APPLICATION LIMITS

- ◆ Maximum Immersion Depth: 1148 ft. (350 m).
- ◆ Maximum Water Temperature: 95°F (35°C).
- ◆ pH content of the water: 6 – 8.
- ◆ Minimum Cooling Flow Rate: 0.5 feet per second (fps) (0.15meters per second (mps)).
- ◆ Required line voltage at the motor under operating conditions ($\pm 10\%$).
- ◆ When calculating voltage at the motor, be sure to allow for voltage drop in the cable.
- ◆ The sum of the absolute values of the voltage and frequency must not vary from the sum of the nominal values by more than $\pm 10\%$.
- ◆ Operating three-phase motors with current unbalanced on the three legs of the circuit can overheat and damage the motor and will void the warranty. Current imbalance must not exceed 5% maximum.
- ◆ Maximum Sand Content: 50ppm (max. size 0.1–0.25mm).
- ◆ Maximum Chlorine Ion Content: 4ppm.

6.2 TESTING

ELECTRICAL

1. **⚠ WARNING RISK OF ELECTRICAL SHOCK IF THE CABLE IS DAMAGED.** Inspect the motor cable for any nicks or cuts. Do not use the motor cable to pull, lift, or handle the motor. Protect the motor cable during storage, handling, moving, and installation of the motor.
2. Inspect the motor to determine that it is the correct horsepower, voltage, and size for the job and that there is no shipping damage. Verify that the motor nameplate voltage matches the available power supply voltage. The nameplate rated voltage must not vary more than $\pm 10\%$ from the power supply voltage.
3. On all new installations and after the motor has sat idle for a long period of time, check the motor's internal electrical resistance with a megohmmeter with lead wires connected. Prior to installation, the motor should have an insulation value of at least 500 megohms. After installation, the motor and power cable should have a minimum insulation value of 1 megohm. If the minimum values are below the listed values, contact the factory before starting the motor.
4. Fuses or circuit breakers and overload protection are required. Fuses or circuit breakers and overloads must be sized in accordance with National Electrical Code (NEC) or Canadian Electrical Code (CEC) requirements, as applicable, and with all applicable local codes and ordinances. See Section 6 for these specifications.
5. Wire and ground the motor in accordance with National Electrical Code (NEC) or Canadian Electrical Code (CEC) requirements, as applicable, and with all applicable local codes and ordinances.

6.3 STORAGE AND DRAIN/FILL INSTRUCTIONS

LIFTING

1. **⚠ WARNING HEAVY OBJECT.** Lifting equipment must be capable of lifting motor and attached equipment. Check over all tools, especially the hoisting gear, for wear or damage before hoisting the unit.
2. If the total length of the pump and motor unit (without any riser pipe attached) exceeds 10ft (3m), support the unit with a girder while hoisting (see Figure 6-1). Do not remove the supporting girder until the unit is standing vertically in the hoist. Check for damage.

SECTION 6: PENTEK 6" AND 8" SUBMERSIBLE MOTORS

6.3 STORAGE AND DRAIN/FILL INSTRUCTIONS

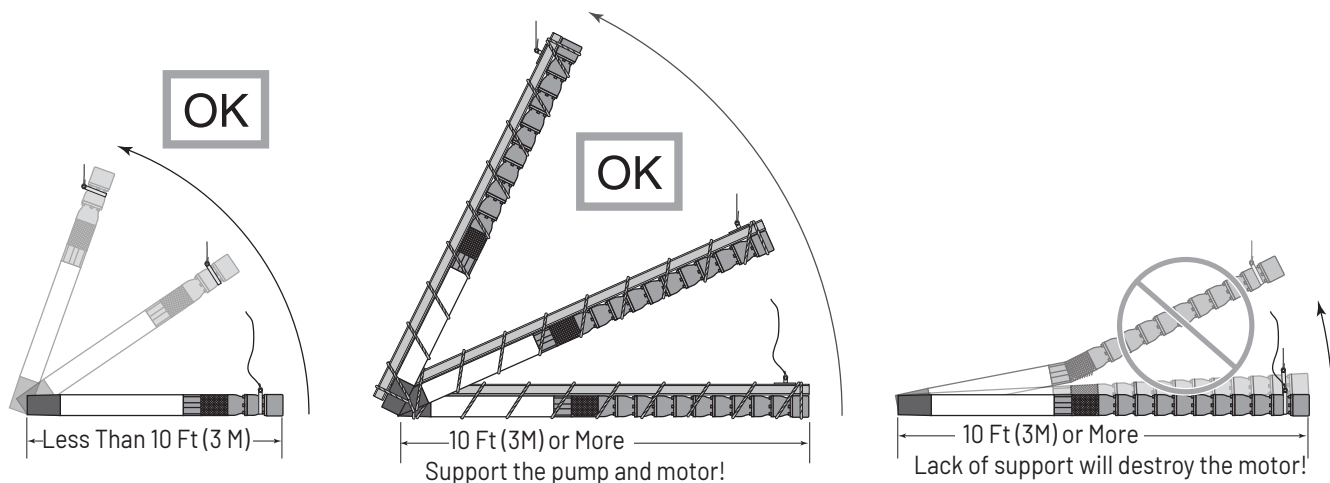

Figure 6-1: When the pump and motor together (without any riser pipe) are 10ft (3m) long or more, support the assembly before lifting to avoid bending it in the middle. Never try to lift the motor or pump by the motor cables.

MOTOR STORAGE AND INSTALLATION

1. The motor is filled at the factory with anti-freeze which will protect it in temperatures down to -22°F (-30°C). Do not install, transport or store the motor below these temperatures if the motor is filled. If storage is necessary at temperatures below -22°F (-30°C), drain the anti-freeze from the motor.
2. Verify that the motor is full before installing. If not, fill it with clean water (see below). Installing a motor that is not filled with liquid will void the warranty. Before installation, check all water fill and drain plugs, mounting bolts, and cable connections for tightness. Refill the motor with clean water as follows:
 - A. Stand the motor on end (vertically) and remove the fill plug with a 5mm hexagonal nut driver.
 - B. Turn the motor shaft by hand while rocking the motor back and forth (see Figure 6-2). **CAUTION** Support motor while rocking to prevent motor from falling over.
 - C. Pour in clean water until the motor is as full as possible.
 - D. Repeat the turning/rocking procedure.
 - E. Check the liquid level. If necessary, add more clean water.
 - F. When the motor is full, re-install the fill plug. Tighten it with the 5mm hexagonal nut driver.

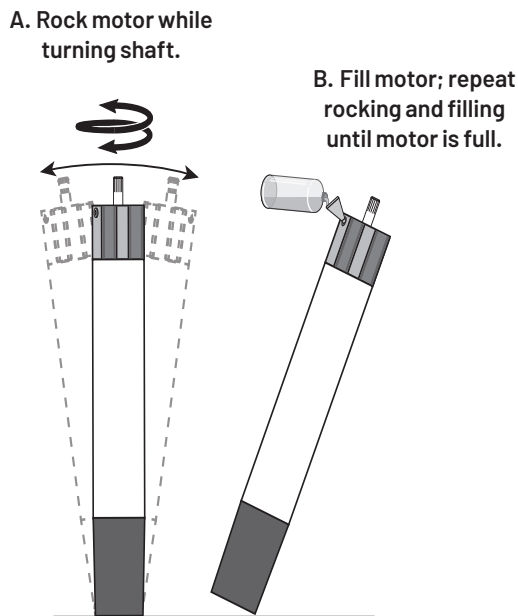

Figure 6-2: Rock Motor gently from side to side while turning shaft by hand (A), then fill with clean water (B). Repeat until full.

SECTION 6: PENTEK 6" AND 8" SUBMERSIBLE MOTORS

6.3 STORAGE AND DRAIN/FILL INSTRUCTIONS

To avoid damaging the motor thrust bearing, do not hammer on the shaft, coupling, or slinger. Check the motor rotation by hand to make sure that it turns freely.

1. To avoid damage to the motor diaphragm, make sure that the bottom of the motor does not touch the dirt or mud at the bottom of the well. Install the motor at least 10' above the well bottom.
2. To install the motor horizontally, lay it down with the lead wires at 12 o'clock when you are facing the motor shaft. To prevent any load on the shaft and bearings and to avoid any damaging vibrations to the motor, mount the motor solidly on the pump end and make sure that the pump and motor are accurately aligned.
3. Install the motor so that during operation water flows past all parts of it at a rate of at least 0.5 fps (0.15 mps). If the well will not provide this flow, install a sleeve on the motor to channel water past it (see Figure 6-3). Do not try to operate the motor in mud or sand. To do so will damage the motor and void the warranty.
4. Electrical connections: Connect the three motor leads to the three hot motor leads (black, brown, and blue) in the incoming cable. Connect the ground wire (green and yellow) in accordance with NEC or CEC requirements (as applicable) and in accordance with all applicable local codes and ordinances. Apply power momentarily to check rotation. If the motor runs backwards, interchange any two power leads to reverse direction of rotation.

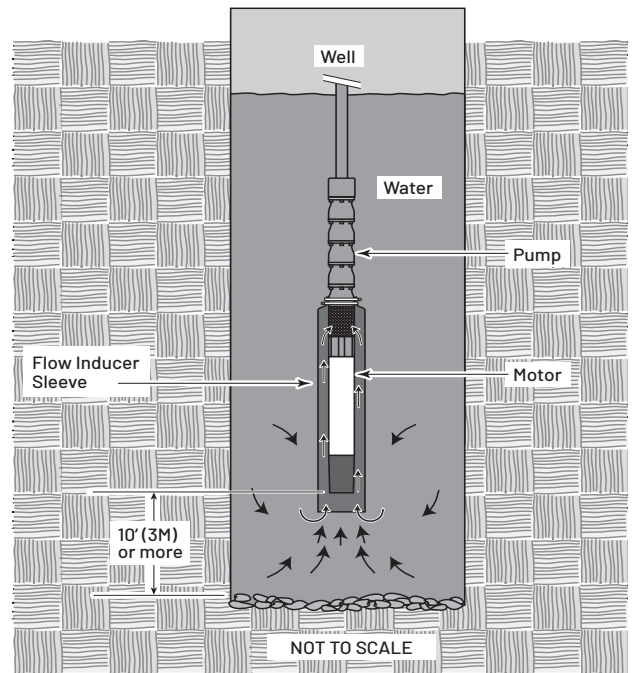

Figure 6-3: If flow past motor is less than .5 fps (0.15 mps), install a flow inducer sleeve as shown. Flow must be at least .5 fps (0.15 mps) for adequate motor cooling. The flow inducer sleeve should not touch the side of the motor.

SECTION 6: PENTEK 6" AND 8" SUBMERSIBLE MOTORS

6.4 MOTOR SPECIFICATIONS

TABLE 5-10: CABLE LENGTHS, THREE PHASE 230, 460, 200, AND 575 VOLT, 60 HZ, 3450 RPM MOTORS, 60° AND 75° C. SERVICE ENTRANCE TO MOTOR: MAXIMUM LENGTH IN FEET

PHASE	MOTOR DIAMETER	PENTEK PART NUMBER	HP	VOLTS	KW	FULL LOAD			SERVICE FACTOR 1.15			LOCKED ROTOR AMPS	THRUST LOAD	KVA CODE	WINDING RESISTANCE (OHM)		RPM	LENGTH		WEIGHT			
						AMPS (B OR Y/B/R)	EFF%	PF%	AMPS (B OR Y/B/R)	EFF%	PF%				MAIN (B-Y OR B-B)	START (R-Y)		IN	MM	LBS	KG		
1		P60A0050A2	5	230	3.7	22.8/16.5/9.0	74.5	97.0	26.0/18.9/8.9	75.5	97.0	104.0	3600	E	0.54 - 0.67	1.7 - 2.1	3450	25.6	650.2	104.0	47.2		
		P60A0075A2	7-1/2	230	5.5	35.2/30.7/8.3	77.0	92.0	40.0/35.1/7.9	77.5	92.5	162.0		F	0.36 - 0.44	0.76 - 0.94		28.1	713.7	117.0	53.1		
		P60A0100A2	10	230	7.5	45.7/38.2/12.7	76.5	94.0	52.4/45.1/12.5	76.5	94.0	202.0		E	0.25 - 0.31	0.69 - 0.85		30.3	769.6	132.0	59.9		
		P60A0150A2	15	230	11.0	62.4/46.6/19.9	81.5	98.0	72.5/54.7/19.6	81.5	98.0	296.0		E	0.22 - 0.28	0.61 - 0.75		32.8	833.1	144.0	65.3		
3	6"	P60A0050A8	5	200	3.7	16.1	77.5	86.5	18.0	78.5	88.0	96.0	3600	H	0.86 - 1.1	3450	3450	23.0	584.2	87.0	39.5		
		P60A0050A3		230		14.4			16.1			87.0			1.1 - 1.4								
		P60A0050A4		460		7.0			8.0			44.0			4.4 - 5.4								
		P60A0050A5		575		5.8			6.5			35.0			5.8 - 7.2								
		P60A0075A8	7-1/2	200	5.5	23.3	80.0	87.5	26.8	80.0	88.5	140.0			0.66 - 0.81								
		P60A0075A3		230		21.5			24.1			127.0			0.73 - 0.90								
		P60A0075A4		460		10.0			11.3			62.0			2.9 - 3.6								
		P60A0075A5		575		8.2			9.3			51.0			3.6 - 4.4								
		P60A0100A8	10	200	7.5	31.5	82.5	86.5	35.0	82.5	88.0	187.0			0.37 - 0.46								
		P60A0100A3		230		28.0			31.5			164.0			0.50 - 0.62								
		P60A0100A4		460		13.1			14.8			82.0			1.9 - 2.4								
		P60A0100A5		575		10.5			11.8			61.0											
	P60A0150A8	15	200	11.0	44.9	83.5	87.0	50.8	83.5	88.5	268.0	0.26 - 0.32											
	P60A0150A3		230		40.9			46.3			237.0	0.33 - 0.41											
	P60A0150A4		460		20.4			23.0			117.0	1.1 - 1.4											
	P60A0150A5		575		15.0			17.1			88.0	1.9 - 2.4											
	P60A0200A8	20	200	15.0	59.0	83.0	87.5	67.1	83.0	89.0	354.0	0.19 - 0.24											
	P60A0200A3		230		53.2			60.8			312.0	0.25 - 0.31											
	P60A0200A4		460		25.8			29.4			151.0	0.9 - 1.1											
	P60A0200A5		575		20.9			23.7			122.0	1.4 - 1.7											
	P60A0250A8	25	200	19.0	76.8	84.0	85.5	86.5	84.0	87.5	445.0	0.13 - 0.17											
	P60A0250A3		230		66.7			76.0			387.0	0.18 - 0.22											
	P60A0250A4		460		32.8			36.8			187.0	0.69 - 0.85											
	P60A0250A5		575		26.2			29.7			153.0	1.0 - 1.3											
P60A0300A8	30	200	22.0	91.7	84.5	86.0	103.3	84.5	87.5	530.0	0.10 - 0.13												
P60A0300A3		230		79.3			90.2			458.0	0.15 - 0.19												
P60A0300A4		460		39.3			44.6			226.0	0.58 - 0.72												
P60A0300A5		575		31.0			35.0			179.0	0.83 - 1.0												
P60A0400A4	40	460	30.0	51.3	85.0	87.5	58.6	85.0	89.0	302.0	0.45 - 0.56												
P60A0400A5		575		41.5			47.3			247.0	0.64 - 0.79												
P60A0500A4	50	460	37.0	65.8	84.0	87.0	75.1	84.0	88.0	385.0	0.35 - 0.43												
P80A0500A4		37.0		52.0			60.0			88.0	439.0	.32 - .39											
P80A0500A5		575	45.0	61.0			88.0			70.0	88.5	518.0	.26 - .32										
P80A0600A4		60	460	56.0			76.0			86.5	88.5	88.0	86.5	89.0	645.0	.20 - .25							
P80A0600A5	575		75.0	100.0	87.5	87.5	115.0	87.5	88.5	855.0	.16 - .20												
P80A0750A4	75	460	93.0	129.0	84.5	87.0	148.0	85.0	87.5	1133.0	.10 - .13												
P80A0750A5		575	112.0	159.0		85.5	178.0		86.5	1320.0	.08 - .10												
P80A1000A4	100	460	37.0	52.0	85.5	87.0	60.0	86.0	88.0	439.0	.32 - .39												
P80A1000A5		575	45.0	61.0		88.0	70.0		88.5	518.0	.26 - .32												
P80A1250A4	125	460	56.0	76.0	86.5	88.5	88.0	86.5	89.0	645.0	.20 - .25												
P80A1250A5		575	75.0	100.0		87.5	87.5		115.0	87.5	88.5	855.0	.16 - .20										
P80A1500A4	150	460	93.0	129.0	84.5	87.0	148.0	85.0	87.5	1133.0	.10 - .13												
P80A1500A5		575	112.0	159.0		85.5	178.0		86.5	1320.0	.08 - .10												
3	8"	P80A0500A4	50	460	37.0	65.8	84.0	87.0	75.1	84.0	88.0	385.0	10000	K	0.35 - 0.43	3450	3450	54.1	1374.1	265.0	120.2		
		P80A0500A4		37.0		52.0			60.0			88.0			439.0							.32 - .39	
		P80A0500A5		575	45.0	61.0			88.0			70.0			88.5							518.0	.26 - .32
		P80A0600A4		60	460	56.0			76.0			86.5			88.5							88.0	86.5
		P80A0600A5	575		75.0	100.0	87.5	87.5	115.0	87.5	88.5	855.0			.16 - .20								
		P80A0750A4	75	460	93.0	129.0	84.5	87.0	148.0	85.0	87.5	1133.0			.10 - .13								
		P80A0750A5		575	112.0	159.0		85.5	178.0		86.5	1320.0			.08 - .10								
		P80A1000A4	100	460	37.0	52.0	85.5	87.0	60.0	86.0	88.0	439.0			.32 - .39								
		P80A1000A5		575	45.0	61.0		88.0	70.0		88.5	518.0			.26 - .32								
		P80A1250A4	125	460	56.0	76.0	86.5	88.5	88.0	86.5	89.0	645.0			.20 - .25								
		P80A1250A5		575	75.0	100.0		87.5	87.5		115.0	87.5			88.5			855.0	.16 - .20				
		P80A1500A4	150	460	93.0	129.0	84.5	87.0	148.0	85.0	87.5	1133.0			.10 - .13								
P80A1500A5	575	112.0		159.0	85.5	178.0		86.5	1320.0		.08 - .10												

SECTION 6: PENTEK 6" AND 8" SUBMERSIBLE MOTORS

6.5 MOTOR DIMENSIONS

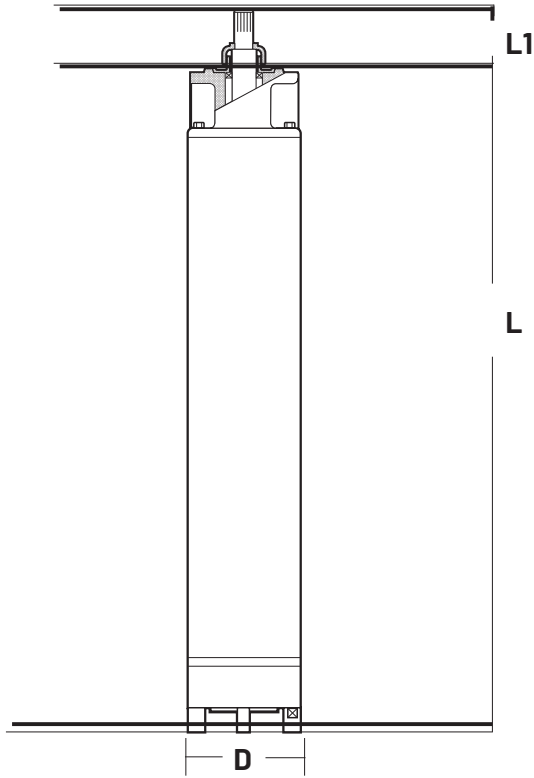

Nominal diameter	6"/152.4 mm
Effective diameter	5.43"/138 mm
Shaft extension length	2.87"/73 mm

For lengths, refer to Ordering Information tables.
Dimensions are for estimating purposes only.

Figure 6-4: Dimensions

SECTION 6: PENTEK 6" AND 8" SUBMERSIBLE MOTORS

6.6 MOTOR FUSE SIZING AND CABLE SELECTION

CABLE SELECTION: COPPER CABLE SIZE - FROM MAIN BREAKER PANEL TO MOTOR (IN FEET)

60°

PHASE	MOTOR DIAMETER	PENTEK PART NUMBER	HP	MOTOR				AWG														MCM						
				VOLTS	KW	FUSE SIZING BASED ON NEC			14	12	10	8	6	4	3	2	1	0	00	000	0000	250	300	350	400	500		
						STANDARD FUSE	DUAL ELEMENT TIME DELAY FUSE	CIRCUIT BREAKER																				
1		P60A0050A2	5	230	3.7	80	50	70		132	210	332	517	825	1037	1309	1649	2082	2626	3315	4177	4931						
		P60A0075A2	7-1/2		5.5	125	80	110			136	216	336	536	674	851	1072	1353	1707	2155	2715	3205	3848	4498				
		P60A0100A2	10		7.5	175	90	125				165	257	409	514	650	818	1033	1303	1645	2073	2447	2937	3434	3926	4884		
		P60A0150A2	15		11.0	225	150	200					185	296	372	469	591	746	942	1189	1498	1768	2122	2481	2837	3529		
6"		P60A0050A8	5	200	3.7	60	35	50	125	199	317	502	780	1244	1564	1975	2488	3141	3962	5002								
		P60A0075A8	7-1/2		5.5	90	50	70		133	213	337	524	836	1050	1327	1671	2109	2661	3360	4233	4997						
		P60A0100A8	10		7.5	110	70	100			163	258	401	640	804	1016	1280	1615	2038	2573	3241	3826	4593	5369				
		P60A0150A8	15		11.0	175	100	125				178	277	441	554	700	882	1113	1404	1772	2233	2636	3165	3699	4230	5262		
		P60A0200A8	20		15.0	225	125	175					209	334	420	530	667	843	1063	1342	1691	1996	2396	2801	3202	3984		
		P60A0250A8	25		19.0	300	150	200						259	325	411	518	654	825	1041	1311	1548	1859	2173	2484	3091		
		P60A0300A8	30		22.0	350	200	250							217	273	344	434	547	690	872	1098	1296	1556	1819	2080	2588	
		P60A0050A3	5		3.7	60	35	45	154	245	391	620	965	1538	1933	2442	3076	3883	4899									
		P60A0075A3	7-1/2	5.5	80	45	70	103	164	262	414	645	1027	1292	1631	2055	2594	3273	4131	5205								
		P60A0100A3	10	7.5	100	60	90			200	317	493	786	988	1248	1572	1985	2504	3161	3982	4701	5644						
		P60A0150A3	15	11.0	150	90	125				216	335	535	672	849	1070	1350	1703	2150	2709	3198	3840	4488	5132				
		P60A0200A3	20	15.0	200	110	175					255	407	512	647	815	1028	1297	1638	2063	2436	2924	3418	3908	4862			
		P60A0250A3	25	19.0	225	150	200					204	326	410	517	652	823	1038	1310	1650	1949	2339	2734	3126	3890			
		P60A0300A3	30	22.0	300	175	225						275	345	436	549	693	874	1104	1391	1642	1971	2304	2634	3277			
		3		P60A0050A4	5	460	3.7	30	15	25	621	988	1576	2496	3883													
				P60A0075A4	7-1/2		5.5	40	25	35	440	699	1116	1767	2749	4383	5510											
				P60A0100A4	10		7.5	50	30	40	336	534	852	1349	2099	3346	4207	5312										
				P60A0150A4	15		11.0	70	45	60	216	344	548	868	1351	2153	2707	3418	4306	5436								
				P60A0200A4	20		15.0	90	50	80		269	429	679	1057	1684	2118	2674	3369	4253	5365							
				P60A0250A4	25		19.0	110	70	100			343	543	844	1346	1692	2137	2691	3397	4286	5411						
P60A0300A4	30			22.0	150		80	110				448	697	1110	1396	1763	2221	2803	3537	4465	5625							
P60A0400A4	40			30.0	175		100	150				341	530	845	1062	1342	1690	2134	2692	3398	4281	5054						
P60A0500A4	50			37.0	225	150	175					414	659	829	1047	1319	1665	2100	2652	3341	3944	4734	5534					
P60A0050A5	5			3.7	25	15	20	955	1520	2424	3839																	
P60A0075A5	7-1/2			5.5	30	20	25	668	1062	1694	2683	4175																
P60A0100A5	10			7.5	40	25	30	526	837	1335	2115	3291	5246															
P60A0150A5	15	11.0	60	30	45	363	578	921	1459	2271	3620	4551	5747															
P60A0200A5	20	15.0	80	45	60	262	417	665	1053	1638	2612	3284	4147	5224														
P60A0250A5	25	19.0	90	60	80		333	531	840	1307	2084	2620	3309	4169	5262													
P60A0300A5	30	22.0	110	70	90			450	713	1109	1769	2224	2808	3537	4465	5633												
P60A0400A5	40	30.0	150	90	125				528	821	1309	1645	2078	2618	3304	4169	5262											
8"		P80A0500A4	50	460	37.0	225	125	175					420	669	841	1062	1338	1690	2132	2691	3390	4002	4805	5616				
		P80A0600A4	60		45.0	250	150	200							556	700	883	1113	1405	1772	2237	2819	3328	3995	4670	5339		
		P80A0750A4	75		56.0	350	200	250								571	721	909	1147	1447	1827	2302	2717	3262	3813	4359	5424	
		P80A1000A4	100		75.0	400	250	350										678	856	1080	1364	1718	2029	2435	2847	3255	4049	
		P80A1250A4	125		93.0	600	350	450											665	839	1059	1334	1575	1891	2211	2528	3145	
		P80A1500A4	150	112.0	700	400	500												692	873	1100	1299	1559	1823	2084	2593		
		P80A0500A5	50	37.0	225	125	175				416	647	1032	1297	1638	2063	2605	3286	4149	5227								
		P80A0600A5	60	45.0	250	150	200					555	884	1112	1404	1769	2233	2817	3556	4480	5289							
		P80A0750A5	75	56.0	350	200	250						703	884	1117	1407	1776	2241	2829	3564	4207	5050						
		P80A1000A5	100	75.0	400	250	350							677	855	1077	1359	1715	2164	2727	3219	3865	4518	5165				
P80A1250A5	125	93.0	600	350	450										837	1056	1332	1682	2119	2502	3003	3510	4013	4993				
P80A1500A5	150	112.0	700	400	500											878	1108	1398	1762	2080	2497	2919	3337	4152				

SECTION 6: PENTEK 6" AND 8" SUBMERSIBLE MOTORS

CABLE SELECTION: COPPER CABLE SIZE - FROM MAIN BREAKER PANEL TO MOTOR (IN FEET)

75°

PHASE	MOTOR DIAMETER	PENTEK PART NUMBER	HP	MOTOR				AWG																MCM					
				VOLTS	KW	FUSE SIZING BASED ON NEC			14	12	10	8	6	4	3	2	1	0	00	000	0000	250	300	350	400	500			
						STANDARD FUSE	DUAL ELEMENT TIME DELAY FUSE	CIRCUIT BREAKER																					
1	6"	P60A0050A2	5	230	3.7	80	50	70		132	210	332	517	825	1037	1309	1649	2082	2626	3315	4177	4931							
		P60A0075A2	7-1/2		5.5	125	80	110			136	216	336	536	674	851	1072	1353	1707	2155	2715	3205	3848	4498					
		P60A0100A2	10		7.5	175	90	125				165	257	409	514	650	818	1033	1303	1645	2073	2447	2937	3434	3926	4884			
		P60A0150A2	15		11.0	225	150	200					185	296	372	469	591	746	942	1189	1498	1768	2122	2481	2837	3529			
		P60A0050A8	5	200	3.7	60	35	50	125	199	317	502	780	1244	1564	1975	2488	3141	3962	5002									
		P60A0075A8	7-1/2		5.5	90	50	70	84	133	213	337	524	836	1050	1327	1671	2109	2661	3360	4233	4997							
		P60A0100A8	10		7.5	110	70	100			102	163	258	401	640	804	1016	1280	1615	2038	2573	3241	3826	4593	5369				
		P60A0150A8	15		11.0	175	100	125					178	277	441	554	700	882	1113	1404	1772	2233	2636	3165	3699	4230	5262		
		P60A0200A8	20		15.0	225	125	175					135	209	334	420	530	667	843	1063	1342	1691	1996	2396	2801	3202	3984		
		P60A0250A8	25		19.0	300	150	200						162	259	325	411	518	654	825	1041	1311	1548	1859	2173	2484	3091		
		P60A0300A8	30		22.0	350	200	250							217	273	344	434	547	690	872	1098	1296	1556	1819	2080	2588		
		P60A0050A3	5		230	3.7	60	35	45	178	245	391	620	965	1538	1933	2442	3076	3883	4899									
P60A0075A3	7-1/2	5.5	80			45	70	103	164	262	414	645	1027	1292	1631	2055	2594	3273	4131	5205									
P60A0100A3	10	7.5	100			60	90		125	200	317	493	786	988	1248	1572	1985	2504	3161	3982	4701	5644							
P60A0150A3	15	11.0	150	90		125			136	216	335	535	672	849	1070	1350	1703	2150	2709	3198	3840	4488	5132						
P60A0200A3	20	15.0	200	110		175				164	255	407	512	647	815	1028	1297	1638	2063	2436	2924	3418	3908	4862					
P60A0250A3	25	19.0	225	150		200					204	326	410	517	652	823	1038	1310	1650	1949	2339	2734	3126	3890					
P60A0300A3	30	22.0	300	175		225						172	275	345	436	549	693	874	1104	1391	1642	1971	2304	2634	3277				
P60A0050A4	5	460	3.7	30		15	25	621	988	1576	2496	3883																	
P60A0075A4	7-1/2		5.5	40		25	35	440	699	1116	1767	2749	4383	5510															
P60A0100A4	10		7.5	50		30	40	336	534	852	1349	2099	3346	4207	5312														
P60A0150A4	15		11.0	70	45	60	216	344	548	868	1351	2153	2707	3418	4306	5436													
P60A0200A4	20		15.0	90	50	80	169	269	429	679	1057	1684	2118	2674	3369	4253	5365												
P60A0250A4	25		19.0	110	70	100			343	543	844	1346	1692	2137	2691	3397	4286	5411											
P60A0300A4	30		22.0	150	80	110			283	448	697	1110	1396	1763	2221	2803	3537	4465											
P60A0400A4	40		30.0	175	100	150				341	530	845	1062	1342	1690	2134	2692	3398	4281	5054									
P60A0500A4	50		37.0	225	150	175					414	659	829	1047	1319	1665	2100	2652	3341	3944	4734	5534							
P60A0050A5	5		575	3.7	25	15	20	955	1520	2424	3839																		
P60A0075A5	7-1/2	5.5		30	20	25	668	1062	1694	2683	4175																		
P60A0100A5	10	7.5		40	25	30	526	837	1335	2115	3291	5246																	
P60A0150A5	15	11.0		60	30	45	363	578	921	1459	2271	3620	4551																
P60A0200A5	20	15.0		80	45	60	262	417	665	1053	1638	2612	3284	4147	5224														
P60A0250A5	25	19.0		90	60	80	209	333	531	840	1307	2084	2620	3309	4169	5262													
P60A0300A5	30	22.0		110	70	90		282	450	713	1109	1769	2224	2808	3537	4465													
P60A0400A5	40	30.0		150	90	125			333	528	821	1309	1645	2078	2618	3304	4169	5262											
P80A0500A4	50	460		37.0	225	125	175					420	669	841	1062	1338	1690	2132	2691	3390	4002	4805	5616						
P80A0600A4	60			45.0	250	150	200							556	700	883	1113	1405	1772	2237	2819	3328	3995	4670	5339				
P80A0750A4	75		56.0	350	200	250								571	721	909	1147	1447	1827	2302	2717	3262	3813	4359	5424				
P80A1000A4	100		75.0	400	250	350										678	856	1080	1364	1718	2029	2435	2847	3255	4049				
P80A1250A4	125		93.0	600	350	450											665	839	1059	1334	1575	1891	2211	2528	3145				
P80A1500A4	150		112.0	700	400	500												692	873	1100	1299	1559	1823	2084	2593				
P80A0500A5	50		575	37.0	225	125	175				423	658	1049	1319	1666	2098	2649	3342	4219	5315									
P80A0600A5	60			45.0	250	150	200						547	872	1096	1384	1744	2201	2777	3506	4417	5214							
P80A0750A5	75			56.0	350	200	250							703	884	1117	1407	1776	2241	2829	3564	4207	5050	5904					
P80A1000A5	100			75.0	400	250	350								683	862	1086	1371	1730	2183	2751	3248	3899	4557	5210				
P80A1250A5	125	93.0		600	350	450										837	1056	1332	1682	2119	2502	3003	3510	4013	4993				
P80A1500A5	150	112.0		700	400	500											878	1108	1398	1762	2080	2497	2919	3337	4152				

SECTION 6: PENTEK 6" AND 8" SUBMERSIBLE MOTORS

CABLE SELECTION: 8" MOTOR - COPPER CABLE SIZE - FROM SERVICE ENTRANCE TO MOTOR (FEET) - INDIVIDUAL CONDUCTORS

60°C

VOLTS /HZ	HP	KW	AWG												MCM					
			14	12	10	8	6	4	3	2	1	0	00	000	0000	250	300	350	400	500
460V 60Hz	50	37	-	-	-	-	363	579	728	920	1159	1463	1846	2330	2935	3465	4160	4863		
	60	45	-	-	-	-	-	482	606	765	964	1216	1534	1937	2441	2881	3459	4043	4623	
	75	56	-	-	-	-	-	-	495	625	787	993	1253	1582	1993	2353	2824	3301	3774	4696
	100	75	-	-	-	-	-	-	-	-	587	741	935	1181	1488	1756	2108	2465	2818	3506
	125	93	-	-	-	-	-	-	-	-	-	576	726	917	1155	1364	1637	1914	2188	2723
	150	112	-	-	-	-	-	-	-	-	-	-	599	756	953	1125	1350	1578	1804	2245
575V 60Hz	50	37	-	-	-	360	560	893	1123	1418	1787	2255	2845	3592	4525					
	60	45	-	-	-	-	480	766	963	1216	1531	1933	2439	3079	3879	4579				
	75	56	-	-	-	-	-	609	766	967	1218	1538	1940	2449	3085	3642	4373			
	100	75	-	-	-	-	-	-	586	740	932	1177	1484	1874	2361	2787	3346	3911	4472	
	125	93	-	-	-	-	-	-	-	-	724	914	1153	1456	1835	2166	2600	3039	3475	4323
	150	112	-	-	-	-	-	-	-	-	-	760	959	1211	1525	1801	2162	2527	2889	3595

Lengths only meet the US National Electrical Code ampacity requirements for individual conductors rated to 60°C in free air or water, NOT in magnetic enclosures, conduit, or direct buried. Refer to NEC Table 310.15(B)(17) for more information.

MCM equals circular mills of the wire x 1000

CABLE SELECTION: 8" MOTOR - COPPER CABLE SIZE - FROM SERVICE ENTRANCE TO MOTOR (FEET) - INDIVIDUAL CONDUCTORS

75°C

VOLTS /HZ	HP	KW	AWG												MCM					
			14	12	10	8	6	4	3	2	1	0	00	000	0000	250	300	350	400	500
460V 60Hz	50	37	-	-	-	-	363	579	728	920	1159	1463	1846	2330	2935	3465	4160	4863		
	60	45	-	-	-	-	-	482	606	765	964	1216	1534	1937	2441	2881	3459	4043	4623	
	75	56	-	-	-	-	-	-	495	625	787	993	1253	1582	1993	2353	2824	3301	3774	4696
	100	75	-	-	-	-	-	-	-	-	587	741	935	1181	1488	1756	2108	2465	2818	3506
	125	93	-	-	-	-	-	-	-	-	-	576	726	917	1155	1364	1637	1914	2188	2723
	150	112	-	-	-	-	-	-	-	-	-	-	599	756	953	1125	1350	1578	1804	2245
575V 60Hz	50	37	-	-	-	366	570	908	1142	1442	1817	2293	2893	3653	4602					
	60	45	-	-	-	-	474	755	949	1198	1510	1906	2404	3035	3824	4515				
	75	56	-	-	-	-	-	609	766	967	1218	1538	1940	2449	3085	3642	4373	5111		
	100	75	-	-	-	-	-	-	591	746	940	1187	1497	1890	2382	2812	3375	3946	4511	
	125	93	-	-	-	-	-	-	-	-	724	914	1153	1456	1835	2166	2600	3039	3475	4323
	150	112	-	-	-	-	-	-	-	-	-	760	959	1211	1525	1801	2162	2527	2889	3595

Lengths only meet the US National Electrical Code ampacity requirements for individual conductors rated to 75°C in free air or water, NOT in magnetic enclosures, conduit, or direct buried. Refer to NEC Table 310.15(B)(17) for more information.

MCM equals circular mills of the wire x 1000

SECTION 6: PENTEK 6" AND 8" SUBMERSIBLE MOTORS

CABLE SELECTION: 8" MOTOR - COPPER CABLE SIZE - FROM SERVICE ENTRANCE TO MOTOR (FEET) - JACKETED CONDUCTORS

60°C

VOLTS /HZ	HP	KW	AWG													MCM				
			14	12	10	8	6	4	3	2	1	0	00	000	0000	250	300	350	400	500
460V 60Hz	50	37	-	-	-	-	-	-	728	920	1159	1463	1846	2330	2935	3465	4160	4863		
	60	45	-	-	-	-	-	-	-	765	964	1216	1534	1937	2441	2881	3459	4043	4623	
	75	56	-	-	-	-	-	-	-	-	787	993	1253	1582	1993	2353	2824	3301	3774	4696
	100	75	-	-	-	-	-	-	-	-	-	-	935	1181	1488	1756	2108	2465	2818	3506
	125	93	-	-	-	-	-	-	-	-	-	-	-	-	1155	1364	1637	1914	2188	2723
	150	112	-	-	-	-	-	-	-	-	-	-	-	-	-	-	1350	1578	1804	2245
575V 60Hz	50	37	-	-	-	-	-	893	1123	1418	1787	2255	2845	3592	4525					
	60	45	-	-	-	-	-	963	1216	1531	1933	2439	3079	3879	4579					
	75	56	-	-	-	-	-	-	967	1218	1538	1940	2449	3085	3642	4373				
	100	75	-	-	-	-	-	-	-	-	-	1177	1484	1874	2361	2787	3346	3911	4472	
	125	93	-	-	-	-	-	-	-	-	-	-	-	1456	1835	2166	2600	3039	3475	4323
	150	112	-	-	-	-	-	-	-	-	-	-	-	-	1525	1801	2162	2527	2889	3595

Lengths meet the US National Electrical Code ampacity requirements for individual conductors or jacketed rated 60°C cable and can be in conduit or direct buried. Flat molded and web/ribbon cable are considered jacketed cable. Refer to NEC Table 310.15(B)(16) for more information

MCM equals circular mills of the wire x 1000

CABLE SELECTION: 8" MOTOR - COPPER CABLE SIZE - FROM SERVICE ENTRANCE TO MOTOR (FEET) - JACKETED CONDUCTORS

75°C

VOLTS /HZ	HP	KW	AWG													MCM				
			14	12	10	8	6	4	3	2	1	0	00	000	0000	250	300	350	400	500
460V 60Hz	50	37	-	-	-	-	-	579	728	920	1159	1463	1846	2330	2935	3465	4160	4863		
	60	45	-	-	-	-	-	-	606	765	964	1216	1534	1937	2441	2881	3459	4043	4623	
	75	56	-	-	-	-	-	-	-	625	787	993	1253	1582	1993	2353	2824	3301	3774	4696
	100	75	-	-	-	-	-	-	-	-	-	741	935	1181	1488	1756	2108	2465	2818	3506
	125	93	-	-	-	-	-	-	-	-	-	-	-	917	1155	1364	1637	1914	2188	2723
	150	112	-	-	-	-	-	-	-	-	-	-	-	-	953	1125	1350	1578	1804	2245
575V 60Hz	50	37	-	-	-	-	560	893	1123	1418	1787	2255	2845	3592	4525					
	60	45	-	-	-	-	766	963	1216	1531	1933	2439	3079	3879	4579					
	75	56	-	-	-	-	-	766	967	1218	1538	1940	2449	3085	3642	4373				
	100	75	-	-	-	-	-	-	740	932	1177	1484	1874	2361	2787	3346	3911	4472		
	125	93	-	-	-	-	-	-	-	-	-	-	1153	1456	1835	2166	2600	3039	3475	4323
	150	112	-	-	-	-	-	-	-	-	-	-	-	1211	1525	1801	2162	2527	2889	3595

Lengths meet the US National Electrical Code ampacity requirements for individual conductors or jacketed rated 60°C cable and can be in conduit or direct buried. Flat molded and web/ribbon cable are considered jacketed cable. Refer to NEC Table 310.15(B)(16) for more information

MCM equals circular mills of the wire x 1000

SECTION 6: PENTEK 6" AND 8" SUBMERSIBLE MOTORS

6.7 OVERLOAD PROTECTION

Submersible motors must have Class 10 overload protection that will disconnect the power within 10 seconds in the case of a locked rotor. To accomplish this, fixed-heater overloads are used. Refer to Section 10 for appropriate heaters. The chart is based upon total line amps. Divide the motor amps by 1.732 when using a 6-lead motor with a Y-Delta Starter. **NOTE:** General Electric® overload heaters are only usable with General Electric overload relays. Do not adjust relays to exceed nameplate amps.

6.8 MOTOR COOLING

Pentek 6" motors are designed for minimum water flow of 0.5 ft./sec. past the motor. Maximum water temperature is 95° F (35° C).

6" MOTORS: MINIMUM COOLING WATER FLOW

I.D of casing	Flow (GPM) required
6	9
7	25
8	40
10	85
12	140
14	200
16	280

If the flow is less than specified, a flow-inducer sleeve can be installed. This will act like a smaller casing size, and force flow around the motor to aid cooling. Always use a flow-inducer sleeve when the pump is in open water.

6.9 HEAD LOSS IN CASING

Use the chart below to account for the head loss around the pump.

HEAD LOSS IN FEET FOR FLOW PAST MOTOR

6" MOTORS		CASING INSIDE DIAMETER		
		6"	7"	8"
GPM	100	1.7		
	150	3.7		
	200	6.3	0.5	
	250	9.6	0.8	
	300	13.6	1.2	0.2
	400	23.7	2.0	0.4
	500		3.1	0.7
	600		4.4	1.0

6.10 STARTING FREQUENCY

To extend the life of the pump motor and control, limit the number of starts to 100 per 24 hours. If higher starting frequencies are necessary, consult your factory. To prevent overheating, run motor for a minimum of two minutes. For starting frequency, refer to Section 5.10.

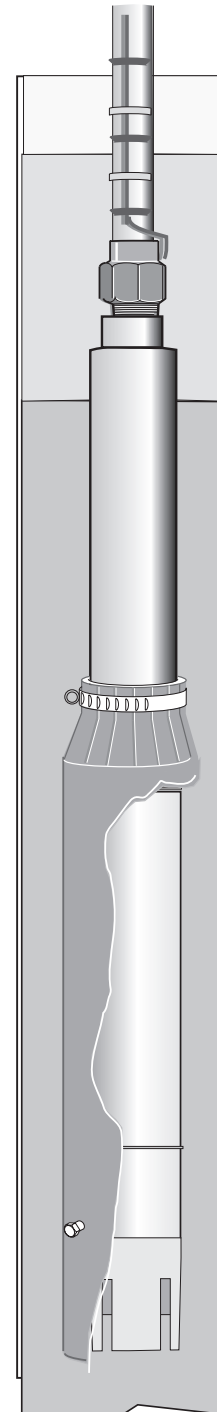

Figure 6-5

SECTION 6: PENTEK 6" AND 8" SUBMERSIBLE MOTORS

6.11 TROUBLESHOOTING

PROBLEM	POSSIBLE CAUSES	SOLUTION
Motor does not start, but does not blow fuses or trip circuit breaker.	Defective fuses or circuit breakers. Loose or corroded terminals. Damaged or defective connections. No incoming power.	Replace fuses or circuit breakers. Clean and tighten connections and motor lead terminals. Repair or replace connections. Contact power company.
Motor starts, but fuses blow or circuit breakers trip.	Wrong voltage. Incorrect fuses or relay. Incorrect connections. Locked rotor or pump. Insufficient insulation on motor cables.	Make sure that nameplate rated voltage matches nominal power supply, and that actual supply voltage is within $\pm 10\%$ of nameplate voltage. Install correct fuses or relay. Re-connect motor wires correctly. Make sure that motor is at least 10ft above bottom of well, check well for sand. Install new motor cables; recheck resistance with Megohmmeter.
Motor starts and runs, then blows fuse or trips circuit breaker.	Incoming voltage more than 10% high or low sand in well.	Confirm high or low voltage in motor cable, consult power company. Pull the pump and clean the well.
Motor does not start, but fuse blows or circuit breaker trips.	Locked rotor or pump.	Check for sand in well. Make sure that motor is at least 10ft above the bottom of the well. Pull pump and check for mechanical obstruction in the pump and for free rotation of the motor.

SECTION 7: HITACHI® 6" AND LARGER SUBMERSIBLE MOTORS

7.1 MOTOR INSPECTION

The following conditions are stated to provide the owner with a list of criteria for maximum motor life and to assure motor warranty.

1. Maximum water temperature:
 - ◆ 35°C (95°F): 6" (5-40HP) motors.
 - ◆ 25°C (77°F): 6" (50,60HP), 8", 10", 12" and 14" motors.
2. PH content of the water between: 6.5-8.
3. Maximum chlorine content: 500 PPM.
 - ◆ Maximum Sulfuric acid iron content: 15 PPM.
 - ◆ Maximum Fluorine content: 0.8 PPM.
 - ◆ Maximum Electric conductivity: 118 µMHO/INCH.
4. Maximum sand content: 50 PPM.
5. See Table 7-13 for proper approved three phase overload protection.
6. See Section 7.6 for proper fusing for motor circuit protection.
7. Proper line voltage during running conditions at motor lead terminal. (Voltage drop of cable should be considered by user.):
 - ◆ 60Hz: 460V, 230V ±10%.
 - ◆ 50Hz: 380V ±10%.
 - ◆ Combination of voltage and frequency variation: ±10% (sum of absolute values of voltage and frequency).
 - ◆ Current unbalance between legs should not exceed 5% of the average.
8. Proper sizing of motor (current, thrust, voltage, etc.) and a 10 feet clearance from the bottom of the well are required.
9. In the case of horizontal installation, the motor is to be rigidly aligned with the pump and firmly mounted to prevent any load on the shaft and bearings and to avoid any damaging vibrations to the motor.
10. The motor must always be immersed in water so that a flow velocity of cooling water at a rate of 0.5 feet per second flows past any and all parts of the motor. The motor will not operate in mud or sand.
11. The power cables shall be sized large enough so that at rated current there will be less than a 5% voltage drop. See Table C. Cables must be waterproof submersible type.
12. For 3Ø motor a balanced and properly sized transformer bank shall be provided. Improper electrical supply (for example, phase converter, V-connection transformer, etc.) or connections will void the warranty.
13. Single-phase protection is recommended for protection of the installation. Any failure due to single phasing of the incoming voltage causing the motor to fail will void the warranty.
14. Surge suppressors are recommended in the interest of protecting the control panel, as well as the insulation system of the motor. Any motor failure due to lightning or other Acts of God will void the warranty.
15. Provide waterproof insulation splices between all lead wires and well cables.
16. In the event that a reduced voltage starter is used to start the motor, the following should be verified:
 - ◆ Correct quick trip, class 10 or better, ambient compensated overloads are incorporated.
 - ◆ Proper short circuit protection is utilized.
 - ◆ The torque required by the motor and pump package is attainable by this type starter.
 - ◆ The lead arrangement of the motor is acceptable with the proposed starter load connections.
 - ◆ Verify that if any time delay relays are used in switching contactors in and out, that the time settings do not exceed 2 seconds; this could damage the motor.
 - ◆ If a manual auto transformer starter is used, voltage should be minimum 60% of rated voltage, and switched to "Run" condition within 2 seconds. Double check Table B and C for correct protection.
17. Single-Phase Motors (5-15HP): Proper connections and correct capacitors and relays are necessary for single-phase motor starting and running. Connection diagram: Fig. 1. Performance and recommendable capacitors: See Table D.

SECTION 7: HITACHI® 6" AND LARGER SUBMERSIBLE MOTORS

7.2 TESTING

1. Do not use lead wires to pull, lift or handle the motor. The lead wires should be protected during storage, handling, moving and installation of the motor.
2. Inspect the motor to determine that it is the correct HP, voltage, and size for the job and that there is no shipping damage.
3. The factory-installed water in the motor is supplied with anti-freeze capable of temperatures to 0°C (-22°F). Do not install, transport or store below these temperatures. If storage is necessary below these temperatures, drain the water from the motor.
4. After long periods of idleness and on all new installations, check the electrical resistance and megger the motor with lead wires connected: see table A. Prior to installation, the motor should have an insulation value of at least 50 megohms. After installation, motor and power cable should have a minimum insulation value of 1 megohm. If minimum values are not obtained, contact factory.
5. Verify motor is filled with clean water before installing. The warranty is void if this is not done. Also check the tightness of all water filling and drain plugs, mounting bolts and cable connections.
6. Do not hammer the shaft, coupling or slinger since this may damage the thrust bearing. Check the rotation of the motor by hand to insure that it turns freely.
7. Do not drop the bottom end of the motor in the dirt or mud since this may plug up the diaphragm opening.
8. If motor is to be installed horizontal, make sure that the lead wires are at the 12 o'clock position when facing the motor shaft (in horizontal position).

There are no bearings that need oil or grease. The motor, being inaccessible, should be monitored through its electrical connections.

- ◆ Measure and record operating current and voltage.
- ◆ Measure and record the motor insulation resistance. Any resistance of less than 50 megohm (5,000,000) for a new motor should be evaluated or checked further by a qualified service shop.
- ◆ Lightning arrestors and/or surge capacitors will help prevent damage to the control box, cables, and motor.
- ◆ Single-phase protection will help in preventing motor failure due to adverse incoming primary power.
- ◆ Based on the values obtained in A and B above and the output flow rates and pressures of the pump, a complete picture of total performance can be obtained. This can be used to determine any pump and motor maintenance and overhauling which might be required.
- ◆ If the motor is to be stored, protect the unit from freezing by storing in an area with a temperature higher than -30°C (-22° F).

7.3 STORAGE AND DRAIN FILL INSTRUCTIONS

1. After energizing the motor, check the flow and pressure of the pump to make sure that the motor is rotating in the correct direction. To correct a wrong rotation, switch any two of the three cable connections (three-phase motor only).
2. When starting the pump for the first time, inspect the water for sand. If sand appears, then continue to pump till the water clears up; otherwise, sand will accumulate in the pump stages and will bind or freeze the moving parts if water is allowed to flow back down the well.
3. During testing or checking rotation (such as "humping" or "inching") the number of "starts" should be limited to 3, followed by a full 15 minute cooling-off period before any additional "starts" are attempted. Depending on the depth of the well and/or method of checking, these rotational checks or "starts" may actually be full-fledged starts. If this is the case, then a full cooling-off period of 15 minutes is required between this type of start.
4. For automatic (pilot device) operation, the motor should be allowed to cool for 15 minutes between starts.
5. Input voltage, current and insulation resistance values should be recorded throughout the life of the installation and should be used as a form of preventive maintenance.

SECTION 7: HITACHI® 6" AND LARGER SUBMERSIBLE MOTORS

7.4 MOTOR SPECIFICATIONS

TABLE A. RESISTANCE DATA SINGLE PHASE 2 POLE 230V/60HZ

MOTOR SIZE AND TYPE	HP	RESISTANCE (Ω)		
		R - Y	B - Y	R - B
6", C	5	2.172	0.512	2.627
	7.5	1.401	0.400	1.774
	10	1.052	0.316	1.310
	15	0.678	0.230	0.850

TABLE B. THREE PHASE 2 POLE

MOTOR SIZE AND TYPE	HP	VOLT	RESISTANCE (Ω)	
6", C	5	230	.806	
	5	460	3.050	
	7.5	230	0.651	
	7.5	460	2.430	
	10	230	0.448	
	10	460	1.619	
	15	230	0.312	
	15	460	1.074	
	20	230	0.258	
	20	460	0.861	
	25	230	0.210	
	25	460	0.666	
	30	230	0.166	
	30	460	0.554	
	40		0.446	
	50		0.388	
	60		0.388	
	8", W		40	0.372
			50	0.331
			60	0.278
75			0.218	
100		0.164		
10", W	125	0.132		
	150	0.115		
	175	0.121		
12", W	200	0.0929		
	250	0.0776		
12", W	300	0.0386		

TABLE C. THREE PHASE 4 POLE

MOTOR SIZE AND TYPE	HP	VOLT	RESISTANCE (Ω)
8", W	7.5	230	.564
	7.5	460	2.178
	10	230	0.564
	10	460	2.178
	15	230	0.399
	15	460	1.519
	20	230	0.399
	20	460	1.519
	25	230	0.242
	25	460	0.888
	30	230	0.242
	30	460	0.888
10", W	40	230	0.408
	50	460	0.408
	60		0.288
	75		0.257
	100		0.171
	125		0.171
150	0.138		
12", W	175	0.119	
	200	0.0826	
14", W	250	0.0552	
	300	0.0517	

Values are for normal temp. 68°(20°) with motor lead wires.

LEAD WIRE COLOR

- R: Red
- Y: Yellow
- B: Black
- G: Green (6" only)

MOTOR TYPE

- C: CANNED
- W: WATER TYPE

SECTION 7: HITACHI® 6" AND LARGER SUBMERSIBLE MOTORS

7.4 MOTOR SPECIFICATIONS

MATERIALS OF CONSTRUCTION

PARTS	MATERIALS
Motor Sleeve	Stainless steel construction
Castings	Baked epoxy-coated gray iron
Fasteners	Stainless steel
Shaft	NEMA splined stainless steel
Flange	NEMA standard type
Rotor	Double epoxy-coated
Thrust Bearings	Kingsbury-type 420 stainless steel
Mechanical Seal	Nitrile rubber (NBR), grease packed
Diaphragm	Nitrile rubber
Sand Cap	Polyurethane
Sand Slinger	Stainless steel
Lead Wire (or Cable)	Double-insulated, heat and water-resistant, 167°F/75°C, 600V

MOTOR DIMENSIONS

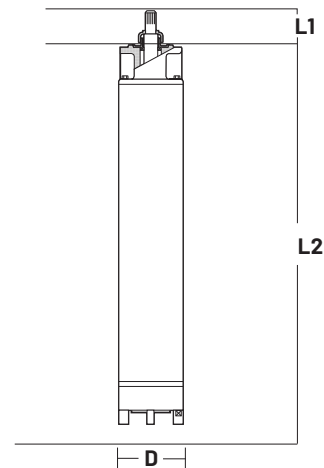

DIAMETER	HP	KW	VOLTS	PH	HZ	RPM	CATALOG NUMBER	SERVICE FACTOR	WINDING RESISTANCE (OHMS)	RATED INPUT AMPS	SERVICE FACTOR INPUT AMPS	SHAFT EXTENSION (L1)	LENGTH (L2)	DIAMETER (D)	THRUST CAPACITY	WEIGHT
6	5	3.7	200	3	60	3600	6HIT2-5-8	1.15		17.5	19.5	2.87"	22.95"	5.5"	3,500	95
6	5	3.7	230	1	60	3600	6HIT2-5-1	1.15	R-Y, B-Y, R-B, 2.172, 0.512, 2.627	24	27.5	2.87"	26.97"	5.5"	3,500	110
6	5	3.7	230	3	60	3600	6HIT2-5-2	1.15	0.806	15	17	2.87"	22.95"	5.5"	3,500	95
6	5	3.7	460	3	60	3600	6HIT2-5-4	1.15	3.05	7.5	8.5	2.87"	22.95"	5.5"	3,500	95
6	7.5	5.5	200	3	60	3600	6HIT2-7-8	1.15		25.4	28.5	2.87"	24.80"	5.5"	3,500	99
6	7.5	5.5	230	1	60	3600	6HIT2-7-1	1.15	R-Y, B-Y, R-B, 1.401, 0.400, 1.774	36	41	2.87"	29.92"	5.5"	3,500	128
6	7.5	5.5	230	3	60	3600	6HIT2-7-2	1.15	0.651	22	26	2.87"	24.80"	5.5"	3,500	99
6	7.5	5.5	460	3	60	3600	6HIT2-7-4	1.15	2.43	11	13	2.87"	24.80"	5.5"	3,500	99
6	10	7.5	200	3	60	3600	6HIT2-10-8	1.15		33.3	37.2	2.87"	26.97"	5.5"	3,500	110
6	10	7.5	230	1	60	3600	6HIT2-10-1	1.15	R-Y, B-Y, R-B, 1.052, 0.316, 1.310	50	58	2.87"	29.92"	5.5"	3,500	128
6	10	7.5	230	3	60	3600	6HIT2-10-2	1.15	0.448	29	33	2.87"	26.97"	5.5"	3,500	110
6	10	7.5	460	3	60	3600	6HIT2-10-4	1.15	1.619	14.5	16.5	2.87"	26.97"	5.5"	3,500	110
6	15	11	200	3	60	3600	6HIT2-15-8	1.15		47.4	53.5	2.87"	29.92"	5.5"	3,500	128
6	15	11	230	1	60	3600	6HIT2-15-1	1.15	R-Y, B-Y, R-B, 0.678, 0.230, 0.850	72	85	2.87"	33.46"	5.5"	3,500	148
6	15	11	230	3	60	3600	6HIT2-15-2	1.15	0.312	42	46	2.87"	29.92"	5.5"	3,500	128
6	15	11	460	3	60	3600	6HIT2-15-4	1.15	1.074	21	23	2.87"	29.92"	5.5"	3,500	128
6	20	15	200	3	60	3600	6HIT2-20-8	1.15		61.2	69.5	2.87"	31.5"	5.5"	3,500	137
6	20	15	230	3	60	3600	6HIT2-20-2	1.15	0.258	54	60	2.87"	31.5"	5.5"	3,500	137
6	20	15	460	3	60	3600	6HIT2-20-4	1.15	0.861	27	30	2.87"	31.5"	5.5"	3,500	137
6	25	18.5	200	3	60	3600	6HIT2-25-8	1.15		77.3	87.5	2.87"	36.22"	5.5"	3,500	161
6	25	18.5	230	3	60	3600	6HIT2-25-2	1.15	0.21	68	76	2.87"	36.22"	5.5"	3,500	161
6	25	18.5	460	3	60	3600	6HIT2-25-4	1.15	0.666	34	38	2.87"	36.22"	5.5"	3,500	161
6	30	22	200	3	60	3600	6HIT2-30-8	1.15		91.8	104	2.87"	38.19"	5.5"	3,500	176
6	30	22	230	3	60	3600	6HIT2-30-2	1.15	0.166	82	94	2.87"	39.19"	5.5"	3,500	176
6	30	22	460	3	60	3600	6HIT2-30-4	1.15	0.554	41	47	2.87"	38.19"	5.5"	3,500	176
6	40	30	460	3	60	3600	6HIT2-40-4	1.15	0.358	56	61	2.87"	40.55"	5.5"	5,000	187



HITACHI CONTROL BOXES

Type 1 NEMA Enclosure
 In-Panel Circuit Breaker
 Magnetic Contactor
 Terminal Blocks for External Controls
 UL Recognized

HP	KW	PH	VOLTS	CATALOG NUMBER
5	3.7	1	230	HIT-5CBD
7.5	5.5	1	230	HIT-7.5CBD
10	7.5	1	230	HIT-10CBD
15	11	1	230	HIT-15CBD

SECTION 7: HITACHI® 6" AND LARGER SUBMERSIBLE MOTORS

7.4 MOTOR SPECIFICATIONS

MATERIALS OF CONSTRUCTION

PARTS	MATERIALS
Housing	Baked epoxy-coated gray iron
Fasteners	Stainless steel
Shaft	Splined or keyed stainless steel
Rotor	Double epoxy-coated
Thrust Bearings	Kingsbury-type 420 stainless steel
Mechanical Seal	Nitrile rubber (NBR), grease packed
Diaphragm	Nitrile rubber
Sand Slinger	Baked epoxy-coated gray iron
Lead Wire (or Cable)	Double-insulated, heat and water-resistant, 167°F/75°C, 600V

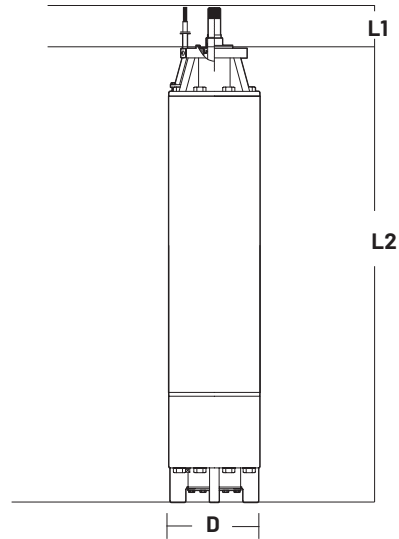

MOTOR DIAMETER (IN)	HP	KW	VOLTS	PH	HZ	RPM	CATALOG NUMBER	SERVICE FACTOR	WINDING RESISTANCE (OHMS)	RATED INPUT AMPS	SERVICE FACTOR INPUT AMPS	SHAFT EXTENSION (L1)	LENGTH (L2)	DIAMETER (D)	THRUST CAPACITY (LBS)	WEIGHT (LBS)
8*	50	37	460	3	60	3600	86HIT2-50-4	1.15	0.331	65	73	2.875	45.28	5.5	5000; **10000	423
8*	60	45	460	3	60	3600	86HIT2-60-4	1.15	0.278	80	90	2.875	48.03	5.5	5000; **10000	478
8	7.5	5.5	460	3	60	1800	8HIT4-7-4	1.15	2.178	13	14	4.0	37.40	7.52	10000	364
8	10	7.5	460	3	60	1800	8HIT4-10-4	1.15	2.178	16	18	4.0	37.40	7.52	10000	364
8	15	11	460	3	60	1800	8HIT4-15-4	1.15	1.519	23	26	4.0	41.34	7.52	10000	386
8	20	15	460	3	60	1800	8HIT4-20-4	1.15	1.519	29	33	4.0	41.34	7.52	10000	386
8	25	18.5	460	3	60	1800	8HIT4-25-4	1.15	0.888	38	43	4.0	44.09	7.52	10000	408
8	30	22	460	3	60	1800	8HIT4-30-4	1.15	0.888	44	50	4.0	44.09	7.52	10000	408
8	40	30	460	3	60	3600	8HIT2-40-4	1.15	0.372	56	63	4.0	44.09	7.52	10000	397
8	50	37	460	3	60	3600	8HIT2-50-4	1.15	0.331	65	73	4.0	46.44	7.52	10000	430
8	60	45	460	3	60	3600	8HIT2-60-4	1.15	0.278	80	90	4.0	49.19	7.52	10000	485
8	75	55	460	3	60	3600	8HIT2-75-4	1.15	0.218	96	109	4.0	53.15	7.52	10000	540
8	100	75	460	3	60	3600	8HIT2-100-4	1.15	0.164	127	145	4.0	58.27	7.52	10000	595
8	125	90	460	3	60	3600	8HIT2-125-4	1.15	0.132	161	180	4.0	66.14	7.52	10000	683
8	150	110	460	3	60	3600	8HIT2-150-4	1.15	0.115	197	220	4.0	70.08	7.52	10000	750
10	40	30	460	3	60	1800	10HIT4-40-4	1.15	0.408	62	71	4.0	49.21	8.52	10000	584
10	50	37	460	3	60	1800	10HIT4-50-4	1.15	0.408	73	83	4.0	49.21	8.52	10000	584
10	60	45	460	3	60	1800	10HIT4-60-4	1.15	0.288	91	104	4.0	59.84	8.52	10000	717
10	75	55	460	3	60	1800	10HIT4-75-4	1.15	0.257	106	121	4.0	59.84	8.52	10000	717
10	100	75	460	3	60	1800	10HIT4-100-4	1.15	0.171	145	166	5.0	69.68	8.52	10000	882
10	125	90	460	3	60	1800	10HIT4-125-4	1.15	0.171	175	200	5.0	69.68	8.52	10000	882
10	200	150	460	3	60	3600	10HIT2-200-4	1.15	0.0929	235	270	5.0	69.68	8.52	10000	915
10	250	185	460	3	60	3600	10HIT2-250-4	1.15	0.0776	295	340	5.0	79.53	8.52	10000	1047
12	150	110	460	3	60	1800	12HIT4-150-4	1.15	0.138	190	218	5.0	56.3	10.53	10000	1047
12	200	150	460	3	60	1800	12HIT4-200-4	1.15	0.0826	255	293	5.0	68.11	10.53	10000	1367
12	300	225	460	3	60	3600	12HIT2-300-4	1.15	0.0386	350	396	5.0	78.75	10.53	10000	1631
14	250	185	460	3	60	1800	14HIT4-250-4	1.15	0.0552	305	350	5.0	68.31	12.6	10000	1830
14	300	225	460	3	60	1800	14HIT4-300-4	1.15	0.0517	370	425	5.0	76.18	12.6	10000	2094

*Motor is 8" diameter, but constructed to operate with a 6" liquid end.

** 8" motors with 6" flange when using stainless steel bolts have a thrust rating of 5,000 lbs. A thrust value of 10,000 lbs. can be obtained using grade-8 heat-treated stainless steel bolts.

SECTION 7: HITACHI® 6" AND LARGER SUBMERSIBLE MOTORS

7.5 MOTOR DIMENSIONS

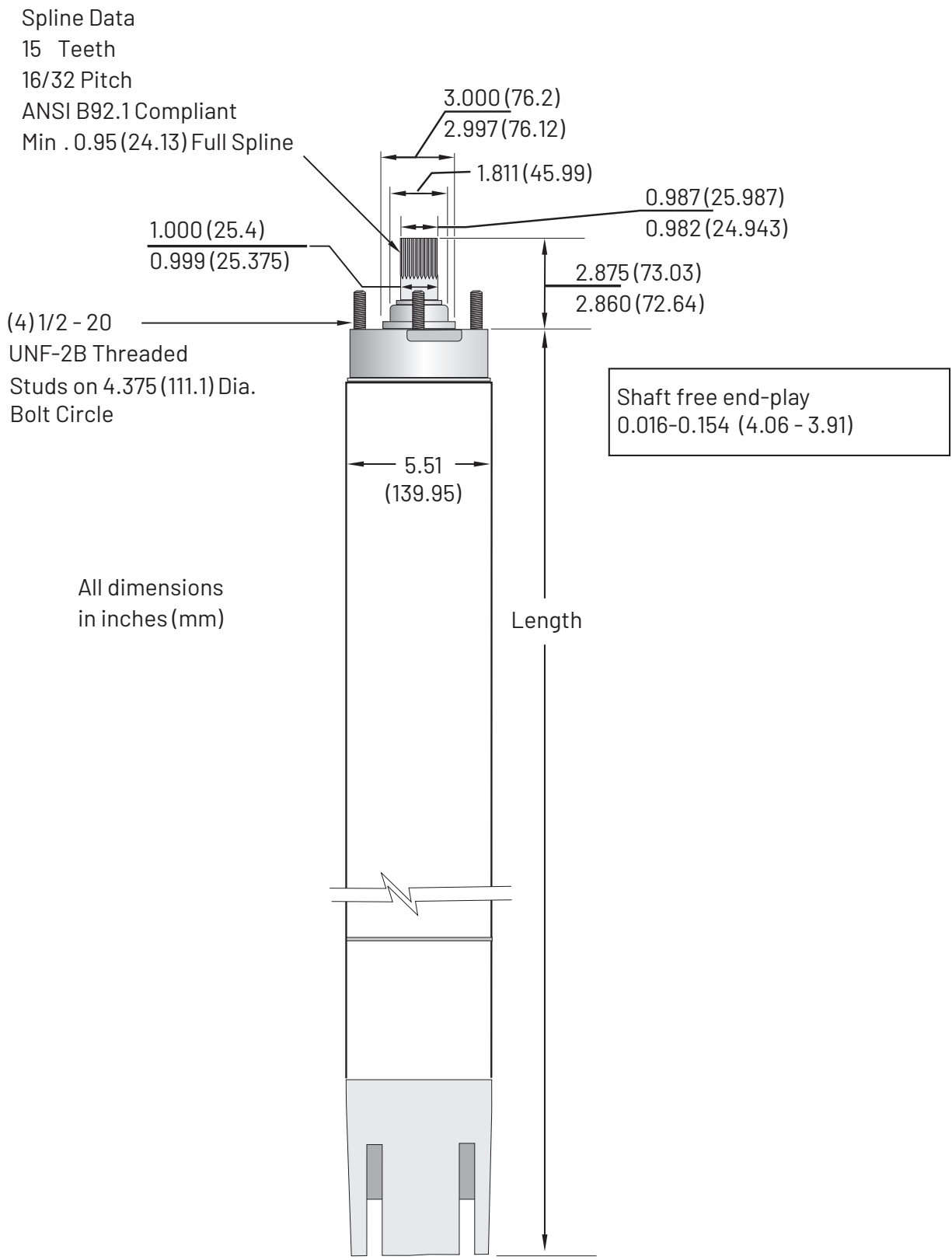

SECTION 7: HITACHI® 6" AND LARGER SUBMERSIBLE MOTORS

7.6 MOTOR FUSE SIZING AND CABLE SELECTION

CABLE SELECTION: COPPER CABLE SIZE - FROM MAIN BREAKER PANEL TO MOTOR (IN FEET)

60°

MOTOR				AWG														MCM				
VOLTS /HZ	HP	KW	FUSE		14	12	10	8	6	4	3	2	1	0	00	000	0000	250	300	350	400	500
			STD	DUAL ELEMENT																		
THREE PHASE																						
230 V 60 Hz	5	4	45	25	149	237	378	598	931	1484	1865	2356	2967	3746	4726	5966	7516	8873	-	-	-	-
	8	6	60	35	-	-	247	391	609	970	1220	1540	1940	2449	3090	3901	4914	5802	6965	8142	9308	-
	10	8	80	45	-	-	-	308	479	764	961	1213	1529	1930	2434	3073	3872	4571	5488	6415	7334	9125
	15	11	125	70	-	-	-	221	344	548	689	871	1097	1384	1746	2205	2778	3279	3937	4602	5261	6546
	20	15	150	90	-	-	-	-	264	420	528	667	841	1061	1339	1690	2130	2514	3018	3528	4034	5019
	25	19	200	100	-	-	-	-	-	332	417	527	664	838	1057	1334	1681	1985	2383	2785	3184	3962
	30	22	225	125	-	-	-	-	-	-	337	426	537	677	855	1079	1359	1605	1926	2252	2575	3203
	40*	30	300	175	-	-	-	-	-	-	-	328	413	522	659	831	1047	1236	1484	1735	1984	2468
460 V 60 Hz	5	4	20	10	595	947	1511	2393	3723	5935	7461	9422	-	-	-	-	-	-	-	-	-	-
	8	6	30	15	389	619	988	1564	2434	3880	4878	6161	7761	9797	-	-	-	-	-	-	-	-
	10	8	40	20	307	488	778	1233	1918	3057	3844	4854	6115	7719	9738	-	-	-	-	-	-	-
	15	11	60	30	-	350	558	884	1376	2193	2757	3482	4387	5537	6986	8819	-	-	-	-	-	-
	20	15	80	45	-	-	428	678	1055	1682	2114	2670	3363	4245	5356	6761	8518	-	-	-	-	-
	25	19	100	50	-	-	-	535	833	1328	1669	2108	2655	3351	4228	5338	6725	7939	9531	-	-	-
	30	22	110	60	-	-	-	433	673	1073	1349	1704	2147	2710	3419	4316	5437	6419	7706	9008	-	-
	40	30	150	80	-	-	-	-	519	827	1040	1313	1654	2088	2634	3325	4189	4946	5937	6940	7935	9873
	40*	30	150	80	-	-	-	-	502	801	1007	1271	1601	2022	2550	3220	4056	4789	5749	6720	7683	9559
	50	37	175	100	-	-	-	-	-	639	803	1014	1277	1612	2034	2568	3235	3819	4585	5359	6127	7623
	50*	37	175	100	-	-	-	-	-	691	869	1097	1382	1745	2201	2779	3501	4133	4961	5799	6631	8250
	60	45	225	125	-	-	-	-	-	-	675	852	1073	1355	1709	2158	2719	3210	3853	4504	5149	6407
	60*	45	225	125	-	-	-	-	-	-	705	890	1121	1415	1785	2254	2839	3352	4024	4704	5378	6691
	75	55	250	150	-	-	-	-	-	-	-	735	926	1168	1474	1861	2344	2768	3323	3884	4441	5525
	100	75	350	200	-	-	-	-	-	-	-	-	-	-	878	1108	1399	1762	2081	2498	2920	3338
125	93	450	250	-	-	-	-	-	-	-	-	-	-	-	893	1127	1420	1676	2012	2352	2689	3346
150	111	500	275	-	-	-	-	-	-	-	-	-	-	-	-	-	1162	1371	1646	1924	2200	2737

Lengths only meet the US National Electrical Code ampacity requirements for individual conductors rated 60° C in free air or water, NOT in magnetic enclosures, conduit or direct buried. Refer to NEC Table 310.15(B)(17) for more information.

* = motors are 8" diameter

SECTION 7: HITACHI® 6" AND LARGER SUBMERSIBLE MOTORS

7.6 MOTOR FUSE SIZING AND CABLE SELECTION

CABLE SELECTION : COPPER CABLE SIZE - FROM MAIN BREAKER PANEL TO MOTOR (IN FEET)

75° C

VOLTS /HZ	MOTOR			AWG														MCM				
	HP	KW	FUSE		14	12	10	8	6	4	3	2	1	0	00	000	0000	250	300	350	400	500
			STD	DUAL ELEMENT																		
THREE PHASE																						
230 V 60 Hz	5	4	45	25	149	237	378	598	931	1484	1865	2356	2967	3746	4726	5966	7516	8873	-	-	-	-
	8	6	60	35	-	155	247	391	609	970	1220	1540	1940	2449	3090	3901	4914	5802	6965	8142	9308	-
	10	8	80	45	-	-	195	308	479	764	961	1213	1529	1930	2434	3073	3872	4571	5488	6415	7334	9125
	15	11	125	70	-	-	-	221	344	548	689	871	1097	1384	1746	2205	2778	3279	3937	4602	5261	6546
	20	15	150	90	-	-	-	-	264	420	528	667	841	1061	1339	1690	2130	2514	3018	3528	4034	5019
	25	19	200	100	-	-	-	-	208	332	417	527	664	838	1057	1334	1681	1985	2383	2785	3184	3962
	30	22	225	125	-	-	-	-	-	268	337	426	537	677	855	1079	1359	1605	1926	2252	2575	3203
	40*	30	300	175	-	-	-	-	-	-	-	328	413	522	659	831	1047	1236	1484	1735	1984	2468
460 V 60 Hz	5	4	20	10	595	947	1511	2393	3723	5935	7461	9422	-	-	-	-	-	-	-	-	-	-
	8	6	30	15	389	619	988	1564	2434	3880	4878	6161	7761	9797	-	-	-	-	-	-	-	-
	10	8	40	20	307	488	778	1233	1918	3057	3844	4854	6115	7719	9738	-	-	-	-	-	-	-
	15	11	60	30	220	350	558	884	1376	2193	2757	3482	4387	5537	6986	8819	-	-	-	-	-	-
	20	15	80	45	-	-	428	678	1055	1682	2114	2670	3363	4245	5356	6761	8518	-	-	-	-	-
	25	19	100	50	-	-	338	535	833	1328	1669	2108	2655	3351	4228	5338	6725	7939	9531	-	-	-
	30	22	110	60	-	-	-	433	673	1073	1349	1704	2147	2710	3419	4316	5437	6419	7706	9008	-	-
	40	30	150	80	-	-	-	-	519	827	1040	1313	1654	2088	2634	3325	4189	4946	5937	6940	7935	9873
	40*	30	150	80	-	-	-	-	502	801	1007	1271	1601	2022	2550	3220	4056	4789	5749	6720	7683	9559
	50	37	175	100	-	-	-	-	-	639	803	1014	1277	1612	2034	2568	3235	3819	4585	5359	6127	7623
	50*	37	175	100	-	-	-	-	433	691	869	1097	1382	1745	2201	2779	3501	4133	4961	5799	6631	8250
	60	45	225	125	-	-	-	-	-	537	675	852	1073	1355	1709	2158	2719	3210	3853	4504	5149	6407
	60*	45	225	125	-	-	-	-	-	561	705	890	1121	1415	1785	2254	2839	3352	4024	4704	5378	6691
	75	55	250	150	-	-	-	-	-	-	582	735	926	1168	1474	1861	2344	2768	3323	3884	4441	5525
	100	75	350	200	-	-	-	-	-	-	-	-	-	696	878	1108	1399	1762	2081	2498	2920	3338
125	93	450	250	-	-	-	-	-	-	-	-	-	-	708	893	1127	1420	1676	2012	2352	2689	3346
150	111	500	275	-	-	-	-	-	-	-	-	-	-	-	922	1162	1371	1646	1924	2200	2737	

Lengths only meet the US National Electrical Code ampacity requirements for individual conductors rated 75° C in free air or water, NOT in magnetic enclosures, conduit or direct buried. Refer to NEC Table 310.15(B)(17) for more information.

*= motors are 8" diameter

SECTION 7: HITACHI® 6" AND LARGER SUBMERSIBLE MOTORS

7.6 MOTOR FUSE SIZING AND CABLE SELECTION

CABLE SELECTION: COPPER CABLE SIZE - FROM MAIN BREAKER PANEL TO MOTOR (IN FEET)

60° C

VOLTS /HZ	MOTOR			AWG														MCM					
	HP	KW	FUSE		14	12	10	8	6	4	3	2	1	0	00	000	0000	250	300	350	400	500	
			STD	DUAL ELEMENT																			
THREE PHASE																							
230 V 60 Hz	5	4	45	25	-	-	378	598	931	1484	1865	2356	2967	3746	4726	5966	7516	8873	-	-	-	-	
	8	6	60	35	-	-	-	391	609	970	1220	1540	1940	2449	3090	3901	4914	5802	6965	8142	9308	-	
	10	8	80	45	-	-	-	-	479	764	961	1213	1529	1930	2434	3073	3872	4571	5488	6415	7334	9125	
	15	11	125	70	-	-	-	-	-	548	689	871	1097	1384	1746	2205	2778	3279	3937	4602	5261	6546	
	20	15	150	90	-	-	-	-	-	-	528	667	841	1061	1339	1690	2130	2514	3018	3528	4034	5019	
	25	19	200	100	-	-	-	-	-	-	-	527	664	838	1057	1334	1681	1985	2383	2785	3184	3962	
	30	22	225	125	-	-	-	-	-	-	-	-	-	677	855	1079	1359	1605	1926	2252	2575	3203	
	40*	30	300	175	-	-	-	-	-	-	-	-	-	-	-	831	1047	1236	1484	1735	1984	2468	
460 V 60 Hz	5	4	20	10	595	947	1511	2393	3723	5935	7461	9422	-	-	-	-	-	-	-	-	-	-	
	8	6	30	15	-	619	988	1564	2434	3880	4878	6161	7761	9797	-	-	-	-	-	-	-	-	
	10	8	40	20	-	-	778	1233	1918	3057	3844	4854	6115	7719	9738	-	-	-	-	-	-	-	
	15	11	60	30	-	-	558	884	1376	2193	2757	3482	4387	5537	6986	8819	-	-	-	-	-	-	
	20	15	80	45	-	-	-	678	1055	1682	2114	2670	3363	4245	5356	6761	8518	-	-	-	-	-	
	25	19	100	50	-	-	-	-	833	1328	1669	2108	2655	3351	4228	5338	6725	7939	9531	-	-	-	
	30	22	110	60	-	-	-	-	-	1073	1349	1704	2147	2710	3419	4316	5437	6419	7706	9008	-	-	
	40	30	150	80	-	-	-	-	-	-	1040	1313	1654	2088	2634	3325	4189	4946	5937	6940	7935	9873	
	40*	30	150	80	-	-	-	-	-	-	1007	1271	1601	2022	2550	3220	4056	4789	5749	6720	7683	9559	
	50	37	175	100	-	-	-	-	-	-	-	-	1277	1612	2034	2568	3235	3819	4585	5359	6127	7623	
	50*	37	175	100	-	-	-	-	-	-	-	1097	1382	1745	2201	2779	3501	4133	4961	5799	6631	8250	
	60	45	225	125	-	-	-	-	-	-	-	-	-	1355	1709	2158	2719	3210	3853	4504	5149	6407	
	60*	45	225	125	-	-	-	-	-	-	-	-	-	-	1415	1785	2254	2839	3352	4024	4704	5378	6691
	75	55	250	150	-	-	-	-	-	-	-	-	-	-	1474	1861	2344	2768	3323	3884	4441	5525	
	100	75	350	200	-	-	-	-	-	-	-	-	-	-	-	-	1762	2081	2498	2920	3338	4153	
	125	93	450	250	-	-	-	-	-	-	-	-	-	-	-	-	-	-	2012	2352	2689	3346	
150	111	500	275	-	-	-	-	-	-	-	-	-	-	-	-	-	-	-	-	2200	2737		

Lengths meet the US National Electrical Code ampacity requirements for either individual conductors or jacketed rated 60° C cable and can be in conduit or direct buried. Flat molded and web/ribbon cable are considered jacketed cable. Refer to NEC Table 310.15(B)(16) for more information.

* = motors are 8" diameter

SECTION 7: HITACHI® 6" AND LARGER SUBMERSIBLE MOTORS

7.6 MOTOR FUSE SIZING AND CABLE SELECTION

CABLE SELECTION: COPPER CABLE SIZE - FROM MAIN BREAKER PANEL TO MOTOR (IN FEET)

75° C

VOLTS /HZ	MOTOR				AWG													MCM					
	HP	KW	FUSE		14	12	10	8	6	4	3	2	1	0	00	000	0000	250	300	350	400	500	
			STD	DUAL ELEMENT																			
THREE PHASE																							
230 V 60 Hz	5	4	45	25	-	237	378	598	931	1484	1865	2356	2967	3746	4726	5966	7516	8873	-	-	-	-	
	8	6	60	35	-	-	247	391	609	970	1220	1540	1940	2449	3090	3901	4914	5802	6965	8142	9308	-	
	10	8	80	45	-	-	-	308	479	764	961	1213	1529	1930	2434	3073	3872	4571	5488	6415	7334	9125	
	15	11	125	70	-	-	-	-	344	548	689	871	1097	1384	1746	2205	2778	3279	3937	4602	5261	6546	
	20	15	150	90	-	-	-	-	-	420	528	667	841	1061	1339	1690	2130	2514	3018	3528	4034	5019	
	25	19	200	100	-	-	-	-	-	-	417	527	664	838	1057	1334	1681	1985	2383	2785	3184	3962	
	30	22	225	125	-	-	-	-	-	-	-	-	537	677	855	1079	1359	1605	1926	2252	2575	3203	
	40*	30	300	175	-	-	-	-	-	-	-	-	-	-	659	831	1047	1236	1484	1735	1984	2468	
460 V 60 Hz	5	4	20	10	595	947	1511	2393	3723	5935	7461	9422	-	-	-	-	-	-	-	-	-	-	
	8	6	30	15	389	619	988	1564	2434	3880	4878	6161	7761	9797	-	-	-	-	-	-	-	-	
	10	8	40	20	-	488	778	1233	1918	3057	3844	4854	6115	7719	9738	-	-	-	-	-	-	-	
	15	11	60	30	-	-	558	884	1376	2193	2757	3482	4387	5537	6986	8819	-	-	-	-	-	-	
	20	15	80	45	-	-	-	678	1055	1682	2114	2670	3363	4245	5356	6761	8518	-	-	-	-	-	
	25	19	100	50	-	-	-	535	833	1328	1669	2108	2655	3351	4228	5338	6725	7939	9531	-	-	-	
	30	22	110	60	-	-	-	-	673	1073	1349	1704	2147	2710	3419	4316	5437	6419	7706	9008	-	-	
	40	30	150	80	-	-	-	-	-	827	1040	1313	1654	2088	2634	3325	4189	4946	5937	6940	7935	9873	
	40*	30	150	80	-	-	-	-	-	801	1007	1271	1601	2022	2550	3220	4056	4789	5749	6720	7683	9559	
	50	37	175	100	-	-	-	-	-	803	1014	1277	1612	2034	2568	3235	3819	4585	5359	6127	7623		
	50*	37	175	100	-	-	-	-	-	869	1097	1382	1745	2201	2779	3501	4133	4961	5799	6631	8250		
	60	45	225	125	-	-	-	-	-	-	-	-	1073	1355	1709	2158	2719	3210	3853	4504	5149	6407	
	60*	45	225	125	-	-	-	-	-	-	-	-	890	1121	1415	1785	2254	2839	3352	4024	4704	5378	6691
	75	55	250	150	-	-	-	-	-	-	-	-	-	-	1168	1474	1861	2344	2768	3323	3884	4441	5525
	100	75	350	200	-	-	-	-	-	-	-	-	-	-	-	1399	1762	2081	2498	2920	3338	4153	
125	93	450	250	-	-	-	-	-	-	-	-	-	-	-	-	1420	1676	2012	2352	2689	3346		
150	111	500	275	-	-	-	-	-	-	-	-	-	-	-	-	-	-	1646	1924	2200	2737		

Lengths meet the US National Electrical Code ampacity requirements for either individual conductors or jacketed rated 75° C cable and can be in conduit or direct buried. Flat molded and web/ribbon cable are considered jacketed cable. Refer to NEC Table 310.15(B)(16) for more information.

* = motors are 8" diameter

SECTION 7: HITACHI® 6" AND LARGER SUBMERSIBLE MOTORS

7.7 OVERLOAD PROTECTION

Submersible motors must have Class 10 overload protection that will disconnect the power within 10 seconds in the case of a locked rotor. To accomplish this, fixed-heater overloads are used. The chart is based upon total line amps. Divide the motor amps by 1.732 when using a 6-lead motor with a Y-Delta Starter. **NOTE:** General Electric® overload heaters are only usable with General Electric® overload relays. Do not adjust relays to exceed nameplate amps.

7.8 MOTOR COOLING

Hitachi 6" motors are designed for minimum water flow of 0.5 ft. /sec. past the motor. Maximum water temperature is 95° F (35° C).

6" motors: Minimum cooling water flow:

I.D of casing Flow (GPM) required

6	9
7	25
8	40
10	85
12	140
14	200
16	280

If the flow is less than specified, a flow-inducer sleeve can be installed. This will act like a smaller casing size, and force flow around the motor to aid cooling. Always use a flow-inducer sleeve when the pump is in open water.

7.9 HEAD LOSS IN CASING

USE THE CHART BELOW TO ACCOUNT FOR THE HEAD LOSS AROUND THE PUMP.

HEAD LOSS IN FEET FOR FLOW PAST MOTOR

6" MOTORS		CASING INSIDE DIAMETER		
		6"	7"	8"
GPM	100	1.7		
	150	3.7		
	200	6.3	0.5	
	250	9.6	0.8	
	300	13.6	1.2	0.2
	400	23.7	2.0	0.4
	500		3.1	0.7
	600		4.4	1.0

7.10 STARTING FREQUENCY

To extend the life of the pump motor and control, limit the number of starts to 100 per 24 hours. If higher starting frequencies are necessary, consult your factory. To prevent overheating, run motor for a minimum of two minutes. For starting frequency, refer to section 5.10.

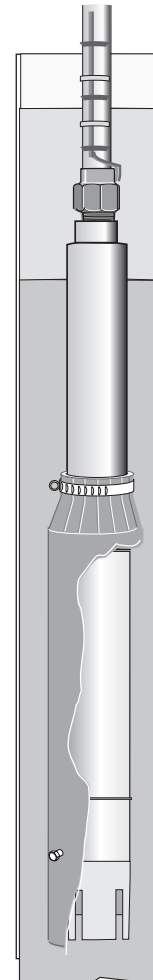

SECTION 7: HITACHI® 6" AND LARGER SUBMERSIBLE MOTORS

7.11 TROUBLESHOOTING

PROBLEM	POSSIBLE CAUSES	SOLUTION
Motor does not start but does not blow fuses or relay.	No power supply. Defective connections.	Replace fuses, breakers or check for loose or corroded connections and motor lead terminals. Correct connections.
Fuses or relay blow when motor starts.	Incorrect voltage. Incorrect fuses or relay. Defective capacitors. Wrong connections.	Apply correct voltage. Voltage must be plus or minus 10% of rated (Nameplate). Replace with proper fuses and relay. Replace with proper capacitors. Correct wrong connections or short circuit. Locked rotor conditions. Correct pump or well conditions. Insulation resistance down. Check the line and correct.
Motor runs for a while and then blown fuses or relay.	Low voltage or high voltage. Defective capacitors. Different control box for the motor. Defective starting voltage relay. Pump is sand clogged. Overheated protector.	Apply rated voltage. Replace with proper capacitors. Replace with proper control box. Replace with proper relay. Pull pump and clean well. Shield the control box from heat source.

SECTION 8: PENTEK INTELLIDRIVE™ VARIABLE FREQUENCY DRIVES

8.1 GENERAL SAFETY

⚠ WARNING CAN SHOCK, BURN, OR KILL. Risk of high-voltage electrical shock from EMI/RFI filter inside drive. Can shock, burn or kill if the front cover of the Pentek Intellidrive is open or removed while power is connected to the Drive or the Drive is running. The front cover of the Drive must be closed during operation.

- ◆ Make all wiring connections, then close and fasten the cover before turning on power to drive.
- ◆ NEVER open the box when power is connected to Drive.
- ◆ Before doing any service or maintenance inside Drive or when connecting or disconnecting any wires inside Drive:
 1. DISCONNECT power.
 2. WAIT 5 minutes for retained voltage to discharge.
 3. Open box.
- ◆ Before starting any wiring or inspection procedures, check for residual voltage with a voltage tester.
- ◆ NEVER connect power wiring to Drive before mounting the box.
- ◆ NEVER handle or service Drive with wet or damp hands. Always make sure hands are dry before working on Drive.
- ◆ NEVER reach into or change the cooling fan while power is applied to Drive.
- ◆ NEVER touch the printed circuit board when power is applied to Drive.
- ◆ **⚠ WARNING RISK OF FIRE.** Can cause severe injury, property damage or death if installed with incorrect or inadequate circuit breaker protection. To ensure protection in the event of an internal fault in the Pentek Intellidrive, install the Drive on an independent branch circuit protected by a circuit breaker (see Table 8-2 for circuit-breaker sizing), with no other appliances on the circuit.

⚠ CAUTION RISK OF BURNS. The Drive can become hot during normal operation. Allow it to cool for 5 minutes after shut-down and before handling it to avoid burns.

To avoid damage to or problems with Drive:

- ◆ Connect output cables to **three-wire, one-phase**, and **three-phase** submersible motors as follows:
 - Red to R, Yellow to Y, Black to B.Any other order will reverse the motor rotation and may damage the motor.
- ◆ Connect output cables to **two-wire, one-phase** submersible motors as follows:
 - **Connect to Y and B only.**
 - Connect Ground to green screw.
- ◆ Above ground three-phase motors may have different lead colors. Generally connect output leads as follows:
 - R to L1, Y to L2, B to L3.
 - Verify rotation after startup.
- ◆ Do not modify equipment.
- ◆ Do not use power factor correction capacitors as they will damage both motor and Pentek Intellidrive.
- ◆ Do not remove any parts unless instructed to do so in Owner's Manual.
- ◆ Do not use a magnetic contactor on Drive for frequent starting/stopping.
- ◆ Do not install or operate Drive if it is damaged or parts are missing.
- ◆ Before starting Drive that has been in storage, always inspect it and test operation.
- ◆ Do not carry out a megger (insulation resistance) test on the control circuit of the Drive.
- ◆ Do not allow loose foreign objects which can conduct electricity (such as screws and metal fragments) inside Drive box at any time. Do not allow flammable substances (such as oil) inside Drive box at any time.
- ◆ Ground Drive according to the requirements of the National Electrical Code Section 250, IEC 536 Class 1, or the Canadian Electrical Code (as applicable), and any other codes and ordinances that apply.
- ◆ All installation, service work, and inspections must be done by qualified electrician.

SECTION 8: PENTEK INTELLIDRIVE™ VARIABLE FREQUENCY DRIVES

8.2 DESCRIPTION

SPECIFICATIONS

- ◆ Input Voltage: one-phase 230VAC Nominal (190-265VAC).
- ◆ Input Frequency: 50/60Hz.
- ◆ Ambient Temperature Range : Less Than 120° F (50° C).
- ◆ Output Connections: three-phase, three-wire/one-phase or one-phase/two-wire.
- ◆ Max Motor Cable Length: 1,000 feet.
- ◆ Enclosure: NEMA 3R.

TABLE 8-1: SPECIFICATIONS

MODEL	MOTOR TYPE*	HP RANGE	MAXIMUM OUTPUT AMPS	INPUT VOLTAGE	ENCLOSURE TYPE
PID10	2-WIRE 1-PHASE	0.5-1 HP	9.5A	190V - 265V	NEMA 3R outdoor
	3-WIRE 1-PHASE	0.5-1 HP	7.5A		
	3-PHASE	0.5-1 HP	5A		
PID20	2-WIRE 1-PHASE	0.5-1.5 HP	11A		
	3-WIRE 1-PHASE	0.5-2 HP	13.5A		
	3-PHASE	0.5-2 HP	8.5A		
PID30	2-WIRE 1-PHASE	0.5-1.5 HP	11A		
	3-WIRE 1-PHASE	0.5-2 HP	13.5A		
	3-PHASE	0.5-3 HP	11.5A		
PID50	2-WIRE 1-PHASE	0.5-1.5 HP	11A		
	3-WIRE 1-PHASE	0.5-2 HP	13.5A		
	3-PHASE	0.5-5 HP	18A		

*Select drives by S.F. amps of pump motor.

The Pentair Pentek Intellidrive® Constant Pressure Pump Controller is specifically designed to operate 4” submersible pumps and three-phase above ground pumps in water well and residential booster applications. Each Intellidrive is rated for maximum output amp rating. Any use of it outside of intended design parameters will void warranty. If Intellidrive is used with above ground motors not rated for a Variable Frequency Drive, maximize motor life by limiting lead length to 25 ft.

Refer to pump’s Owner’s Manual and the National Electrical Code for proper wire size.

Each carton contains:

- ◆ Pentek Intellidrive Variable Frequency Drive
- ◆ Pressure Transducer
- ◆ 10’ Pressure Transducer Cable
- ◆ Quick Start Guide
- ◆ Installation and Operation Manual
- ◆ Pentek Intellidrive Model Number Structure.

PIDXX

Product Family
PID - PENTEK INTELLIDRIVE

HP Range

- 10 = up to 1.0 HP
- 20 = up to 2.0 HP
- 30 = up to 3.0 HP
- 50 = up to 5.0 HP

The PID10 will operate a one-phase two-wire, one-phase three-wire, and three-phase motor up to 1HP.

The PID20 will operate a one-phase two-wire up to 1.5HP and a one-phase three-wire or three-phase motor up to 2HP.

The PID30 will operate a one-phase two-wire up to 1.5HP, one-phase three-wire up to 2HP or three-phase motor up to 3HP.

The PID50 will operate a one-phase two-wire up to 1.5HP, one-phase three-wire up to 2HP, or three-phase motor up to 5HP.

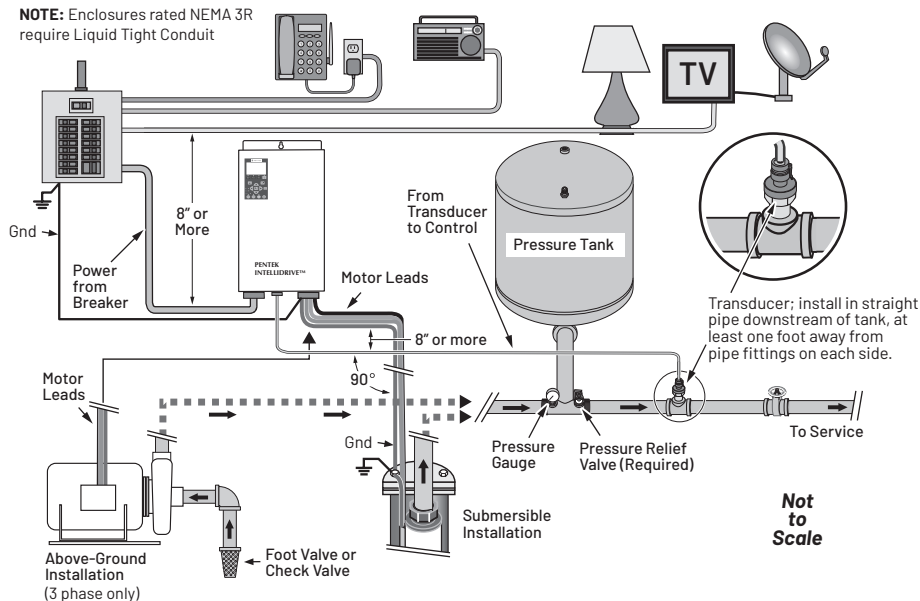

Figure 8-1: A typical residential installation layout

SECTION 8: PENTEK INTELLIDRIVE™ VARIABLE FREQUENCY DRIVES

TRANSDUCER

The Intellidrive uses a 4-20mA, 0-100 PSI pressure transducer to control motor speed. Settings may be changed to use a max 300 PSI transducer.

The transducer (Fig Refer to pump’s Owner’s Manual and the National Electrical Code for proper wire size).

The transducer senses pressure in the pipe and converts it to an electrical signal. The Intellidrive senses and processes the signal in the PID (Proportional, Integration, Derivative) Control.

When operating in AUTOSTART mode, the Intellidrive increases and decreases the speed of the pump motor as needed to maintain constant pressure in the piping system.

KEYPAD

The keypad programs the Pentair Pentek Intellidrive® Constant Pressure Pump Controller, monitors the status of the pump, and displays faults if they occur. Each button has a unique function (Figure 8-2).

The LCD display shows a text display of the status of the Intellidrive’s operation. Other LEDs light up to indicate when certain buttons are pressed or certain events occur.

FAN

The Intellidrive uses a thermostatically controlled internal fan which operates automatically when necessary to cool the Intellidrive components.

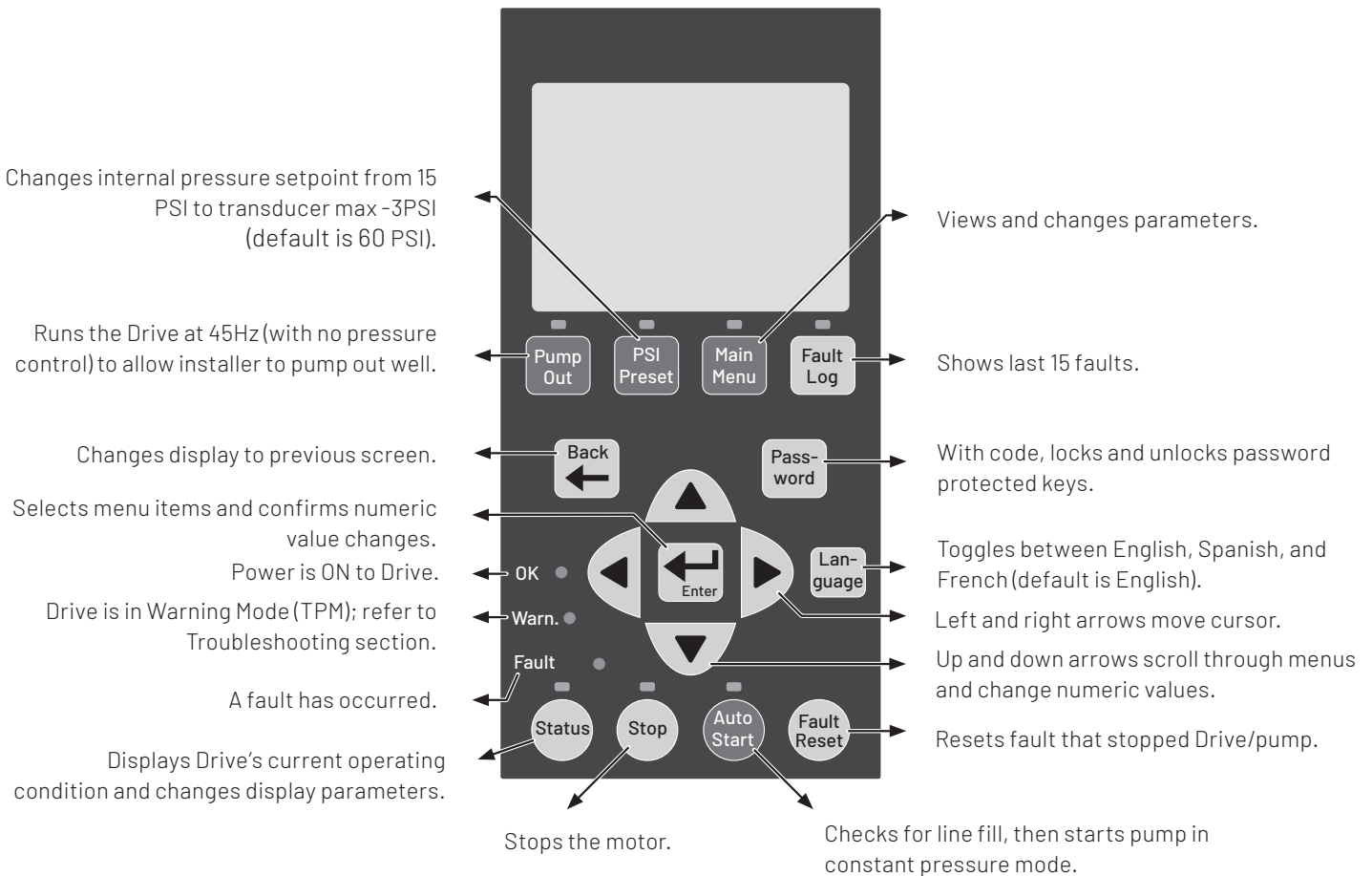

Figure 8-2: Pentek Intellidrive Keypad Functions

SECTION 8: PENTEK INTELLIDRIVE™ VARIABLE FREQUENCY DRIVES

8.3 INSTALLATION

TABLE 8-2: CIRCUIT BREAKER AND WIRE SIZES

MOTOR	VOLTS	MOTOR HP	INPUT WIRE SIZE	CIRCUIT BREAKER*	GENERATOR (KVA)**
2-Wire	230	1/2	14	15	2.2
	230	3/4	12	15	3.1
	230	1	12	20	4.4
	230	1-1/2	10	25	5.3
3-Wire	230	1/2	14	15	2.3
	230	3/4	12	15	3.0
	230	1	12	15	3.5
	230	1-1/2	10	25	5.3
	230	2	10	25	5.8
3-Phase	230	1/2	14	15	2.1
	230	3/4	14	15	2.8
	230	1	12	15	3.4
	230	1-1/2	12	20	4.4
	230	2	10	25	5.5
	230	3	10	30	7.3
	230	5	6	50	12.6

*With properly-sized circuit breakers, the Intellidrive is protected from short circuit on the input and the output. There is no risk of fire or electrical shock due to a short circuit. The Intellidrive has NEC Class 10 overload protection.

** Minimum 240V generator size.

INSTALLATION MOUNTING

To mount the Pentair Pentek Intellidrive® Constant Pressure Pump Controller:

1. First, remove the cover by backing out screw at bottom of front cover.
2. Push on backplate with thumbs while pulling the cover toward you with index fingers, creating a gap (Figure 8-3 and 8-4).
3. Pull the bottom of the cover towards you. Lift up on cover and remove (Figure 8-5).
4. With the cover removed, permanently mount the Intellidrive using the top slotted hole, plus either the three bottom holes (for flat surface mounting) or the center bottom hole (for attaching to a post or stud). See Figure 8-6.
5. Ensure the Intellidrive’s ventilation holes are not blocked and there is enough space around it to allow free air flow (minimum 3” clearance on top, bottom, and sides). See Figure 8-6. Once the Intellidrive is mounted, electrical wiring can be connected.

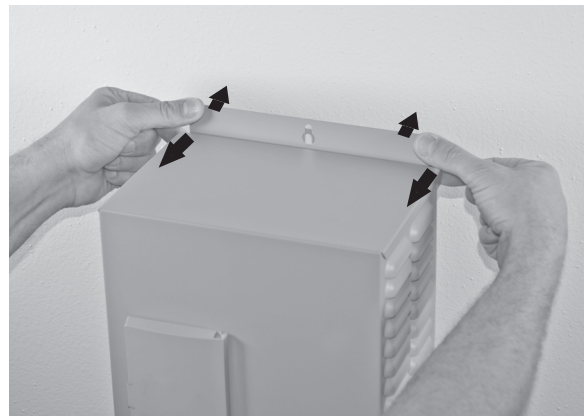

Figure 8-3: Separate Cover And Back

SECTION 8: PENTEK INTELLIDRIVE™ VARIABLE FREQUENCY DRIVES



Figure 8-4: Cover And Backplate Gap

6. To reattach the Intellidrive cover, hook the top of it on backplate (be sure to leave a gap). Lower bottom of cover into place. Push cover evenly against backplate, eliminating the gap. See Figure 8-7.
7. Replace screw at bottom of front cover.



Figure 8-5: Pull Cover

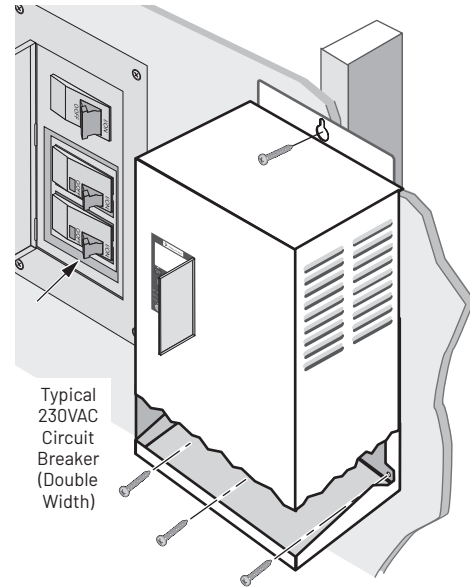

Figure 8-6: Separate Cover And Back

WIRING

To allow for ease of wiring, the enclosure wiring area is free of electronics other than the terminals. Conduit holes and knockouts are located so that the wire can be fed straight through to the connectors, with minimal bending. The terminals accept 6-14 AWG wire.

Installations that require larger wire gauge than 6 AWG will require an external junction box. Run 6 AWG wire from the Intellidrive into the junction box, then make external connections with wire nuts to appropriately sized wire.

NOTE: For convenience in wiring, the input and motor terminals unplug from the box. Pull them down to remove them for ease of access (Figure 8-8).

Verify that the terminal connectors are completely seated when you replace them. It is best practice to connect all output wires (larger wire gauge) first, then all input wires.

SECTION 8: PENTEK INTELLIDRIVE™ VARIABLE FREQUENCY DRIVES

PUMP CONNECTIONS

If the Pentair Pentek Intellidrive® Constant Pressure Pump Controller is used with above ground motors (three-phase only) not rated for Variable Frequency Intellidrive use, maximize motor life by limiting lead length to 25 ft. Refer to the pump’s owner’s manual, the National Electrical Code, and local codes for proper wire size.

The output of the Intellidrive is single phase (two-wire or three-wire) or three-phase, depending on motor selection during startup. The output power terminals (motor wire connections) are located on the lower right side of the Intellidrive and are labeled R (Red), Y (Yellow), and B (Black).

To select the wire size, multiply the wire length by 0.95 and then refer to the pump owner’s manual, the Nation Electric Code, and local codes for proper wire size.

NOTE: Regardless of owner’s manual, wire LENGTH may not exceed 1000 ft. (305 M).

NOTE: two-wire one-phase connect to Y+B, not R+B.

FAN

The Intellidrive uses a thermostatically controlled internal fan which operates automatically when necessary to cool the Intellidrive components.

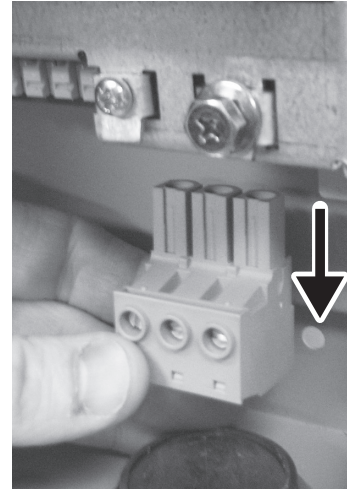
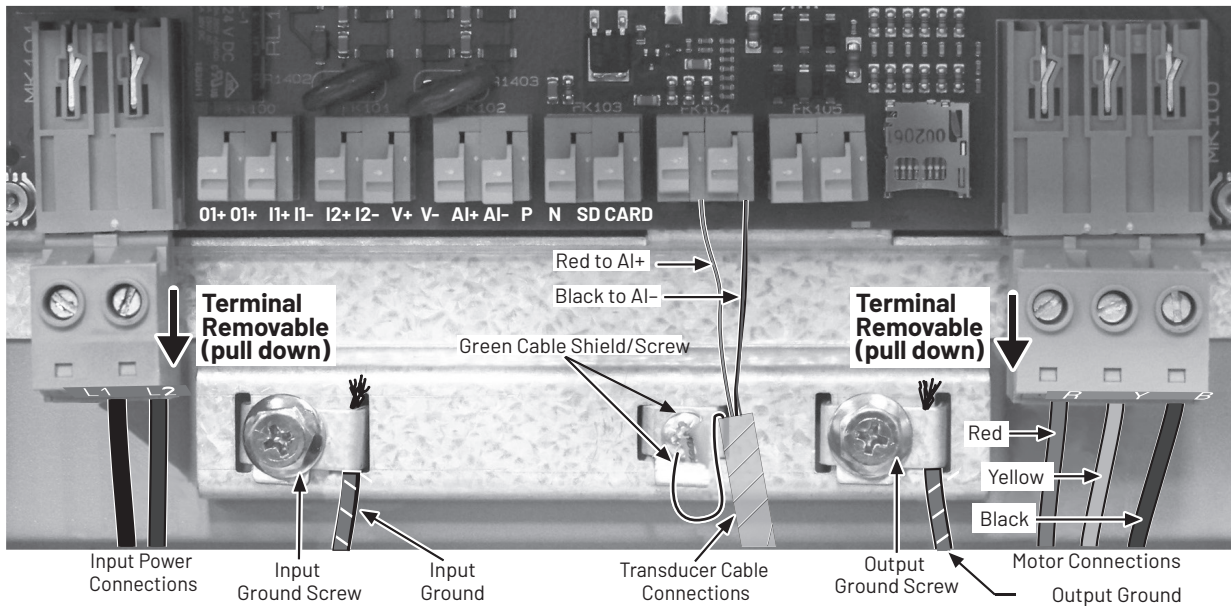

Figure 8-7: Keyboard



Submersible Motor: 3-Ph./ 3-W. 1-Ph., follow colors as above.
Submersible Motor: 1-Ph./ 2-W., connect to Y and B, any order.
Above-Ground Motors: L1 to R, L2 to Y, L3 to B; verify rotation.

Figure 8-8: Basic Wiring Connections

SECTION 8: PENTEK INTELLIDRIVE™ VARIABLE FREQUENCY DRIVES

PRESSURE TANK RECOMMENDATIONS

Minimum tank size is two gallons. Use a pre-charged pressure tank with Intellidrive, as shown in Table 8-3. The tank size must equal at least 20 percent of the pump's rated flow in gallons per minute (GPM), but cannot be less than two gallons capacity.

For example, a pump rated at 7 GPM would require a tank of two gallons capacity or larger. A pump rated at 50 GPM would require a 10 gallon tank or larger. Tanks larger than 10 gallons can be used, but may require adjustment of Wake Delay parameter.

TABLE 8-3: CONTROL PRESSURE SET POINT AND TANK PRE-CHARGE PRESSURE VALUES (PSI)

PRESSURE POINT SETTING (PSI)	PRECHARGE PRESSURE (PSI)	PRESSURE POINT SETTING (PSI)	PRECHARGE PRESSURE (PSI)
25	18	65	46
30	21	70	49
35	25	75	53
40	28	80	56
45	32	85	60
50	35	90	63
55	39	95	67
60(Default)	42	-	-

Set pressure tank's pre-charge to 70 percent of the system operating pressure. When using an external set point as well as an internal set point, pre-charge tank to 70 percent of the lower setpoint of the two. Some applications may require a different percentage when determining the setpoint.

TRANSDUCER CONNECTIONS

A 0-100 PSI 4-20 mA transducer is provided with Intellidrive. Install the transducer downstream of tank, as shown in Figure 8-1. Install transducer in a tee in a straight section of pipe with at least 1 foot of straight pipe on each side of the tee (i.e., all fittings must be at least 1 foot away from transducer).

Feed transducer cable through the open 1/2" conduit hole on bottom of the Intellidrive enclosure.

Connect the red wire of the transducer cable to AI+, connect black wire to AI-, and connect the cable shield to the metal cable shield screw.

To connect the transducer wires:

1. Strip wire 1/2 inch.
2. Push spring terminal up with finger or slotted screw Intellidriver.
3. Insert wires from bottom.
4. Release spring terminal.

INPUT POWER CONNECTIONS

- ◆ The input power terminals are located on the lower left side and are marked L1 and L2.
- ◆ There is a ground screw for the input ground wire to the right of the connector (torque to 10 inch lbs).
- ◆ Feed wire through the 3/4" conduit hole on the bottom left side and into appropriate terminals.
- ◆ If wire is large enough to require a larger conduit hole, remove the 1-1/4" knockout and use appropriate conduit connections. To determine the correct wire sizes for installation, see Table 8-4.
- ◆ The Pentair Pentek Intellidrive® Constant Pressure Pump Controller only accepts 230V single phase input power. If incoming power does not match this, have a qualified electrician alter supply voltage to 230V/1Ph before connecting it to the Intellidrive.

SECTION 8: PENTEK INTELLIDRIVE™ VARIABLE FREQUENCY DRIVES

8.4 INITIAL STARTUP AND PROGRAMMING PROCEDURES

Ensure that the cover is installed before operating the Pentair Pentek Intellidrive® Constant Pressure Pump Controller.

Most installations will only require the initial startup settings. However, the installer may need to set additional parameters.

Information about accessing all parameters, explanations of their functions, and procedures for changing parameter values, will be found later in this section.

TABLE 8-4: PENTEK MOTOR SERVICE FACTOR AMPS

MOTOR TYPE	PART NUMBER	RATING @ 230V	
		HP	SERVICE FACTOR AMPS
2-Wire	P42B0005A2-01	1/2	4.7
	P42B0007A2-01	3/4	6.2
	P42B0010A2-01	1	8.1
	P42B0015A2-01	1-1/2	10.4
	P42B0005A2-02	1/2	5.1
	P42B0007A2-02	3/4	6.1
	P42B0010A2-02	1	8.0
	P42B0015A2-02	1 1/2	10.6
	P42B0005A2	1/2	4.7
	P42B0007A2	3/4	6.4
	P42B0010A2	1	9.1
	P42B0015A2	1-1/2	11.0
CS/CR 3-Wire	P43B0005A2-01	1/2	4.8
	P43B0007A2-01	3/4	6.0
	P43B0010A2-01	1	7.3
	P43B0015A2-01	1-1/2	10.9
	P43B0005A2-02	1/2	4.5
	P43B0007A2-02	3/4	5.7
	P43B0010A2-02	1	6.8
	P43B0015A2-02	1 1/2	10.7
	P43B0005A2	1/2	4.9
	P43B0007A2	3/4	6.3
	P43B0010A2	1	7.2
	P43B0015A2	1-1/2	11.1
3-Phase	P43B0020A2	2	12.2
	P43B0005A3	1/2	2.9
	P43B0007A3	3/4	3.9
	P43B0010A3	1	4.7
	P43B0015A3	1-1/2	6.1
	P43B0020A3	2	7.6
	P43B0030A3	3	10.1
P43B0050A3	5	17.5	

1. Program the Intellidrive: Apply power to the device. Setup Guide will appear in the display. Follow keypress sequence shown in Figure 8-9.

NOTE: If Setup Guide does not appear, refer to Intellidrive Reset Procedure (Figure 8-18).

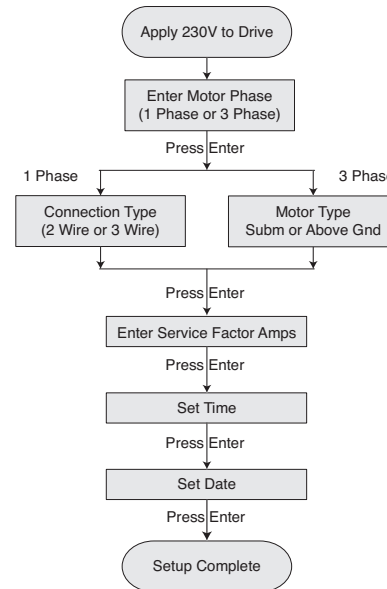

Figure 8-9: Intellidrive Setup Guide

2. Select 80 Hz Operation, if necessary (See 60 Hz to 80 Hz Operation for more information):
 - ◆ Press MAIN MENU button.
 - ◆ Follow the keypress sequence shown in Figure 8-10.

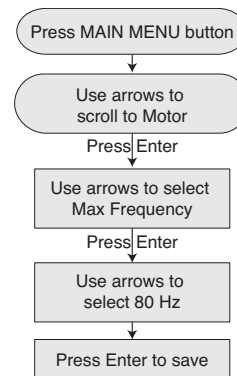

Figure 8-10: Select 80 Hz (Three-phase submersible operation only)

3. Pump out well, if necessary. Direct discharge to appropriate location not connected to system and press Pump Out. The pump will run at 45 Hz. Adjust frequency as appropriate:
 - ◆ Press ENTER.
 - ◆ Change frequency value. Above ground pumps should run at 60 Hz for this step (until pump is primed). Then adjust frequency as necessary.
 - ◆ Press ENTER again.

SECTION 8: PENTEK INTELLIDRIVE™ VARIABLE FREQUENCY DRIVES

8.4 INITIAL STARTUP AND PROGRAMMING PROCEDURES

- ◆ Run the Pentair Pentek Intellidrive® Constant Pressure Pump Controller in this mode until the well discharge runs clear, then press the STOP button.
 - ◆ **⚠ WARNING RISK OF EXPLOSION.** In Pump Out mode, pump runs at a constant speed, which can cause very high pressure if flow is restricted.
 - ◆ Press ENTER again.
4. Verify installation. Make sure that the system has properly-sized, pressure-relief valve and pressure tank.
- ◆ Make sure pressure tank's precharge is correct (Table 8-6).
 - ◆ Make sure pump discharge is connected to system.
5. System Start:
- ◆ Open valves at the ends of lines so that air will escape during pressurization.
 - ◆ Press Auto Start; close valves at the ends of lines after all air has escaped.
 - ◆ The system goes into Constant Pressure Operation as soon as the transducer registers the Dry Run Sensitivity parameter. Default is 10 PSI.
 - ◆ If system pressure does not reach that PSI value within 3 minutes, the Intellidrive will stop. Press Auto Start again to restart line fill. If longer priming or line fill time is required, adjust Fill Time parameter. See Table 8-5.

SERVICE FACTOR AMPS

To maximize pump performance, be sure to enter the correct Service Factor Amps (SF Amps) in the Intellidrive.

- ◆ Entering SF Amps higher than the motor rating lets the Intellidrive supply more amps to the motor than the motor is designed for and may allow the motor to overheat. See Table 8-4.
- ◆ Entering SF Amps lower than the motor rating limits the output amps to less than the motor is designed for and will reduce the performance of the pump.
- ◆ For any one-phase three-wire motor, the correct Service Factor Amp rating for the Intellidrive is Cap Start/Cap Run amps (see Table 8-4). This may not match the motor nameplate, which (for a Single Phase, three-wire motor) will generally be Cap Start/ Induction Run Amps.
- ◆ For any three-phase or one-phase, two-wire motor, use the motor nameplate Service Factor Amp rating.

- ◆ Pentek submersible motors may differ from motors of the same horsepower from other manufacturers.
- ◆ For one-phase, three-wire motors from all other submersible motor manufacturers, enter the motor manufacturer's CS/CR service factor amps for your motor.
- ◆ For three-phase or two-wire one-phase motors, use the motor nameplate amp value. Also see Retro Fit Applications (Table 8-7).

CHANGING A PARAMETER VALUE

This procedure works for ANY parameter.

- A. Press MAIN MENU button.

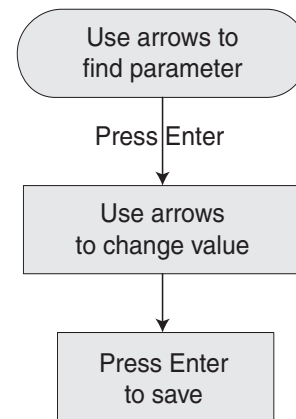

Figure 8-11: Changing parameter value

- B. Follow the keypress sequence shown in Figure 8-12.

A shorthand way to remember this is:

- ◆ Press ENTER to highlight a value.
- ◆ Use arrows to change value.
- ◆ Press ENTER again to save it.
- ◆ If new value is not saved, any screen change will result in the loss of the new value.
- ◆ Table 8-5 lists all available commands and parameters.

SECTION 8: PENTEK INTELLIDRIVE™ VARIABLE FREQUENCY DRIVES

8.5 ADVANCED PROGRAMMING

60 HZ TO 80 HZ OPERATION

When installing the Pentair Pentek Intellidrive® Constant Pressure Pump Controller with a motor and liquid end of the same HP rating, operate it at 60 Hz (the default value). The Intellidrive can be operated at frequencies of up to 80 Hz when the installation uses a three-phase motor 2 times the size of the pump.

For example, a 1 HP pump with a 2 HP, three-phase motor. This combination will equal the performance of a conventional 2 HP pump.

- ◆ Press Main Menu and follow the keypress sequence shown in Figure 8-11. Be sure to press ENTER to save the new Max Frequency selected. The Intellidrive will now use the new value selected.

NOTE: The Intellidrive will not allow the output amps to go above the Service Factor Amps selected on the keypad. Because of this, some 80 Hz operations may be limited. This protects the motor and may be a common occurrence in a 80Hz operation.

KEYPAD LOCK - PASSWORD

The password locks or unlocks the blue buttons on keypad (Figure 8-2). All Intellidrive units are shipped from factory with the default password 7777. It can be changed to any other 1 to 4 digit number. To reset password to a unique password for unit, unlock keypad and follow the keypress sequence (Figure 8-11) to make the change.

If installer does not press the password button, then the keypad will automatically lock 60 minutes after the Intellidrive is powered up. The time out period is adjustable (see Table 8-5).

To unlock keypad press Password, use directional arrows to select numeric code and press ENTER.

PUMP OUT OPERATION

1. Verify Keypad is unlocked.
2. Press Pump Out Key.
3. Intellidrive will ask "Is The Valve Open?" and the default answer "No" will be displayed. Press ENTER to highlight "NO", use arrows to change display to "Yes", press ENTER.
4. The Intellidrive will start pump in a constant speed mode (default 45Hz). The pump will run until STOP or Auto Start are pressed.
5. If speed change is necessary, press enter to highlight value, use arrows to change value, then press enter to save.
NOTE: Above ground pumps should run at 60Hz for this step (until pump is primed). Then adjust frequency as necessary.

SETTING THE PRESSURE

1. Default pressure setting is 60 PSI. If this value is changed, adjust tank pressure accordingly (Table 8-3).
2. The Over Pressure parameter may need to be adjusted if the default pressure setting is increased. Do not set the Over Pressure parameter above the operating pressure of the pressure relief valve in the water system.
3. There are three ways to change the pressure setpoint:
 - ◆ While running the pump: Follow keypress sequence shown in Figure 8-12 to make desired change. This parameter allows either Internal or External Setpoint to be changed, depending on which one is referenced at the time the change is made.
 - ◆ Via the PSI Preset (Figure 8-13).
 - ◆ Via the Main Menu (Main Menu/Settings/Setpoint/Internal Setpoint).
4. The I/O terminals are located in the center of the wiring compartment (Figure 8-9).
 - ◆ The Digital Input connections (I1 and I2) are used to control the Intellidrive based on the state of an external device, such as a flow switch, moisture sensor, alternator, or other device. Programming is needed to activate any of these functions (see Table 8-5).
 - ◆ The Output Relay (O1) is used to control an external device based on two states of Intellidrive; either Running the pump or Faulted. Programming is needed to activate any of these functions (see Table 8-5).

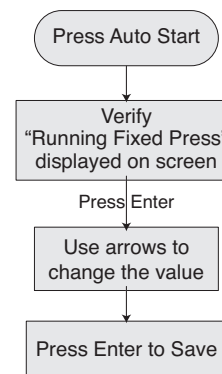

Figure 8-12: Pump Running: Change PSI Setpoint

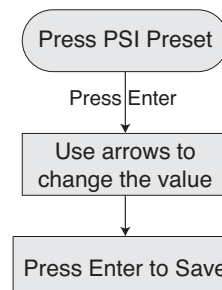

Figure 8-13: PSI Preset: Change PSI Setpoint

SECTION 8: PENTEK INTELLIDRIVE™ VARIABLE FREQUENCY DRIVES

The following (Table 8-5) lists all available commands and parameters for the Pentair Pentek Intellidrive® Constant Pressure Pump Controller .

TABLE 8- 5: MAIN MENU AND PARAMETERS

MENU SETTINGS	PARAMETER	UNIT OF MEASURE	VALUE			DESCRIPTION
			DEFAULT	MIN.	MAX.	
Time/Date	Hour Format	Hours	12Hr	12Hr	24Hr	Selects 12 or 24 hour time scale.
	Time	HH:MM	1:00 AM	1	24	Sets current time. Used for time stamp in fault log.
	Date	MM/DD/YYYY	1/1/12	-	-	Sets current date. Used for date stamp in fault log.
PID Control	Proportional Gain	-	1500	0	10000	Sets the PID controller gain. Used in conjunction with all PID Control parameters to control how fast or slow the Intellidrive reacts to pressure changes.
	Integration Time	Milliseconds	1500 ms	20 ms	65000 ms	Sets the PID controller integration time. Used in conjunction with all PID Control parameters to control how fast or slow Intellidrive reacts to pressure changes.
	Derivation Time	Milliseconds	60 ms	0 ms	10000 ms	Sets PID controller derivation time. Used in conjunction with all PID Control parameters to control how fast or slow Intellidrive reacts to pressure changes.
	Derivative Limit	-	120	0	2000	Sets derivative filter time constant for PID controller.
Sleep	Boost Differential	PSI	3 PSI	3 PSI	10 PSI	First part of Boost Process. Pressure boost that happens before it goes to Wake Delay.
	Boost Delay	MM:SS	1 Min	30 Sec	5 Min	The time Intellidrive takes to start Boost Process after system has stabilized.
	Wake Up Differential	PSI	5 PSI	5 PSI	15 PSI	Pressure amount below setpoint that wakes up Intellidrive.
	Wake Delay	MM:SS	15 Sec	3 Sec	2 Min	Second part of the Boost Process. The time it takes to ramp down pressure during the Boost Process.
Password	Password Time Out	HH:MM	1 Hr	1 Min	6 Hr	Amount of time it takes to lock keypad (after last button is pressed).
	Password	-	7777	0000	9999	Password used to unlock keypad.
Setpoints	Internal Setpoints	PSI	60 PSI	15 PSI	Max Sensor Value minus 3 PSI	Main pressure setpoint used. Sets main system operational pressure. This parameter is accessed here, through PSI Preset button, or by pressing Enter button while in Constant Pressure operation.
	External Setpoints	PSI	40 PSI	15 PSI	Max Sensor Value minus 3 PSI	Second pressure setpoint. When another pressure setting is desired other than Internal Setpoint. Additional programming needed in I/O section. Requires an external switch or timer to be wired to digital input terminals. It is only active when there is voltage present at the digital input terminals.
SUB MENU	PARAMETER	UNIT OF MEASURE	DEFAULT	MIN	MAX	DESCRIPTION
Motor	Motor Phase	-	1	1	3	Selects phase of motor to be operated. An additional sub menu will appear, based on phase selection, to select proper motor type.
	Connection Type	-	3 wire	3 wire	2 wire	Wire type for 1 phase motor operation only. Can only access by first setting Motor Phase parameter to 1 Phase.
	Motor Type	-	Subm	Subm	Above Gnd	Motor type for 3 phase motor operation only. Can only access by first setting Motor Phase parameter to 3 Phase.
	Service Factor Amps	A	00.0 A	00.0 A	Per Intellidrive and motor	Service factor amps (max. load) of motor the Intellidrive is operating. Sets maximum allowed amps at output of Intellidrive. See Table 8-8 for values.
	Min Frequency	Hz	30 Hz	30 Hz	1 below Max Hz	Minimum frequency (speed) motor will run.
	Max Frequency	Hz	60 Hz	1 above Min Hz	80 Hz	Maximum frequency (speed) motor will run. Up to 80Hz is only available on submersible three-phase motors (when motor is 2x the HP of pump).
Sensor	Max Sensor Value	PSI	100 PSI	100 PSI	300 PSI	Maximum pressure value of transducer sensor used with Intellidrive. Only change if different transducer is used with Intellidrive, other than 100 PSI max scale.

SECTION 8: PENTEK INTELLIDRIVE™ VARIABLE FREQUENCY DRIVES

TABLE 8-5: MAIN MENU AND PARAMETERS (CONTINUED)

MENU SETTINGS	PARAMETER	UNIT OF MEASURE	VALUE			DESCRIPTION
			DEFAULT	MIN.	MAX.	
Time/Date	Hour Format	Hours	12Hr	12Hr	24Hr	Selects 12 or 24 hour time scale.
	Time	HH:mm	1:00 AM	1	24	Sets current time. Used for time stamp in fault log.
	Date	MM/DD/YYYY	1/1/12	-	-	Sets current date. Used for date stamp in fault log.
PID Control	Proportional Gain	-	1500	0	10000	Sets the PID controller gain. Used in conjunction with all PID Control parameters to control how fast or slow the Drive reacts to pressure changes.
	Integration Time	Milliseconds	500 ms	20 ms	65000 ms	Sets the PID controller integration time. Used in conjunction with all PID Control parameters to control how fast or slow Drive reacts to pressure changes.
	Derivation Time	Milliseconds	60 ms	0 ms	10000 ms	Sets PID controller derivation time. Used in conjunction with all PID Control parameters to control how fast or slow Drive reacts to pressure changes.
	Derivative Limit	-	120	0	2000	Sets derivative filter time constant for PID controller.
Sleep	Boost Differential	PSI	3 PSI	3 PSI	10 PSI	First part of Boost Process. Pressure boost that happens before it goes to Wake Delay.
	Boost Delay	MM:SS	1 Min	30 Sec	5 Min	The time Drive takes to start Boost Process after system has stabilized.
	Wake Up Differential	PSI	5 PSI	5 PSI	15 PSI	Pressure amount below setpoint that wakes up Drive.
	Wake Delay	MM:SS	15 Sec	3 Sec	2 Min	Second part of the Boost Process. The time it takes to ramp down pressure during the Boost Process.
Password	Password Time Out	HH:mm	1 Hr	1 Min	6 Hr	Amount of time it takes to lock keypad (after last button is pressed).
	Password	-	7777	0000	9999	Password used to unlock keypad.

SECTION 8: PENTEK INTELLIDRIVE™ VARIABLE FREQUENCY DRIVES

TABLE 8-5: MAIN MENU AND PARAMETERS (CONTINUED)

MENU SETTINGS	PARAMETER	UNIT OF MEASURE	VALUE			DESCRIPTION
			DEFAULT	MIN	MAX	
Setpoints	Internal Setpoint	PSI	60 PSI	15 PSI	Max Sensor Value minus 3 PSI.	Main pressure setpoint used. Sets main system operational pressure. This parameter is accessed here, through PSI Preset button, or by pressing Enter button while in Constant Pressure operation.
	External Setpoint	PSI	40 PSI	15 PSI	Max Sensor Value minus 3 PSI.	Second pressure setpoint. When another pressure setting is desired other than Internal Setpoint. Additional programming needed in I/O section. Requires an external switch or timer wired to I1 or I2 terminals. It is only active when there is voltage present I1 or I2 terminals.
SUB MENU	PARAMETER	UNIT OF MEASURE	DEFAULT	MIN	MAX	DESCRIPTION
Motor	Motor Phase	-	1	1	3	Selects phase of motor to be operated. An additional sub menu will appear, based on phase selection, to select proper motor type.
	Connection Type	-	3 wire	2 wire	3 wire	Wire type for 1 phase motor operation only. Can only access by first setting Motor Phase parameter to 1 Phase.
	Motor Type	-	Subm	Subm	Above Gnd	Motor type for 3 phase motor operation only. Can only access by first setting Motor Phase parameter to 3 Phase.
	Service Factor Amps	A	00.0 A	00.0 A	Per drive and motor	Service factor amps (max. load) of motor the Drive is operating. Sets maximum allowed amps at output of Drive. See Table 8-7 for values.
	Min Frequency	Hz	30 Hz	30 Hz	1 below Max Hz	Minimum frequency (speed) motor will run.
	Max Frequency	Hz	60 Hz	1 above Min Hz	80 Hz	Maximum frequency (speed) motor will run. Up to 80Hz is only available when Motor Phase is set to 3 and motor type is Sub. Motor HP must be 2x size of pump.
Sensor	Max Sensor Value	PSI	100 PSI	100 PSI	300 PSI	Maximum pressure value of transducer sensor used with Drive. Only change if different transducer is used with Drive, other than 100 PSI max scale.

SECTION 8: PENTEK INTELLIDRIVE™ VARIABLE FREQUENCY DRIVES

TABLE 8-5: MAIN MENU AND PARAMETERS (CONTINUED)

MENU SETTINGS	PARAMETER	UNIT OF MEASURE	VALUE			DESCRIPTION
			DEFAULT	MIN.	MAX.	
Ex Runtime	Excessive Runtime Detection	-	Disabled	Disabled	Enabled	Enables or disables Excessive Runtime Detection.
	Excessive Runtime Hours	Hours	24	1	100	Number of hours Intellidrive can run before it faults on Excessive Runtime.
Dry Run	Auto Restart Delay	Minutes	10 Min	3 Min	60 Min	Time Pentair Pentek Intellidrive® Constant Pressure Pump Controller waits to restart pump when Dry Run is detected.
	Number of Resets	-	3	0	5	Number of tries Intellidrive attempts to restart pump when Dry Run condition is detected.
	Detection Time	M:SS	15 Sec	5 Sec	10 Min	Time the Intellidrive takes to recognize Dry Run condition.
	Sensitivity	PSI	10	0	300	Pressure value that Dry Run condition is detected at. Dry Run fault will occur if this pressure cannot be met within Detection Time window. Lower pressure = less sensitivity.
	Fill Time	M:SS	1 M	15 S	10 M	Time allowed to fill (prime) pipes during Auto Line Fill process. Relates to Dry Run Sensitivity value. (Time starts after 55 Hz is reached).
I/O	Digital Input 1	-	Unused	-	-	Selects operation of Intellidrive when terminal I1 or I2 is used. Select between Unused, Run Enabled, Ext Fault, and Setpoint. The Intellidrive will respond to selected command when voltage is present at I1 or I2 terminal.
	Digital Input 2	-	Unused	-	-	
	Relay Output	-	Unused	-	-	Selects the operation of Intellidrive when terminal O1 is used. Select between Unused, Run, and Fault. The Intellidrive closes the Relay when Run or Fault is selected.
Over Press	Over Pressure	PSI	80 PSI	15 PSI	97 PSI	Sets Over Pressure Warning value. Change if higher than 80 PSI system pressure is needed.
No Ground	No Ground Detection	-	Enabled	Disabled	Enabled	Selects whether Ground Detection parameter is Enabled or Disabled. If Disabled is selected, it will revert back to Enabled after 72 hours. Warning LED will flash entire time it is Disabled.
Reset	Factory Reset	-	No	No	Yes	Resets all parameters to factory defaults. Displays Setup Guide after it is complete. Software version displayed here. Does not clear fault log.
SW Update	Software Update	-	Disabled	Disabled	Enabled	Used to update software, if necessary.

SECTION 8: PENTEK INTELLIDRIVE™ VARIABLE FREQUENCY DRIVES

8.6 I/O CONNECTIONS

CABLE INSTALLATION

Three 1/2" conduit knockouts are provided on the bottom of the Pentair Pentek Intellidrive® Constant Pressure Pump Controller enclosure for the I/O wires.

Break out the closest 1/2" knockout and route the wires through. Use a cord grip to prevent the wire from rubbing and causing a short.

NOTE: Never run low voltage I/O wire through the same conduit hole as the 230V input wires or motor wires.

To connect the external wires to the terminals:

1. Strip wire 1/2 inch.
2. Push spring terminal up with finger or slotted screwdriver.
3. Insert wires from bottom.
4. Release spring terminal.

CONNECTION EXAMPLES

Figures 8-15 through 8-17 show various connection schemes for typical applications. Table 8-6 describes each I/O terminal, including purpose and rating.

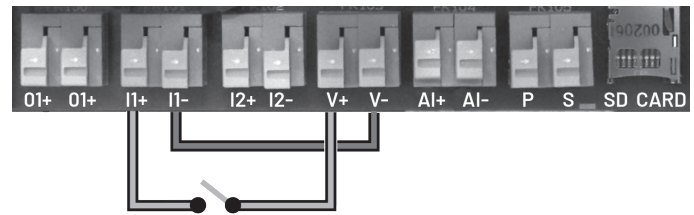

Figure 8-14: Input with Internal 24 Volt Supply

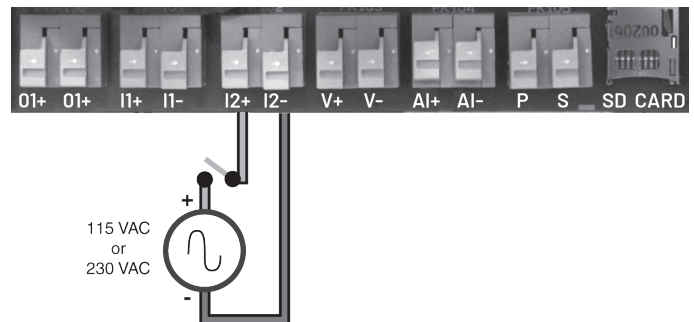

Figure 8-15: External Input with External Supply

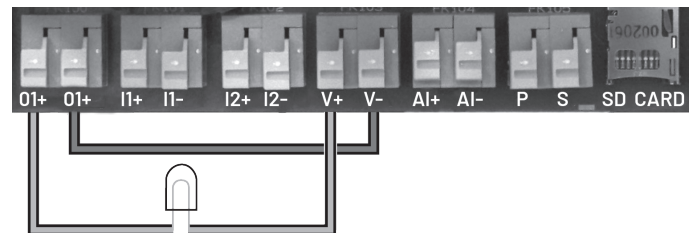

Figure 8-16: Output Relay with Internal 24 Volt Supply

SECTION 8: PENTEK INTELLIDRIVE™ VARIABLE FREQUENCY DRIVES

TABLE 8-6: I/O FUNCTION, CONNECTIONS, RATINGS

LABEL	FUNCTION	CONNECTION	RATING
AI+	Positive connection for transducer.	Red transducer wire.	24 Volt (supplied)
AI-	Negative connection for transducer.	Black transducer wire.	24 Volt (supplied)
V+	Positive side of 24 volt power supply. Used to power external devices.	Positive side of 24V external device, i.e., flow switch, moisture sensor, alternator, etc. Need to complete the circuit with V-. See Figures 8-15 and 8-17.	40mA maximum output
V-	Negative side of 24 volt power supply. Used to power external devices.	Typically to I1-, I2-, or O1+. Used with a flow switch, moisture sensor, alternator, etc. Need to complete the circuit with V+. See Figures 8-15 and 8-17.	40mA maximum output
I1+	Positive connection of Digital Input 1. Connect when using an external device to control Intellidrive.	From an external device i.e., flow switch, moisture sensor, alternator, etc. Requires complete circuit connection with I1-. See Figures 8-15 and 8-16.	Accepts 24VDC and up to 230VAC
I1-	Negative connection of Digital Input 1. Connect when using an external device to control Intellidrive.	Can be from V- or from the negative side of an external power supply. Requires complete circuit connection with I1+. See Figures 8-15 and 8-16.	Accepts 24VDC and up to 230VAC
I2+	Positive connection of Digital Input 2. Connect when using an external device to control Intellidrive.	From an external device, i.e., flow switch, moisture sensor, alternator, etc. Requires complete circuit connection with I2-. See Figures 8-15 and 8-16.	Accepts 24VDC and up to 230VAC
I2-	Negative connection of Digital Input 2. Connect when using an external device to control Intellidrive.	Can be from V- or from the negative side of an external power supply. Requires complete circuit connection with I2+. See Figures 8-15 and 8-16.	Accepts 24VDC and up to 230VAC
O1+	Output relay (dry contacts) connection. Programmed to close when pump is Running or Faulted.	Positive wires of an external device. See Figures 8-17 and 8-18.	Accepts up to 5 Amps at 24VDC and 8 Amps at up to 230VAC *Only non-inductive loads
O1+	Output relay (dry contacts) connection. Programmed to close when pump is Running or Faulted.	Positive wires of an external device. See Figures 8-17 and 18.	Per RS-485 Standard
P	Positive connection of an RS-485 communication device (see Figure 8-18).	Positive wire from RS-485 device.	Per RS-485 Standard
N	Negative connection of an RS-485 communication device (see Figure 8-18).	Negative wire from RS-485 device.	

SECTION 8: PENTEK INTELLIDRIVE™ VARIABLE FREQUENCY DRIVES

RS-485 COMMUNICATIONS

RS-485 is a US-based telecommunications standard for binary serial communications between devices. It is the protocol, or set of specifications, that needs to be followed to allow devices that implement the standard to speak to each other.

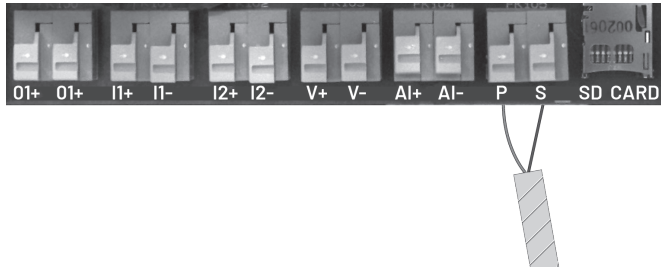

Figure 8-17: Example RS-485 Connection

A fully compliant RS-485 port is included in the Pentair Pentek Intellidrive® Constant Pressure Pump Controller system to permit serial connections among more than two devices on an RS-485 compliant network. Figure 8-17 shows two-wire connection to the Intellidrive.

8.7 WIRING SIZING, REPAIR PARTS, SPECIFICATIONS

LIGHTNING/SURGE PROTECTION

Lightning arrestors or other surge suppressing devices can be used with this product. MOV (Metal Oxide Varistor), SOV (Silicon Oxide Varistor).

RETROFIT APPLICATIONS

When retrofitting an installation, most of the preceding text can be applied. As a convenience, the recommended Service Factor Amps for non-Pentek motors is provided in Table 8-7.

Always verify Service Factor Amp values from current manufacturer literature.

INTELLIDRIVE RESET PROCEDURE

Follow this keypress sequence to test the Intellidrive (Figure 8-18).

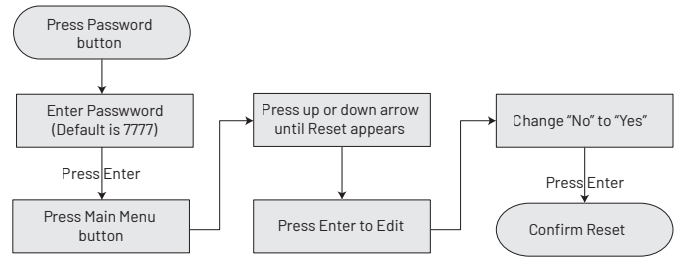

Figure 8-18: Keypress Sequence For Testing

NOTE: In a domestic environment, this product may cause radio interference which may require supplementary mitigation measures.

TABLE 8-7 - SERVICE FACTOR AMPS @ 230V¹

MOTOR TYPE	HP	SERVICE FACTOR RATING, IN AMPS	
		CENTRIPRO ¹	FRANKLIN ²
2-Wire	1/2	4.7	N/A
	3/4	6.4	
	1	9.1	
	1-1/2	11.0	
CS/CR 3-Wire	1/2	4.9	4.3
	3/4	6.3	5.7
	1	7.2	7.1
	1-1/2	11.1	11.5
3-Phase	2	12.2	13.2
	1/2	2.9	2.9
	3/4	3.9	3.8
	1	4.7	4.7
	1-1/2	6.1	5.9
	2	7.6	8.1
	3	10.1	10.9
5	17.5	17.8	

¹ CentriPro SFA data was taken from the March 2012 BMAID manual on 4/2012.

² Franklin Electric SFA data was taken from the 7/2011 Franklin Electric AIM manual on 4/2012.

NOTE: The Pentek Intellidrive will not operate Franklin Electric two-wire motors.

SECTION 8: PENTEK INTELLIDRIVE™ VARIABLE FREQUENCY DRIVES

SOFTWARE UPDATES

To determine whether you need to update, compare the software version number in your Pentair Pentek Intellidrive® Constant Pressure Pump Controller against the software you plan to install.

⚠ WARNING READ ALL SAFETY INSTRUCTIONS IN THIS MANUAL BEFORE UPDATING THE INTELLIDRIVE.

1. If using the information at <https://www.pentair.com/en/brands/pentek/pentair-pentek-Intellidrive-software-update.html>, please note that some internet browsers need to be refreshed to show the most current software files.
2. Press Ctrl+F5 to refresh the webpage to verify that it is displaying the latest data.



Figure 8-19: Software Version

3. To find the software version number currently loaded on your Intellidrive, press the password key on the keypad.
4. Enter your password, and press Enter.
5. Press the Main Menu key followed by the up arrow key until SW Update is displayed, press Enter.
6. The bottom row of information indicates your existing software version. If the version number you plan to install is higher than what is currently on the Intellidrive, an update is in order.
7. Follow the directions below to update your software.

DOWNLOADING SOFTWARE TO THE SD CARD

SD cards are typically used in digital cameras and can be purchased in the electronics/camera section of most retail outlets. Minimal storage space is needed for these files.

Cards as small as 1GB have more than enough space. Use only standard size SD cards; micro and mini SD cards will not work.

1. Before downloading new files from www.sta-rite.com/PIDupdate, verify that the SD card is empty.
2. Using the links above, download the AOC and MOC files to the SD card.

UPDATING SOFTWARE ON THE INTELLIDRIVE

1. Before moving forward with the software update, make note of the set up parameters used in the Intellidrive.

2. Remove power from the Intellidrive. Confirm by seeing text and light disappear from keypad. Power is normally removed using a switch in the breaker box or switch in the fuse box.
3. Remove the plastic guard from the SD card slot (Figure 8-20).
4. Insert SD card into the slot in the Intellidrive.
5. Reapply power to the Intellidrive.
6. Using the password, unlock the Intellidrive.
7. Press the Main Menu key, press the up arrow key until SW Update is displayed and press Enter.
8. Set the parameter "Software Update" to "Enabled" by pressing enter to "highlight" the word Disabled.
 - ◆ Press the up arrow key to change the parameter to Enabled.
 - ◆ Press enter to "save" the change (the word "Enabled" will no longer be highlighted when saved).
9. Remove power from the Intellidrive. Confirm by seeing the text and lights disappear from keypad.
10. Reapply power to the Intellidrive.
11. Wait while software updates. The screen will remain blank for about 90 seconds while this happens. When text reappears software upload is complete.
12. When the startup guide appears, enter data as prompted. See Initial Startup section of this manual as needed.
13. In the main menu go to the parameter group "SW Update" and press Enter.
14. Verify parameter "Software Update" now displays "Disabled".
15. Verify software version shows the version you intended to install.
16. Change other setup parameters using the previously recorded notes.
17. Remove power from the Intellidrive. Confirm by seeing the text and light disappear from keypad.
18. Remove SD card.
19. Replace plastic guard. This helps protect the terminals inside the slot from corrosion, etc.
20. The software update is complete.

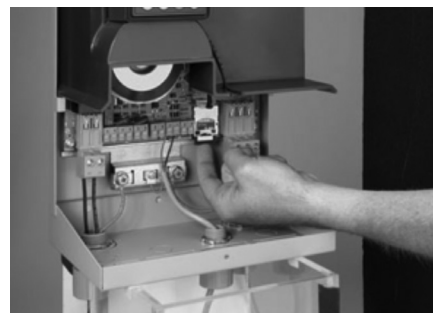

Figure 8-20: Software Version

SECTION 8: PENTEK INTELLIDRIVE™ VARIABLE FREQUENCY DRIVES

8.8 TROUBLESHOOTING

FAULT	POSSIBLE CAUSES	SOLUTION	
Over Current	Shorted output.	Check for any shorts in motor cables.	
	Damaged wire insulation.	Check motor wire insulation with a megger.	
	Missing Phase in three-phase motor.	Ohm cable and motor to confirm balanced Ohms.	
	Entered wrong Service Factor Amps.	Review motor parameters in main menu.	
Over Voltage	Internal Pentair Pentek Intellidrive® Constant Pressure Pump Controller short.	With power to Intellidrive off, measure outputs with ohmmeter to detect short.	
	Power cycling on and off.	Check for a generator or switching on input line.	
	High line voltage.	Measure incoming line voltage to Intellidrive; should be between 190V and 265V.	
Low line voltage.			
Under Voltage	Temporary loss of power.	Check for local power outage.	
	Excessive load current.	Check motor is correctly sized for the application.	
	Loss of a motor phase.	Check correct voltage is present on all motor leads.	
	Power was removed from Intellidrive.	Check correct voltage is present on all input lines.	
	Cannot Start Motor	Exceeding Service Factor Amps.	Check Service Factor Amps entered are correct. Check pump and motor are correct.
		No Service Factor Amps value entered.	Check Service Factor Amps entered and are correct.
There is an open (connection) in motor wires.		Check resistance of all motor wires is correct.	
Locked rotor.		Pull pump check for debris in pump.	
Dry Run	Operation at open discharge.	May need to reduce Dry Run Sensitivity pressure or apply back pressure on transducer.	
	Intellidrive cannot read transducer signal.	Check linearity of transducer, as it may be damaged.	
	Possible leak.	Check for pipe break or large leak.	
	Dry running pump.	Check water level in well.	
Ground Fault	Ground wire shorted to motor phase.	Check the ground wire for short to motor phase wire or check insulation integrity with a megger.	
	Long motor cable length.	Motor cable length more than 1000 ft is not recommended.	
System Not Grounded	Ungrounded Intellidrive.	Ground Detect parameter can be disabled, but will reactivate after 72 hours.	
	Unbalanced or three phase incoming voltage.	Line to line voltage must be twice line to ground voltage.	
FAULT	POSSIBLE CAUSES	SOLUTION	
Open Transducer	Intermittent connection.	Check all transducer wires are securely connected or for damaged cable insulation.	
	Open Connection.	Check for proper wiring of all transducer wires and verify cable connector securely attached to transducer.	
	Intellidrive cannot read transducer signal.	Check electrical system for ground loops or no ground connection.	
	Transducer wires crossed.	Check red is in AI+ and black is in AI-.	
	Possible failed transducer.	Check linearity of transducer.	
Shorted Transducer	Short in transducer wires.	Check for shorted transducer wire or damaged insulation.	
	Possible failed transducer.	Check linearity of transducer.	

SECTION 8: PENTEK INTELLIDRIVE™ VARIABLE FREQUENCY DRIVES

FAULT	POSSIBLE CAUSES	SOLUTION
Over Temperature	Excessive heating in Pentair Pentek Intellidrive® Constant Pressure Pump Controller.	Check ambient temperature is not above 50°C (122°F).
		Check for inoperable or unobstructed fan.
		Check vents are not obstructed.
Excessive Runtime	Leak detected.	Check for leaks in pipe system.
	Application calls for long run times.	Extend Excessive Runtime Hours limitation.
		Disable Excessive Runtime Fault.
Internal Fault	Internal voltages are out of range.	Intellidrive will auto reset and attempt to clear fault. Fault Reset can be pressed to clear fault as well. Then try to operate pump. If fault continues Intellidrive may need replacement.
Hardware Fault	Internal hardware failure.	Fault Reset can be pressed to clear fault. Then try to operate pump. If fault continues Intellidrive may need replacement.
External Fault	The external device detected fault condition and closed the I1 or I2 input.	Check external device.
Low Amps	Motor not wired correctly to Intellidrive.	2-Wire motor should be connected to Y & B.
	Thermal protector open in 1-phase motor.	Wait 20 minutes then restart pump.
	Missing motor phase.	Check all motor connections at the Intellidrive.
WARNING	POSSIBLE CAUSES	SOLUTION
Warning LED flashing	Ungrounded Intellidrive, with ground detection parameter disabled (will operate for 72 hours and then fault).	Verify ground wire is connected on both incoming voltage side and motor side of Intellidrive.
		With the power disconnected, use an ohmmeter to verify which pipe the Intellidrive's transducer is connected to. Also verify that the input ground wire is at the same potential, e.g., has approximately the same ohm reading.
		Verify the input ground is connected all the way back to electrical panel.
Jam Warning	Debris in pump stopping motor from turning (locked rotor).	Intellidrive tries to free debris in pump by reversing or pulsing motor.
Over Pressure Warning	Pressure rising above Over Pressure setting.	Intellidrive stops and waits 1 minute, then checks that pressure is below the Overpressure Setting pressure. Below it restarts, if not checks again in another minute. Can increase over-pressure value.
Temp Derate	Plugged vents, fan not working, high ambient temp, direct sunlight, etc. Also high power draw.	Improve ventilation, verify fan is working, provide shade, etc. Verify proper system sizing.
Hardware Fault	Internal Intellidrive error.	Power cycle the Intellidrive. If Fault continues Intellidrive may need replacement.
Parameter Out of Range	Internal Intellidrive error.	Power cycle the Intellidrive. Reset Intellidrive to factory defaults. If Fault continues, Intellidrive may need replacement.
Temp Meas Error	Internal Intellidrive error.	Power cycle the Intellidrive.
DC Undervoltage	Low voltage on DC Bus caused by heavy loading, low incoming voltage, or unbalanced output current.	Check wiring for shorts, imbalance, and voltage. Verify proper grounding.

SECTION 9: PENTEK INTELLIDRIVE™ XL PRODUCT SELECTION GUIDE

9.1 HOW TO SELECT YOUR DRIVE

This selection guide will help you specify the correct drive and accessories required for your application.

STEP 1: SELECT THE DRIVE

CHOOSE INPUT PHASE, VOLTAGE, AND MOTOR AMPS	SELECT ENCLOSURE	CHOOSE DISCONNECT TYPE
1 Phase, 200-240V, 16.7-88A	IP20/Open Chassis - To be mounted inside another enclosure.	None (ND) - No disconnect included with the drive.
1 Phase, 380-480V, 14.5-65A	NEMA 1 - Indoor locations.	Standard (SD) - Integrated disconnect in the drive.
3 Phase, 200-240V, 4.6-170A	NEMA 12 - Indoor locations with protection against dirt/dust and dripping/splashing water.	Fused (FD) - Integrated and fused disconnect in the drive.
3 Phase, 380-480V, 2.1-730A	NEMA 3R - Outdoor and indoor locations with protection against dirt/dust and rain, sleet, and snow.	
3 Phase, 525-600V, 1.7-630A	NEMA 4X - Outdoor and indoor locations with protection against dirt/dust and rain, sleet, and snow and hose directed water.	

STEP 2: SELECT REQUIRED FILTER/REACTOR*

Variable frequency drives produce voltage spikes that are a function of voltage rise-time and length of motor cable. In extreme cases peak voltage may exceed three times the nominal operating voltage.

Reactors

A reactor is a resistance and inductance device that reduces voltage spikes. It does this by both increasing the voltage rise-time and improving the impedance match of the cable and motor.

Filters

A filter combines a reactor with a capacitor network. The capacitors absorb a portion of the voltage spikes. This further reduces the peak voltage seen at the motor.

When to Use a Reactor or Filter:

The chart below is a general guideline when choosing between using a filter or reactor.

MOTOR TYPE	LEAD LENGTH					
	UP TO 50'		50' TO 150'		150' TO 1000'	
	230V	460V	230V	460V	230V	460V
NEMA Above-Ground Std. Efficiency			R			
NEMA Above-Ground Premium Efficiency	-	-	-	R	F	F
Submersible		R	R	F		

R=Reactor F=Filter

The following list indicates a greater need for filters and reactors:

- ◆ Long motor leads are used.
- ◆ Standard efficiency or submersible motors are used.
- ◆ The cost of replacing the motor is prohibitive.
- ◆ Using a submersible motor with a voltage rating greater than 230V.
- ◆ The quality and/or age of the motor is unknown.
- ◆ Condition of wiring and/or power quality is unknown.

FILTERS

NEMA 3R, 230V, 460V OR 575V	RATED AMPS
MODEL	
V1K2A03	2
V1K3A03	3
V1K4A03	4
V1K6A03	6
V1K8A03	8
V1K12A03	12
V1K18A03	18
V1K25A03	25
V1K27A03	27
V1K35A03	35
V1K45A03	45
V1K55A03	55
V1K80A03	80
V1K110A03	110
V1K130A03	130
V1K160A03	160

REACTORS

OPEN DESIGN 230 OR 460V	RATED AMPS
MODEL	
KDRD1P	21
KDRD2P	27
KDRH1P	124

NEMA1 575 V	RATES AMPS
MODEL	
KDRD31PC2	17
KDRD32PC2	124

All of our products are backed by expert, dedicated technical support that is available to quickly and efficiently resolve any issues or answer questions about selecting a drive. For technical issues and immediate assistance, please call 866.973.6835. ¹Item not included in drive purchase.

SECTION 9: PENTEK INTELLIDRIVE™ XL PRODUCT SELECTION GUIDE

REACTORS

ENCLOSED DESIGN 230 OR 460V	RATED AMPS
MODEL	
KDRD1PC2	21
KDRD2PC2	27
KDRD3PC2	34
KDRD4PC2	40
KDRC1PC2	52
KDRF1PC3	65
KDRF2PC3	77
KDRF3PC4	96
KDRH1PC4	124

STEP 3: SELECT A TRANSDUCER[^]

100PSI	300PSI
U17-1561-R	Transducer, 0-100psi 4-20 MA
U17-2000	Transducer 300psi

STEP 4: SELECT A TRANSDUCER CABLE[^]

CATALOG NUMBER	DESCRIPTION
VFD-10TCB	Transducer Cable 10FT
VFD-20TCB	Transducer Cable 20FT 3R
VFD-50TCB	Transducer Cable 50FT 3R
VFD-100TCB	Transducer Cable 100FT 3R
VFD-200TCB	Transducer Cable 200FT 3R

9.2 NOMENCLATURE

Model Number

Model
PID

Horsepower
0010 = 1 HP
0075 = 7.5 HP
0100 = 10 HP
1000 = 100 HP

Enclosure
0 = IP20/Open chassis
1 = NEMA 1
2 = NEMA 12
3 = NEMA 3R
4 = NEMA 4X

Voltage
2 = 230V, 1 PH
3 = 230V, 3 PH
4 = 460V, 3 PH
5 = 575V, 3 PH
9 = 460V, 1 PH

Fused Disconnect
ND = No Disconnect
SD = Standard Disconnect
FD = Fused Disconnect

Backplate
Blank = None
BP = with Backplate

Revision Code
Blank = None
-01 = First revision

Note: Horsepower is only approximate. Verify VFD size using motor Service Factor Amps. Failure to verify may result in the VFD not turning the motor at full speed or failure to start the motor.

PID 0010 1 2 FD BP -01

APPROXIMATE DIMENSIONS

FRAME SIZE	A2	A3	A4	A5	B1	B2	B3	B4	C1	C2	C3	C4	D1	D2	E1
Depth (in)	9	9	7	8	10	10	10	10	12	13	13	13	15	15	19
Width (in)	4	5	8	10	10	10	7	9	12	15	12	15	13	17	24
Height (in)	11	11	17	17	19	26	16	20	27	30	21	26	36	44	79

SECTION 9: PENTEK INTELLIDRIVE™ XL PRODUCT SELECTION GUIDE

9.3 PRODUCT DETAILS

230V ONE-PHASE INPUT DRIVES (VARIOUS ENCLOSURES, NO DISCONNECT)

OUTPUT AMPS*	INPUT VOLTAGE	INPUT PHASE	NEMA RATING	PENTAIR PART NUMBER	PART DESCRIPTION	WEIGHT	FRAME**
16.7	200-240	1	1	PID005012ND	VFD NEMA 1 ND 16.7A 230V 1PH	51	B1
24.2	200-240	1	1	PID007512ND	VFD NEMA 1 ND 24.2A 230V 1PH	51	B1
30.8	200-240	1	1	PID010012ND	VFD NEMA 1 ND 30.8A 230V 1PH	60	B2
59.4	200-240	1	1	PID020012ND	VFD NEMA 1 ND 59.4A 230V 1PH	99	C1
88	200-240	1	1	PID030012ND	VFD NEMA 1 ND 88A 230V 1PH	143	C2
16.7	200-240	1	3R	PID005032NDBP	VFD NEMA 3R ND 16.7A 230V 1PH	51	B1
24.2	200-240	1	3R	PID007532NDBP	VFD NEMA 3R ND 24.2A 230V 1PH	51	B1
30.8	200-240	1	3R	PID010032NDBP	VFD NEMA 3R ND 30.8A 230V 1PH	60	B2
59.4	200-240	1	3R	PID020032NDBP	VFD NEMA 3R ND 59.4A 230V 1PH	99	C1
88	200-240	1	3R	PID030032NDBP	VFD NEMA 3R ND 88A 230V 1PH	143	C2
16.7	200-240	1	4X	PID005042NDBP	VFD NEMA 4X ND 16.7A 230V 1PH	51	B1
24.2	200-240	1	4X	PID007542NDBP	VFD NEMA 4X ND 24.2A 230V 1PH	51	B1
30.8	200-240	1	4X	PID010042NDBP	VFD NEMA 4X ND 30.8A 230V 1PH	60	B2
59.4	200-240	1	4X	PID020042NDBP	VFD NEMA 4X ND 59.4A 230V 1PH	99	C1
88	200-240	1	4X	PID030042NDBP	VFD NEMA 4X ND 88A 230V 1PH	143	C2

230V ONE-PHASE INPUT DRIVES (VARIOUS ENCLOSURES, STANDARD DISCONNECT)

OUTPUT AMPS*	INPUT VOLTAGE	INPUT PHASE	NEMA RATING	PENTAIR PART NUMBER	PART DESCRIPTION	WEIGHT	FRAME**
16.7	200-240	1	1	PID005012SD	VFD NEMA 1 SD 16.7A 230V 1PH	51	B1
24.2	200-240	1	1	PID007512SD	VFD NEMA 1 SD 24.2A 230V 1PH	51	B1
30.8	200-240	1	1	PID010012SD	VFD NEMA 1 SD 30.8A 230V 1PH	60	B2
59.4	200-240	1	1	PID020012SD	VFD NEMA 1 SD 59.4A 230V 1PH	99	C1
88	200-240	1	1	PID030012SD	VFD NEMA 1 SD 88A 230V 1PH	143	C2
16.7	200-240	1	3R	PID005032SDBP	VFD NEMA 3R SD 16.7A 230V 1PH	51	B1
24.2	200-240	1	3R	PID007532SDBP	VFD NEMA 3R SD 24.2A 230V 1PH	51	B1
30.8	200-240	1	3R	PID010032SDBP	VFD NEMA 3R SD 30.8A 230V 1PH	60	B2
59.4	200-240	1	3R	PID020032SDBP	VFD NEMA 3R SD 59.4A 230V 1PH	99	C1
88	200-240	1	3R	PID030032SDBP	VFD NEMA 3R SD 88A 230V 1PH	143	C2
16.7	200-240	1	4X	PID005042SDBP	VFD NEMA 4X SD 16.7A 230V 1PH	51	B1
24.2	200-240	1	4X	PID007542SDBP	VFD NEMA 4X SD 24.2A 230V 1PH	51	B1
30.8	200-240	1	4X	PID010042SDBP	VFD NEMA 4X SD 30.8A 230V 1PH	60	B2
59.4	200-240	1	4X	PID020042SDBP	VFD NEMA 4X SD 59.4A 230V 1PH	99	C1
88	200-240	1	4X	PID030042SDBP	VFD NEMA 4X SD 88A 230V 1PH	143	C2

*Select drives by S.F. Amps of pump motor. **See nomenclature page for dimensions.

SECTION 9: PENTEK INTELLIDRIVE™ XL PRODUCT SELECTION GUIDE

460V ONE-PHASE INPUT DRIVES (VARIOUS ENCLOSURES, NO DISCONNECT)

OUTPUT AMPS [~]	INPUT VOLTAGE	INPUT PHASE	NEMA RATING	PENTAIR PART NUMBER	PART DESCRIPTION	WEIGHT	FRAME ^{**}
14.5	380-480	1	1	PID010019ND	VFD NEMA 1 ND 14.5A 460V 1PH	51	B1
21	380-480	1	1	PID015019ND	VFD NEMA 1 ND 21A 460V 1PH	60	B2
34	380-480	1	1	PID025019ND	VFD NEMA 1 ND 34A 460V 1PH	99	C1
65	380-480	1	1	PID050019ND	VFD NEMA 1 ND 65A 460V 1PH	143	C2
14.5	380-480	1	3R	PID010039NDBP	VFD NEMA 3R ND 14.5A 460V 1PH	51	B1
21	380-480	1	3R	PID015039NDBP	VFD NEMA 3R ND 21A 460V 1PH	60	B2
34	380-480	1	3R	PID025039NDBP	VFD NEMA 3R ND 34A 460V 1PH	99	C1
65	380-480	1	3R	PID050039NDBP	VFD NEMA 3R ND 65A 460V 1PH	143	C2
14.5	380-480	1	4X	PID010049NDBP	VFD NEMA 4X ND 14.5A 460V 1PH	51	B1
21	380-480	1	4X	PID015049NDBP	VFD NEMA 4X ND 21A 460V 1PH	60	B2
34	380-480	1	4X	PID025049NDBP	VFD NEMA 4X ND 34A 460V 1PH	99	C1
65	380-480	1	4X	PID050049NDBP	VFD NEMA 4X ND 65A 460V 1PH	143	C2

NEMA 1 ENCLOSURE (NO DISCONNECT)

OUTPUT AMPS [~]	INPUT VOLTAGE	INPUT PHASE	PENTAIR PART NUMBER	PART DESCRIPTION	WEIGHT	FRAME ^{**}
4.6	200-240	3	PID001013ND	VFD NEMA 1 ND 4.6A 230V 3PH	11	A2
7.5	200-240	3	PID002013ND	VFD NEMA 1 ND 7.5A 230V 3PH	11	A2
10.6	200-240	3	PID003013ND	VFD NEMA 1 ND 10.6A 230V 3PH	11	A2
16.7	200-240	3	PID005013ND	VFD NEMA 1 ND 16.7A 230V 3PH	15	A3
24.2	200-240	3	PID007513ND	VFD NEMA 1 ND 24.2A 230V 3PH	51	B1
30.8	200-240	3	PID010013ND	VFD NEMA 1 ND 30.8A 230V 3PH	51	B1
46.2	200-240	3	PID015013ND	VFD NEMA 1 ND 46.2A 230V 3PH	51	B1
59.4	200-240	3	PID020013ND	VFD NEMA 1 ND 59.4A 230V 3PH	53	B4
74.8	200-240	3	PID025013ND	VFD NEMA 1 ND 74.8A 230V 3PH	99	C1
88	200-240	3	PID030013ND	VFD NEMA 1 ND 88A 230V 3PH	99	C1
115	200-240	3	PID040013ND	VFD NEMA 1 ND 115A 230V 3PH	99	C1
143	200-240	3	PID050013ND	VFD NEMA 1 ND 143A 230V 3PH	110	C4
170	200-240	3	PID060013ND	VFD NEMA 1 ND 170A 230V 3PH	110	C4
2.1	380-480	3	PID001014ND	VFD NEMA 1 ND 2.1A 460V 3PH	11	A2
3.4	380-480	3	PID002014ND	VFD NEMA 1 ND 3.4A 460V 3PH	11	A2
4.8	380-480	3	PID003014ND	VFD NEMA 1 ND 4.8A 460V 3PH	11	A2
8.2	380-480	3	PID005014ND	VFD NEMA 1 ND 8.2A 460V 3PH	11	A2
11	380-480	3	PID007514ND	VFD NEMA 1 ND 11A 460V 3PH	15	A3
14.5	380-480	3	PID010014ND	VFD NEMA 1 ND 14.5A 460V 3PH	15	A3
21	380-480	3	PID015014ND	VFD NEMA 1 ND 21A 460V 3PH	51	B1
27	380-480	3	PID020014ND	VFD NEMA 1 ND 27A 460V 3PH	51	B1
34	380-480	3	PID025014ND	VFD NEMA 1 ND 34A 460V 3PH	51	B1
40	380-480	3	PID030014ND	VFD NEMA 1 ND 40A 460V 3PH	60	B2
52	380-480	3	PID040014ND	VFD NEMA 1 ND 52A 460V 3PH	60	B2
65	380-480	3	PID050014ND	VFD NEMA 1 ND 65A 460V 3PH	99	C1
80	380-480	3	PID060014ND	VFD NEMA 1 ND 80A 460V 3PH	99	C1
105	380-480	3	PID075014ND	VFD NEMA 1 ND 105A 460V 3PH	99	C1
130	380-480	3	PID100014ND	VFD NEMA 1 ND 130A 460V 3PH	143	C2
160	380-480	3	PID125014ND	VFD NEMA 1 ND 160A 460V 3PH	143	C2
1.7	525-600	3	PID001015ND	VFD NEMA 1 ND 1.7A 575V 3PH	11	A2
2.7	525-600	3	PID002015ND	VFD NEMA 1 ND 2.7A 575V 3PH	11	A2
3.9	525-600	3	PID003015ND	VFD NEMA 1 ND 3.9A 575V 3PH	11	A2
6.1	525-600	3	PID005015ND	VFD NEMA 1 ND 6.1A 575V 3PH	11	A2

[~]Select drives by S.F. Amps of pump motor. ^{**}See nomenclature page for dimensions.

SECTION 9: PENTEK INTELLIDRIVE™ XL PRODUCT SELECTION GUIDE

NEMA 1 ENCLOSURE (NO DISCONNECT)

OUTPUT AMPS [~]	INPUT VOLTAGE	INPUT PHASE	PENTAIR PART NUMBER	PART DESCRIPTION	WEIGHT	FRAME ^{**}
9	525-600	3	PID007515ND	VFD NEMA 1 ND 9A 575V 3PH	15	A3
11	525-600	3	PID010015ND	VFD NEMA 1 ND 11A 575V 3PH	15	A3
18	525-600	3	PID015015ND	VFD NEMA 1 ND 18A 575V 3PH	51	B1
22	525-600	3	PID020015ND	VFD NEMA 1 ND 22A 575V 3PH	51	B1
27	525-600	3	PID025015ND	VFD NEMA 1 ND 27A 575V 3PH	51	B1
34	525-600	3	PID030015ND	VFD NEMA 1 ND 34A 575V 3PH	53	B4
41	525-600	3	PID040015ND	VFD NEMA 1 ND 41A 575V 3PH	53	B4
52	525-600	3	PID050015ND	VFD NEMA 1 ND 52A 575V 3PH	53	B4
62	525-600	3	PID060015ND	VFD NEMA 1 ND 62A 575V 3PH	99	C1
83	525-600	3	PID075015ND	VFD NEMA 1 ND 83A 575V 3PH	99	C1
100	525-600	3	PID100015ND	VFD NEMA 1 ND 100A 575V 3PH	143	C2
131	525-600	3	PID125015ND	VFD NEMA 1 ND 131A 575V 3PH	229	D1h

NEMA 1 ENCLOSURE (FUSED DISCONNECT)

OUTPUT AMPS [~]	INPUT VOLTAGE	INPUT PHASE	PENTAIR PART NUMBER	PART DESCRIPTION	WEIGHT	FRAME ^{**}
4.6	200-240	3	PID001013FD	VFD NEMA 1 FD 4.6A 230V 3PH	11	A2
7.5	200-240	3	PID002013FD	VFD NEMA 1 FD 7.5A 230V 3PH	11	A2
10.6	200-240	3	PID003013FD	VFD NEMA 1 FD 10.6A 230V 3PH	11	A2
16.7	200-240	3	PID005013FD	VFD NEMA 1 FD 16.7A 230V 3PH	15	A3
24.2	200-240	3	PID007513FD	VFD NEMA 1 FD 24.2A 230V 3PH	51	B1
30.8	200-240	3	PID010013FD	VFD NEMA 1 FD 30.8A 230V 3PH	51	B1
46.2	200-240	3	PID015013FD	VFD NEMA 1 FD 46.2A 230V 3PH	51	B1
59.4	200-240	3	PID020013FD	VFD NEMA 1 FD 59.4A 230V 3PH	53	B4
74.8	200-240	3	PID025013FD	VFD NEMA 1 FD 74.8A 230V 3PH	99	C1
88	200-240	3	PID030013FD	VFD NEMA 1 FD 88A 230V 3PH	99	C1
115	200-240	3	PID040013FD	VFD NEMA 1 FD 115A 230V 3PH	99	C1
143	200-240	3	PID050013FD	VFD NEMA 1 FD 143A 230V 3PH	110	C4
170	200-240	3	PID060013FD	VFD NEMA 1 FD 170A 230V 3PH	110	C4

[~]Select drives by S.F. Amps of pump motor. ^{**}See nomenclature page for dimensions.

SECTION 9: PENTEK INTELLIDRIVE™ XL PRODUCT SELECTION GUIDE

NEMA 1 ENCLOSURE (FUSED DISCONNECT)

OUTPUT AMPS [^]	INPUT VOLTAGE	INPUT PHASE	PENTAIR PART NUMBER	PART DESCRIPTION	WEIGHT	FRAME ^{**}
2.1	380-480	3	PID001014FD	VFD NEMA 1 FD 2.1A 460V 3PH	11	A2
3.4	380-480	3	PID002014FD	VFD NEMA 1 FD 3.4A 460V 3PH	11	A2
4.8	380-480	3	PID003014FD	VFD NEMA 1 FD 4.8A 460V 3PH	11	A2
8.2	380-480	3	PID005014FD	VFD NEMA 1 FD 8.2A 460V 3PH	11	A2
11	380-480	3	PID007514FD	VFD NEMA 1 FD 11A 460V 3PH	15	A3
14.5	380-480	3	PID010014FD	VFD NEMA 1 FD 14.5A 460V 3PH	15	A3
21	380-480	3	PID015014FD	VFD NEMA 1 FD 21A 460V 3PH	51	B1
27	380-480	3	PID020014FD	VFD NEMA 1 FD 27A 460V 3PH	51	B1
34	380-480	3	PID025014FD	VFD NEMA 1 FD 34A 460V 3PH	51	B1
40	380-480	3	PID030014FD	VFD NEMA 1 FD 40A 460V 3PH	60	B2
52	380-480	3	PID040014FD	VFD NEMA 1 FD 52A 460V 3PH	60	B2
65	380-480	3	PID050014FD	VFD NEMA 1 FD 65A 460V 3PH	99	C1
80	380-480	3	PID060014FD	VFD NEMA 1 FD 80A 460V 3PH	99	C1
105	380-480	3	PID075014FD	VFD NEMA 1 FD 105A 460V 3PH	99	C1
130	380-480	3	PID100014FD	VFD NEMA 1 FD 130A 460V 3PH	143	C2
160	380-480	3	PID125014FD	VFD NEMA 1 FD 160A 460V 3PH	143	C2
190	380-480	3	PID150014FD	VFD NEMA 1 FD 190A 460V 3PH	229	D1h
240	380-480	3	PID200014FD	VFD NEMA 1 FD 240A 460V 3PH	229	D1h
302	380-480	3	PID250014FD	VFD NEMA 1 FD 302A 460V 3PH	229	D1h
361	380-480	3	PID300014FD	VFD NEMA 1 FD 361A 460V 3PH	332	D2h
443	380-480	3	PID350014FD	VFD NEMA 1 FD 443A 460V 3PH	332	D2h
540	380-480	3	PID450014FD	VFD NEMA 1 FD 540A 460V 3PH	332	D2h
590	380-480	3	PID500014FD	VFD NEMA 1 FD 590A 460V 3PH	689	E1
678	380-480	3	PID550014FD	VFD NEMA 1 FD 678A 460V 3PH	689	E1
730	380-480	3	PID600014FD	VFD NEMA 1 FD 730A 460V 3PH	689	E1

[^]Select drives by S.F. Amps of pump motor. ^{**}See nomenclature page for dimensions.

SECTION 9: PENTEK INTELLIDRIVE™ XL PRODUCT SELECTION GUIDE

NEMA 1 ENCLOSURE (FUSED DISCONNECT)

OUTPUT AMPS [^]	INPUT VOLTAGE	INPUT PHASE	PENTAIR PART NUMBER	PART DESCRIPTION	WEIGHT	FRAME ^{^^}
1.7	525-600	3	PID001015FD	VFD NEMA 1 FD 1.7A 575V 3PH	11	A2
2.7	525-600	3	PID002015FD	VFD NEMA 1 FD 2.7A 575V 3PH	11	A2
3.9	525-600	3	PID003015FD	VFD NEMA 1 FD 3.9A 575V 3PH	11	A2
6.1	525-600	3	PID005015FD	VFD NEMA 1 FD 6.1A 575V 3PH	11	A2
9	525-600	3	PID007515FD	VFD NEMA 1 FD 9A 575V 3PH	15	A3
11	525-600	3	PID010015FD	VFD NEMA 1 FD 11A 575V 3PH	15	A3
18	525-600	3	PID015015FD	VFD NEMA 1 FD 18A 575V 3PH	51	B1
22	525-600	3	PID020015FD	VFD NEMA 1 FD 22A 575V 3PH	51	B1
27	525-600	3	PID025015FD	VFD NEMA 1 FD 27A 575V 3PH	51	B1
34	525-600	3	PID030015FD	VFD NEMA 1 FD 34A 575V 3PH	53	B4
41	525-600	3	PID040015FD	VFD NEMA 1 FD 41A 575V 3PH	53	B4
52	525-600	3	PID050015FD	VFD NEMA 1 FD 52A 575V 3PH	53	B4
62	525-600	3	PID060015FD	VFD NEMA 1 FD 62A 575V 3PH	99	C1
83	525-600	3	PID075015FD	VFD NEMA 1 FD 83A 575V 3PH	99	C1
100	525-600	3	PID100015FD	VFD NEMA 1 FD 100A 575V 3PH	143	C2
131	525-600	3	PID125015FD	VFD NEMA 1 FD 131A 575V 3PH	229	D1h
155	525-600	3	PID150015FD	VFD NEMA 1 FD 155A 575V 3PH	22	D1h
192	525-600	3	PID200015FD	VFD NEMA 1 FD 192A 575V 3PH	229	D1h
242	525-600	3	PID250015FD	VFD NEMA 1 FD 242A 575V 3PH	332	D2h
290	525-600	3	PID300015FD	VFD NEMA 1 FD 290A 575V 3PH	332	D2h
344	525-600	3	PID350015FD	VFD NEMA 1 FD 344A 575V 3PH	332	D2h
450	525-600	3	PID450015FD	VFD NEMA 1 FD 450A 575V 3PH	689	E1
500	525-600	3	PID500015FD	VFD NEMA 1 FD 500A 575V 3PH	689	E1
570	525-600	3	PID560015FD	VFD NEMA 1 FD 570A 575V 3PH	689	E1
630	525-600	3	PID630015FD	VFD NEMA 1 FD 630A 575V 3PH	689	E1

[^]Select drives by S.F. Amps of pump motor. ^{^^}See nomenclature page for dimensions.

SECTION 9: PENTEK INTELLIDRIVE™ XL PRODUCT SELECTION GUIDE

NEMA 12 ENCLOSURE (FUSED DISCONNECT)

OUTPUT AMPS [~]	INPUT VOLTAGE	INPUT PHASE	PENTAIR PART NUMBER	PART DESCRIPTION	WEIGHT	FRAME ^{**}
190	380-480	3	PID150024FD	VFD NEMA 12 FD 190A 460V 3PH	229	D1h
240	380-480	3	PID200024FD	VFD NEMA 12 FD 240A 460V 3PH	229	D1h
302	380-480	3	PID250024FD	VFD NEMA 12 FD 302A 460V 3PH	229	D1h
361	380-480	3	PID300024FD	VFD NEMA 12 FD 361A 460V 3PH	332	D2h
443	380-480	3	PID350024FD	VFD NEMA 12 FD 443A 460V 3PH	332	D2h
540	380-480	3	PID450024FD	VFD NEMA 12 FD 540A 460V 3PH	332	D2h
590	380-480	3	PID500024FD	VFD NEMA 12 FD 590A 460V 3PH	689	E1
678	380-480	3	PID550024FD	VFD NEMA 12 FD 678A 460V 3PH	689	E1
730	380-480	3	PID600024FD	VFD NEMA 12 FD 730A 460V 3PH	689	E1
155	525-600	3	PID150025FD	VFD NEMA 12 FD 155A 575V 3PH	229	D1h
192	525-600	3	PID200025FD	VFD NEMA 12 FD 192A 575V 3PH	229	D1h
242	525-600	3	PID250025FD	VFD NEMA 12 FD 242A 575V 3PH	332	D2h
290	525-600	3	PID300025FD	VFD NEMA 12 FD 290A 575V 3PH	332	D2h
344	525-600	3	PID350025FD	VFD NEMA 12 FD 344A 575V 3PH	332	D2h
450	525-600	3	PID450025FD	VFD NEMA 12 FD 450A 575V 3PH	689	E1
500	525-600	3	PID500025FD	VFD NEMA 12 FD 500A 575V 3PH	689	E1
570	525-600	3	PID560025FD	VFD NEMA 12 FD 570A 575V 3PH	689	E1
630	525-600	3	PID630025FD	VFD NEMA 12 FD 630A 575V 3PH	689	E1

[~]Select drives by S.F. amps of pump motor. ^{**}See nomenclature page for dimensions.

SECTION 9: PENTEK INTELLIDRIVE™ XL PRODUCT SELECTION GUIDE

NEMA 3R ENCLOSURE (NO DISCONNECT)

OUTPUT AMPS ^ˆ	INPUT VOLTAGE	INPUT PHASE	PENTAIR PART NUMBER	PART DESCRIPTION	WEIGHT	FRAME ^{ˆˆ}
4.6	200-240	3	PID001033NDBP	VFD NEMA 3R ND 4.6A 230V 3PH	24	A4
7.5	200-240	3	PID002033NDBP	VFD NEMA 3R ND 7.5A 230V 3PH	24	A4
10.6	200-240	3	PID003033NDBP	VFD NEMA 3R ND 10.6A 230V 3PH	24	A4
16.7	200-240	3	PID005033NDBP	VFD NEMA 3R ND 16.7A 230V 3PH	31	A5
24.2	200-240	3	PID007533NDBP	VFD NEMA 3R ND 24.2A 230V 3PH	51	B1
30.8	200-240	3	PID010033NDBP	VFD NEMA 3R ND 30.8A 230V 3PH	51	B1
46.2	200-240	3	PID015033NDBP	VFD NEMA 3R ND 46.2A 230V 3PH	51	B1
59.4	200-240	3	PID020033NDBP	VFD NEMA 3R ND 59.4A 230V 3PH	60	B2
74.8	200-240	3	PID025033NDBP	VFD NEMA 3R ND 74.8A 230V 3PH	99	C1
88	200-240	3	PID030033NDBP	VFD NEMA 3R ND 88A 230V 3PH	99	C1
115	200-240	3	PID040033NDBP	VFD NEMA 3R ND 115A 230V 3PH	99	C1
143	200-240	3	PID050033NDBP	VFD NEMA 3R ND 143A 230V 3PH	143	C2
170	200-240	3	PID060033NDBP	VFD NEMA 3R ND 170A 230V 3PH	143	C2
2.1	380-480	3	PID001034NDBP	VFD NEMA 3R ND 2.1A 460V 3PH	24	A4
3.4	380-480	3	PID002034NDBP	VFD NEMA 3R ND 3.4A 460V 3PH	24	A4
4.8	380-480	3	PID003034NDBP	VFD NEMA 3R ND 4.8A 460V 3PH	24	A4
8.2	380-480	3	PID005034NDBP	VFD NEMA 3R ND 8.2A 460V 3PH	24	A4
11	380-480	3	PID007534NDBP	VFD NEMA 3R ND 11A 460V 3PH	31	A5
14.5	380-480	3	PID010034NDBP	VFD NEMA 3R ND 14.5A 460V 3PH	31	A5
21	380-480	3	PID015034NDBP	VFD NEMA 3R ND 21A 460V 3PH	51	B1
27	380-480	3	PID020034NDBP	VFD NEMA 3R ND 27A 460V 3PH	51	B1
34	380-480	3	PID025034NDBP	VFD NEMA 3R ND 34A 460V 3PH	51	B1
40	380-480	3	PID030034NDBP	VFD NEMA 3R ND 40A 460V 3PH	60	B2
52	380-480	3	PID040034NDBP	VFD NEMA 3R ND 52A 460V 3PH	60	B2
65	380-480	3	PID050034NDBP	VFD NEMA 3R ND 65A 460V 3PH	99	C1
80	380-480	3	PID060034NDBP	VFD NEMA 3R ND 80A 460V 3PH	99	C1
105	380-480	3	PID075034NDBP	VFD NEMA 3R ND 105A 460V 3PH	99	C1
130	380-480	3	PID100034NDBP	VFD NEMA 3R ND 130A 460V 3PH	143	C2
160	380-480	3	PID125034NDBP	VFD NEMA 3R ND 160A 460V 3PH	143	C2

^ˆSelect drives by S.F. Amps of pump motor. ^{ˆˆ}See nomenclature page for dimensions.

SECTION 9: PENTEK INTELLIDRIVE™ XL QPRODUCT SELECTION GUIDE

NEMA 3R ENCLOSURE (NO DISCONNECT)

OUTPUT AMPS [~]	INPUT VOLTAGE	INPUT PHASE	PENTAIR PART NUMBER	PART DESCRIPTION	WEIGHT	FRAME ^{**}
1.7	525-600	3	PID001035NDBP	VFD NEMA 3R ND 1.7A 575V 3PH	24	A4
2.7	525-600	3	PID002035NDBP	VFD NEMA 3R ND 2.7A 575V 3PH	24	A4
3.9	525-600	3	PID003035NDBP	VFD NEMA 3R ND 3.9A 575V 3PH	24	A4
6.1	525-600	3	PID005035NDBP	VFD NEMA 3R ND 6.1A 575V 3PH	24	A4
9	525-600	3	PID007535NDBP	VFD NEMA 3R ND 9A 575V 3PH	31	A5
11	525-600	3	PID010035NDBP	VFD NEMA 3R ND 11A 575V 3PH	31	A5
18	525-600	3	PID015035NDBP	VFD NEMA 3R ND 18A 575V 3PH	51	B1
22	525-600	3	PID020035NDBP	VFD NEMA 3R ND 22A 575V 3PH	51	B1
27	525-600	3	PID025035NDBP	VFD NEMA 3R ND 27A 575V 3PH	51	B1
34	525-600	3	PID030035NDBP	VFD NEMA 3R ND 34A 575V 3PH	60	B2
41	525-600	3	PID040035NDBP	VFD NEMA 3R ND 41A 575V 3PH	60	B2
52	525-600	3	PID050035NDBP	VFD NEMA 3R ND 52A 575V 3PH	60	B2
62	525-600	3	PID060035NDBP	VFD NEMA 3R ND 62A 575V 3PH	99	C1
83	525-600	3	PID075035NDBP	VFD NEMA 3R ND 83A 575V 3PH	99	C1
100	525-600	3	PID100035NDBP	VFD NEMA 3R ND 100A 575V 3PH	143	C2
131	525-600	3	PID125035NDBP	VFD NEMA 3R ND 131A 575V 3PH	229	D1h

[~]Select drives by S.F. Amps of pump motor. ^{**}See nomenclature page for dimensions.

SECTION 9: PENTEK INTELLIDRIVE™ XL PRODUCT SELECTION GUIDE

NEMA 3R ENCLOSURE (FUSED DISCONNECT)

OUTPUT AMPS [^]	INPUT VOLTAGE	INPUT PHASE	PENTAIR PART NUMBER	PART DESCRIPTION	WEIGHT	FRAME ^{**}
4.6	200-240	3	PID001033FDBP	VFD NEMA 3R FD 4.6A 230V 3PH	24	A4
7.5	200-240	3	PID002033FDBP	VFD NEMA 3R FD 7.5A 230V 3PH	24	A4
10.6	200-240	3	PID003033FDBP	VFD NEMA 3R FD 10.6A 230V 3PH	24	A4
16.7	200-240	3	PID005033FDBP	VFD NEMA 3R FD 16.7A 230V 3PH	31	A5
24.2	200-240	3	PID007533FDBP	VFD NEMA 3R FD 24.2A 230V 3PH	51	B1
30.8	200-240	3	PID010033FDBP	VFD NEMA 3R FD 30.8A 230V 3PH	51	B1
46.2	200-240	3	PID015033FDBP	VFD NEMA 3R FD 46.2A 230V 3PH	51	B1
59.4	200-240	3	PID020033FDBP	VFD NEMA 3R FD 59.4A 230V 3PH	60	B2
74.8	200-240	3	PID025033FDBP	VFD NEMA 3R FD 74.8A 230V 3PH	99	C1
88	200-240	3	PID030033FDBP	VFD NEMA 3R FD 88A 230V 3PH	99	C1
115	200-240	3	PID040033FDBP	VFD NEMA 3R FD 115A 230V 3PH	99	C1
143	200-240	3	PID050033FDBP	VFD NEMA 3R FD 143A 230V 3PH	143	C2
170	200-240	3	PID060033FDBP	VFD NEMA 3R FD 170A 230V 3PH	143	C2
2.1	380-480	3	PID001034FDBP	VFD NEMA 3R FD 2.1A 460V 3PH	24	A4
3.4	380-480	3	PID002034FDBP	VFD NEMA 3R FD 3.4A 460V 3PH	24	A4
4.8	380-480	3	PID003034FDBP	VFD NEMA 3R FD 4.8A 460V 3PH	24	A4
8.2	380-480	3	PID005034FDBP	VFD NEMA 3R FD 8.2A 460V 3PH	24	A4
11	380-480	3	PID007534FDBP	VFD NEMA 3R FD 11A 460V 3PH	31	A5
14.5	380-480	3	PID010034FDBP	VFD NEMA 3R FD 14.5A 460V 3PH	31	A5
21	380-480	3	PID015034FDBP	VFD NEMA 3R FD 21A 460V 3PH	51	B1
27	380-480	3	PID020034FDBP	VFD NEMA 3R FD 27A 460V 3PH	51	B1
34	380-480	3	PID025034FDBP	VFD NEMA 3R FD 34A 460V 3PH	51	B1
40	380-480	3	PID030034FDBP	VFD NEMA 3R FD 40A 460V 3PH	60	B2
52	380-480	3	PID040034FDBP	VFD NEMA 3R FD 52A 460V 3PH	60	B2
65	380-480	3	PID050034FDBP	VFD NEMA 3R FD 65A 460V 3PH	99	C1
80	380-480	3	PID060034FDBP	VFD NEMA 3R FD 80A 460V 3PH	99	C1
105	380-480	3	PID075034FDBP	VFD NEMA 3R FD 105A 460V 3PH	99	C1
130	380-480	3	PID100034FDBP	VFD NEMA 3R FD 130A 460V 3PH	143	C2
160	380-480	3	PID125034FDBP	VFD NEMA 3R FD 160A 460V 3PH	143	C2

[^]Select drives by S.F. Amps of pump motor. ^{**}See nomenclature page for dimensions.

SECTION 9: PENTEK INTELLIDRIVE™ XL PRODUCT SELECTION GUIDE

NEMA 3R ENCLOSURE (FUSED DISCONNECT)

OUTPUT AMPS [^]	INPUT VOLTAGE	INPUT PHASE	PENTAIR PART NUMBER	PART DESCRIPTION	WEIGHT	FRAME ^{^^}
1.7	525-600	3	PID001035FDBP	VFD NEMA 3R FD 1.7A 575V 3PH	24	A4
2.7	525-600	3	PID002035FDBP	VFD NEMA 3R FD 2.7A 575V 3PH	24	A4
3.9	525-600	3	PID003035FDBP	VFD NEMA 3R FD 3.9A 575V 3PH	24	A4
6.1	525-600	3	PID005035FDBP	VFD NEMA 3R FD 6.1A 575V 3PH	24	A4
9	525-600	3	PID007535FDBP	VFD NEMA 3R FD 9A 575V 3PH	31	A5
11	525-600	3	PID010035FDBP	VFD NEMA 3R FD 11A 575V 3PH	31	A5
18	525-600	3	PID015035FDBP	VFD NEMA 3R FD 18A 575V 3PH	51	B1
22	525-600	3	PID020035FDBP	VFD NEMA 3R FD 22A 575V 3PH	51	B1
27	525-600	3	PID025035FDBP	VFD NEMA 3R FD 27A 575V 3PH	51	B1
34	525-600	3	PID030035FDBP	VFD NEMA 3R FD 34A 575V 3PH	60	B2
41	525-600	3	PID040035FDBP	VFD NEMA 3R FD 41A 575V 3PH	60	B2
52	525-600	3	PID050035FDBP	VFD NEMA 3R FD 52A 575V 3PH	60	B2
62	525-600	3	PID060035FDBP	VFD NEMA 3R FD 62A 575V 3PH	99	C1
83	525-600	3	PID075035FDBP	VFD NEMA 3R FD 83A 575V 3PH	99	C1
100	525-600	3	PID100035FDBP	VFD NEMA 3R FD 100A 575V 3PH	143	C2
131	525-600	3	PID125035FDBP	VFD NEMA 3R FD 131A 575V 3PH	229	D1h

[^]Select drives by S.F. Amps of pump motor. ^{^^}See nomenclature page for dimensions.

SECTION 9: PENTEK INTELLIDRIVE™ XL PRODUCT SELECTION GUIDE

NEMA 4X ENCLOSURE (NO DISCONNECT)

OUTPUT AMPS [~]	INPUT VOLTAGE	INPUT PHASE	PENTAIR PART NUMBER	PART DESCRIPTION	WEIGHT	FRAME ^{**}
4.6	200-240	3	PID001043NDBP	VFD NEMA 4X ND 4.6A 230V 3PH	24	A4
7.5	200-240	3	PID002043NDBP	VFD NEMA 4X ND 7.5A 230V 3PH	24	A4
10.6	200-240	3	PID003043NDBP	VFD NEMA 4X ND 10.6A 230V 3PH	24	A4
16.7	200-240	3	PID005043NDBP	VFD NEMA 4X ND 16.7A 230V 3PH	31	A5
24.2	200-240	3	PID007543NDBP	VFD NEMA 4X ND 24.2A 230V 3PH	51	B1
30.8	200-240	3	PID010043NDBP	VFD NEMA 4X ND 30.8A 230V 3PH	51	B1
46.2	200-240	3	PID015043NDBP	VFD NEMA 4X ND 46.2A 230V 3PH	51	B1
59.4	200-240	3	PID020043NDBP	VFD NEMA 4X ND 59.4A 230V 3PH	60	B2
74.8	200-240	3	PID025043NDBP	VFD NEMA 4X ND 74.8A 230V 3PH	99	C1
88	200-240	3	PID030043NDBP	VFD NEMA 4X ND 88A 230V 3PH	99	C1
115	200-240	3	PID040043NDBP	VFD NEMA 4X ND 115A 230V 3PH	99	C1
143	200-240	3	PID050043NDBP	VFD NEMA 4X ND 143A 230V 3PH	143	C2
170	200-240	3	PID060043NDBP	VFD NEMA 4X ND 170A 230V 3PH	143	C2
2.1	380-480	3	PID001044NDBP	VFD NEMA 4X ND 2.1A 460V 3PH	24	A4
3.4	380-480	3	PID002044NDBP	VFD NEMA 4X ND 3.4A 460V 3PH	24	A4
4.8	380-480	3	PID003044NDBP	VFD NEMA 4X ND 4.8A 460V 3PH	24	A4
8.2	380-480	3	PID005044NDBP	VFD NEMA 4X ND 8.2A 460V 3PH	24	A4
11	380-480	3	PID007544NDBP	VFD NEMA 4X ND 11A 460V 3PH	31	A5
14.5	380-480	3	PID010044NDBP	VFD NEMA 4X ND 14.5A 460V 3PH	31	A5
21	380-480	3	PID015044NDBP	VFD NEMA 4X ND 21A 460V 3PH	51	B1
27	380-480	3	PID020044NDBP	VFD NEMA 4X ND 27A 460V 3PH	51	B1
34	380-480	3	PID025044NDBP	VFD NEMA 4X ND 34A 460V 3PH	51	B1
40	380-480	3	PID030044NDBP	VFD NEMA 4X ND 40A 460V 3PH	60	B2
52	380-480	3	PID040044NDBP	VFD NEMA 4X ND 52A 460V 3PH	60	B2
65	380-480	3	PID050044NDBP	VFD NEMA 4X ND 65A 460V 3PH	99	C1
80	380-480	3	PID060044NDBP	VFD NEMA 4X ND 80A 460V 3PH	99	C1
105	380-480	3	PID075044NDBP	VFD NEMA 4X ND 105A 460V 3PH	99	C1
130	380-480	3	PID100044NDBP	VFD NEMA 4X ND 130A 460V 3PH	143	C2
160	380-480	3	PID125044NDBP	VFD NEMA 4X ND 160A 460V 3PH	143	C2

[~]Select drives by S.F. Amps of pump motor. ^{**}See nomenclature page for dimensions.

SECTION 9: PENTEK INTELLIDRIVE™ XL PRODUCT SELECTION GUIDE

NEMA 4X ENCLOSURE (NO DISCONNECT)

OUTPUT AMPS [^]	INPUT VOLTAGE	INPUT PHASE	PENTAIR PART NUMBER	PART DESCRIPTION	WEIGHT	FRAME ^{**}
1.7	525-600	3	PID001045NDBP	VFD NEMA 4X ND 1.7A 575V 3PH	24	A4
2.7	525-600	3	PID002045NDBP	VFD NEMA 4X ND 2.7A 575V 3PH	24	A4
3.9	525-600	3	PID003045NDBP	VFD NEMA 4X ND 3.9A 575V 3PH	24	A4
6.1	525-600	3	PID005045NDBP	VFD NEMA 4X ND 6.1A 575V 3PH	24	A4
9	525-600	3	PID007545NDBP	VFD NEMA 4X ND 9A 575V 3PH	31	A5
11	525-600	3	PID010045NDBP	VFD NEMA 4X ND 11A 575V 3PH	31	A5
18	525-600	3	PID015045NDBP	VFD NEMA 4X ND 18A 575V 3PH	51	B1
22	525-600	3	PID020045NDBP	VFD NEMA 4X ND 22A 575V 3PH	51	B1
27	525-600	3	PID025045NDBP	VFD NEMA 4X ND 27A 575V 3PH	51	B1
34	525-600	3	PID030045NDBP	VFD NEMA 4X ND 34A 575V 3PH	60	B2
41	525-600	3	PID040045NDBP	VFD NEMA 4X ND 41A 575V 3PH	60	B2
52	525-600	3	PID050045NDBP	VFD NEMA 4X ND 52A 575V 3PH	60	B2
62	525-600	3	PID060045NDBP	VFD NEMA 4X ND 62A 575V 3PH	99	C1
83	525-600	3	PID075045NDBP	VFD NEMA 4X ND 83A 575V 3PH	99	C1
100	525-600	3	PID100045NDBP	VFD NEMA 4X ND 100A 575V 3PH	143	C2
131	525-600	3	PID125045NDBP	VFD NEMA 4X ND 131A 575V 3PH	143	C2

[^]Select drives by S.F. Amps of pump motor. ^{**}See nomenclature page for dimensions.

SECTION 9: PENTEK INTELLIDRIVE™ XL PRODUCT SELECTION GUIDE

NEMA 4X ENCLOSURE (FUSED DISCONNECT)

OUTPUT AMPS ^ˆ	INPUT VOLTAGE	INPUT PHASE	PENTAIR PART NUMBER	PART DESCRIPTION	WEIGHT	FRAME ^{ˆˆ}
4.6	200-240	3	PID001043FDBP	VFD NEMA 4X FD 4.6A 230V 3PH	24	A4
7.5	200-240	3	PID002043FDBP	VFD NEMA 4X FD 7.5A 230V 3PH	24	A4
10.6	200-240	3	PID003043FDBP	VFD NEMA 4X FD 10.6A 230V 3PH	24	A4
16.7	200-240	3	PID005043FDBP	VFD NEMA 4X FD 16.7A 230V 3PH	31	A5
24.2	200-240	3	PID007543FDBP	VFD NEMA 4X FD 24.2A 230V 3PH	51	B1
30.8	200-240	3	PID010043FDBP	VFD NEMA 4X FD 30.8A 230V 3PH	51	B1
46.2	200-240	3	PID015043FDBP	VFD NEMA 4X FD 46.2A 230V 3PH	51	B1
59.4	200-240	3	PID020043FDBP	VFD NEMA 4X FD 59.4A 230V 3PH	60	B2
74.8	200-240	3	PID025043FDBP	VFD NEMA 4X FD 74.8A 230V 3PH	99	C1
88	200-240	3	PID030043FDBP	VFD NEMA 4X FD 88A 230V 3PH	99	C1
115	200-240	3	PID040043FDBP	VFD NEMA 4X FD 115A 230V 3PH	99	C1
143	200-240	3	PID050043FDBP	VFD NEMA 4X FD 143A 230V 3PH	143	C2
170	200-240	3	PID060043FDBP	VFD NEMA 4X FD 170A 230V 3PH	143	C2
2.1	380-480	3	PID001044FDBP	VFD NEMA 4X FD 2.1A 460V 3PH	24	A4
3.4	380-480	3	PID002044FDBP	VFD NEMA 4X FD 3.4A 460V 3PH	24	A4
4.8	380-480	3	PID003044FDBP	VFD NEMA 4X FD 4.8A 460V 3PH	24	A4
8.2	380-480	3	PID005044FDBP	VFD NEMA 4X FD 8.2A 460V 3PH	24	A4
11	380-480	3	PID007544FDBP	VFD NEMA 4X FD 11A 460V 3PH	31	A5
14.5	380-480	3	PID010044FDBP	VFD NEMA 4X FD 14.5A 460V 3PH	31	A5
21	380-480	3	PID015044FDBP	VFD NEMA 4X FD 21A 460V 3PH	51	B1
27	380-480	3	PID020044FDBP	VFD NEMA 4X FD 27A 460V 3PH	51	B1
34	380-480	3	PID025044FDBP	VFD NEMA 4X FD 34A 460V 3PH	51	B1
40	380-480	3	PID030044FDBP	VFD NEMA 4X FD 40A 460V 3PH	60	B2
52	380-480	3	PID040044FDBP	VFD NEMA 4X FD 52A 460V 3PH	60	B2
65	380-480	3	PID050044FDBP	VFD NEMA 4X FD 65A 460V 3PH	99	C1
80	380-480	3	PID060044FDBP	VFD NEMA 4X FD 80A 460V 3PH	99	C1
105	380-480	3	PID075044FDBP	VFD NEMA 4X FD 105A 460V 3PH	99	C1
130	380-480	3	PID100044FDBP	VFD NEMA 4X FD 130A 460V 3PH	143	C2
160	380-480	3	PID125044FDBP	VFD NEMA 4X FD 160A 460V 3PH	143	C2

^ˆSelect drives by S.F. Amps of pump motor. ^{ˆˆ}See nomenclature page for dimensions.

SECTION 9: PENTEK INTELLIDRIVE™ XL PRODUCT SELECTION GUIDE

NEMA 4X ENCLOSURE (FUSED DISCONNECT)

OUTPUT AMPS [^]	INPUT VOLTAGE	INPUT PHASE	PENTAIR PART NUMBER	PART DESCRIPTION	WEIGHT	FRAME ^{^^}
1.7	525-600	3	PID001045FDBP	VFD NEMA 4X FD 1.7A 575V 3PH	24	A4
2.7	525-600	3	PID002045FDBP	VFD NEMA 4X FD 2.7A 575V 3PH	24	A4
3.9	525-600	3	PID003045FDBP	VFD NEMA 4X FD 3.9A 575V 3PH	24	A4
6.1	525-600	3	PID005045FDBP	VFD NEMA 4X FD 6.1A 575V 3PH	24	A4
9	525-600	3	PID007545FDBP	VFD NEMA 4X FD 9A 575V 3PH	31	A5
11	525-600	3	PID010045FDBP	VFD NEMA 4X FD 11A 575V 3PH	31	A5
18	525-600	3	PID015045FDBP	VFD NEMA 4X FD 18A 575V 3PH	51	B1
22	525-600	3	PID020045FDBP	VFD NEMA 4X FD 22A 575V 3PH	51	B1
27	525-600	3	PID025045FDBP	VFD NEMA 4X FD 27A 575V 3PH	51	B1
34	525-600	3	PID030045FDBP	VFD NEMA 4X FD 34A 575V 3PH	60	B2
41	525-600	3	PID040045FDBP	VFD NEMA 4X FD 41A 575V 3PH	60	B2
52	525-600	3	PID050045FDBP	VFD NEMA 4X FD 52A 575V 3PH	60	B2
62	525-600	3	PID060045FDBP	VFD NEMA 4X FD 62A 575V 3PH	99	C1
83	525-600	3	PID075045FDBP	VFD NEMA 4X FD 83A 575V 3PH	99	C1
100	525-600	3	PID100045FDBP	VFD NEMA 4X FD 100A 575V 3PH	143	C2
131	525-600	3	PID125045FDBP	VFD NEMA 4X FD 131A 575V 3PH	143	C2

[^]Select drives by S.F. Amps of pump motor. ^{^^}See nomenclature page for dimensions.

SECTION 9: PENTEK INTELLIDRIVE™ XL PRODUCT SELECTION GUIDE

OPEN CHASSIS (IP20, NO DISCONNECT)

OUTPUT AMPS [~]	INPUT VOLTAGE	INPUT PHASE	PENTAIR PART NUMBER	PART DESCRIPTION	WEIGHT	FRAME ^{**}
4.6	200-240	3	PID001003ND	VFD OPEN ND 4.6A 230V 3PH	11	A2
7.5	200-240	3	PID002003ND	VFD OPEN ND 7.5A 230V 3PH	11	A2
10.6	200-240	3	PID003003ND	VFD OPEN ND 10.6A 230V 3PH	11	A2
16.7	200-240	3	PID005003ND	VFD OPEN ND 16.7A 230V 3PH	15	A3
24.2	200-240	3	PID007503ND	VFD OPEN ND 24.2A 230V 3PH	30	B3
30.8	200-240	3	PID010003ND	VFD OPEN ND 30.8A 230V 3PH	30	B3
46.2	200-240	3	PID015003ND	VFD OPEN ND 46.2A 230V 3PH	30	B3
59.4	200-240	3	PID020003ND	VFD OPEN ND 59.4A 230V 3PH	53	B4
74.8	200-240	3	PID025003ND	VFD OPEN ND 74.8A 230V 3PH	77	C3
88	200-240	3	PID030003ND	VFD OPEN ND 88A 230V 3PH	77	C3
115	200-240	3	PID040003ND	VFD OPEN ND 115A 230V 3PH	77	C3
143	200-240	3	PID050003ND	VFD OPEN ND 143A 230V 3PH	110	C4
170	200-240	3	PID060003ND	VFD OPEN ND 170A 230V 3PH	110	C4
2.1	380-480	3	PID001004ND	VFD OPEN ND 2.1A 460V 3PH	11	A2
3.4	380-480	3	PID002004ND	VFD OPEN ND 3.4A 460V 3PH	11	A2
4.8	380-480	3	PID003004ND	VFD OPEN ND 4.8A 460V 3PH	11	A2
8.2	380-480	3	PID005004ND	VFD OPEN ND 8.2A 460V 3PH	11	A2
11	380-480	3	PID007504ND	VFD OPEN ND 11A 460V 3PH	15	A3
14.5	380-480	3	PID010004ND	VFD OPEN ND 14.5A 460V 3PH	15	A3
21	380-480	3	PID015004ND	VFD OPEN ND 21A 460V 3PH	30	B3
27	380-480	3	PID020004ND	VFD OPEN ND 27A 460V 3PH	30	B3
34	380-480	3	PID025004ND	VFD OPEN ND 34A 460V 3PH	30	B3
40	380-480	3	PID030004ND	VFD OPEN ND 40A 460V 3PH	53	B4
52	380-480	3	PID040004ND	VFD OPEN ND 52A 460V 3PH	53	B4
65	380-480	3	PID050004ND	VFD OPEN ND 65A 460V 3PH	77	C3
80	380-480	3	PID060004ND	VFD OPEN ND 80A 460V 3PH	77	C3
105	380-480	3	PID075004ND	VFD OPEN ND 105A 460V 3PH	77	C3
130	380-480	3	PID100004ND	VFD OPEN ND 130A 460V 3PH	110	C4
160	380-480	3	PID125004ND	VFD OPEN ND 160A 460V 3PH	110	C4

[~]Select drives by S.F. Amps of pump motor. ^{**}See nomenclature page for dimensions.

SECTION 9: PENTEK INTELLIDRIVE™ XL PRODUCT SELECTION GUIDE

OPEN CHASSIS (IP20, NO DISCONNECT)

OUTPUT AMPS [^]	INPUT VOLTAGE	INPUT PHASE	PENTAIR PART NUMBER	PART DESCRIPTION	WEIGHT	FRAME ^{**}
1.7	525-600	3	PID001005ND	VFD OPEN ND 1.7A 575V 3PH	11	A2
2.7	525-600	3	PID002005ND	VFD OPEN ND 2.7A 575V 3PH	11	A2
3.9	525-600	3	PID003005ND	VFD OPEN ND 3.9A 575V 3PH	11	A2
6.1	525-600	3	PID005005ND	VFD OPEN ND 6.1A 575V 3PH	11	A2
9	525-600	3	PID007505ND	VFD OPEN ND 9A 575V 3PH	15	A3
11	525-600	3	PID010005ND	VFD OPEN ND 11A 575V 3PH	15	A3
18	525-600	3	PID015005ND	VFD OPEN ND 18A 575V 3PH	30	B3
22	525-600	3	PID020005ND	VFD OPEN ND 22A 575V 3PH	30	B3
27	525-600	3	PID025005ND	VFD OPEN ND 27A 575V 3PH	30	B3
34	525-600	3	PID030005ND	VFD OPEN ND 34A 575V 3PH	53	B4
41	525-600	3	PID040005ND	VFD OPEN ND 41A 575V 3PH	53	B4
52	525-600	3	PID050005ND	VFD OPEN ND 52A 575V 3PH	53	B4
62	525-600	3	PID060005ND	VFD OPEN ND 62A 575V 3PH	77	C3
83	525-600	3	PID075005ND	VFD OPEN ND 83A 575V 3PH	77	C3
100	525-600	3	PID100005ND	VFD OPEN ND 100A 575V 3PH	110	C4
131	525-600	3	PID125005ND	VFD OPEN ND 131A 575V 3PH	110	C4

[^]Select drives by S.F. Amps of pump motor. ^{**}See nomenclature page for dimensions.

SECTION 9: PENTEK INTELLIDRIVE™ XL PRODUCT SELECTION GUIDE

9.4 VARIABLE FREQUENCY DRIVE ACCESSORIES

FILTER ENCLOSED DESIGN - 230V, 460V, OR 575V INPUT (UL LISTED)

CATALOG NUMBER	DESCRIPTION	WT. LBS.
V1K2A00	V1K2A00 TCI OPEN DV/DT FILTER 2 AMPS	11
V1K3A00	V1K3A00 TCI OPEN DV/DT FILTER 3 AMPS	11
V1K4A00	V1K4A00 TCI OPEN DV/DT FILTER 4 AMPS	11
V1K6A00	V1K6A00 TCI OPEN DV/DT FILTER 6 AMPS	11
V1K8A00	V1K8A00 TCI OPEN DV/DT FILTER 8 AMPS	11
V1K12A00	V1K12A00 TCI OPEN DV/DT FILTER 12 AMPS	11
V1K18A00	V1K18A00 TCI OPEN DV/DT FILTER 18 AMPS	15
V1K25A00	V1K25A00 TCI OPEN DV/DT FILTER 25 AMPS	15
V1K27A00	V1K27A00 TCI OPEN DV/DT FILTER 27 AMPS	15
V1K35A00	V1K35A00 TCI OPEN DV/DT FILTER 35 AMPS	23
V1K45A00	V1K45A00 TCI OPEN DV/DT FILTER 45 AMPS	23
V1K55A00	V1K55A00 TCI OPEN DV/DT FILTER 55 AMPS	23
V1K80A00	V1K80A00 TCI OPEN DV/DT FILTER 80 AMPS	29
V1K110A00	V1K110A00 TCI OPEN DV/DT FILTER 110 AMPS	68
V1K130A00	V1K130A00 TCI OPEN DV/DT FILTER 130 AMPS	83
V1K160A00	V1K160A00 TCI OPEN DV/DT FILTER 160 AMPS	83
V1K2A03	V1K2A03 TCI TYPE 3R DV/DT FILTER 2 AMPS	25
V1K3A03	V1K3A03 TCI TYPE 3R DV/DT FILTER 3 AMPS	25
V1K4A03	V1K4A03 TCI TYPE 3R DV/DT FILTER 4 AMPS	25
V1K6A03	V1K6A03 TCI TYPE 3R DV/DT FILTER 6 AMPS	25
V1K8A03	V1K8A03 TCI TYPE 3R DV/DT FILTER 8 AMPS	25
V1K12A03	V1K12A03 TCI TYPE 3R DV/DT FILTER 12 AMPS	25
V1K18A03	V1K18A03 TCI TYPE 3R DV/DT FILTER 18 AMPS	29
V1K25A03	V1K25A03 TCI TYPE 3R DV/DT FILTER 25 AMPS	29
V1K27A03	V1K27A03 TCI TYPE 3R DV/DT FILTER 27 AMPS	29
V1K35A03	V1K35A03 TCI TYPE 3R DV/DT FILTER 35 AMPS	56
V1K45A03	V1K45A03 TCI TYPE 3R DV/DT FILTER 45 AMPS	56
V1K55A03	V1K55A03 TCI TYPE 3R DV/DT FILTER 55 AMPS	56
V1K80A03	V1K80A03 TCI TYPE 3R DV/DT FILTER 80 AMPS	62
V1K110A03	V1K110A03 TCI TYPE 3R DV/DT FILTER 110 AMPS	74
V1K130A03	V1K130A03 TCI TYPE 3R DV/DT FILTER 130 AMPS	89
V1K160A03	V1K160A03 TCI TYPE 3R DV/DT FILTER 160 AMPS	99

SECTION 10: SUBMERSIBLE MOTOR CONTROLS

10.1 HOW IT WORKS

Submersible Motor Controls act as an above ground control system for your submersible motor. They provide easy access to the “brains” of your motor, so you can monitor, adjust and perform maintenance without removing the motor.

There are three main groups of motor controls. Each of these controls has a slightly different function, although all serve the main purpose of providing control for the motor.

CAPACITOR START / INDUCTION RUN (CSIR)

A CSIR control uses a starting capacitor and a switch. When voltage is first applied, the switch is closed and the start capacitor is in the circuit. This provides extra torque to bring the motor up to speed. The switch is often referred to as a potential relay. The relay's coil senses voltage across the windings. When the windings get close to full speed, they magnetize the coil and physically breaks the connection to the start windings. This takes not only the start windings out of the circuit, but the starting capacitor as well. The motor then runs on the main winding alone.

CAPACITOR START / CAPACITOR RUN (CSCR)

A CSCR control functions very similar to a CSIR control except that in addition to the starting capacitor, it also uses a running capacitor. This allows the start winding to act as an auxiliary winding during operation. This smooths out operation of the motor and provides greater efficiency and a reduction in vibration and noise.

PLUS SERIES CONTROLS

The Pentek® PLUS series controls combine a CSCR design and a control circuit to provide not only starting power to the motor, but a switch to turn the control on and off. The switch takes the form of a magnetic contactor that uses a coil that physically closes the contacts when energized. The contactor allows the installer to use a pressure switch with a lower current rating, since it is not switching the full amperage of the motor.

10.2 SPECIFICATIONS

All Pentek Submersible Motor Controls are rated for Indoor or Outdoor use and employ NEMA 3R enclosures. They are rain-tight and resistant to weathering and corrosion.

The controls are rated for operation in temperatures up to 50° C (122° F). DO NOT locate the control box in direct sunlight.

The terminals can accept up to #4 AWG copper wire rated for at least 75° C. Internal wiring conforms to appliance wiring standards UL 1015 which is resistant to acids, oils, alkalies, moisture and fungus.

Pentek Submersible Motor controls are agency recognized and tested to rigorous safety standards.

For specific ratings of individual components please see the repair parts portion of the manual.

10.3 MOUNTING AND INSTALLATION

- ◆ Mount the control boxes to a secure backing.
- ◆ Mount controls vertical and plumb.
- ◆ In order to maintain NEMA 3R, plug all unused openings.

SECTION 10: SUBMERSIBLE MOTOR CONTROLS

60 HZ.

10.4 WIRING CONNECTIONS AND REPLACEMENT PARTS

1/2 TO 1 HP CAPACITOR START, INDUCTION RUN

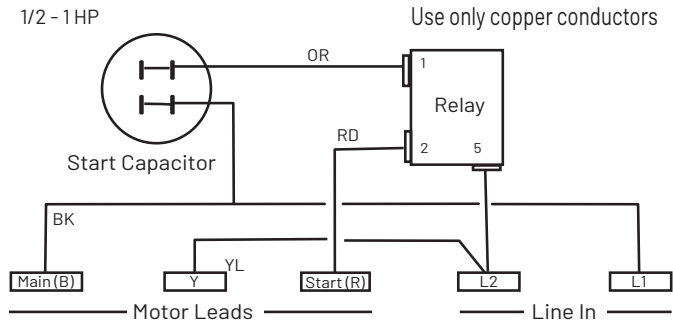

Models SMC-IR0511, SMC-IR0521, SMC-IR0721 and SMC-IR1021

HP	DESCRIPTION	PART NUMBER
1/2	Start Capacitor, 250 μ F, 125v	U17-1429-R
1/2	Start Capacitor, 59 μ F, 330v	U17-2073-R
3/4	Start Capacitor, 86 μ F, 330v	U17-2074-R
1	Start Capacitor, 105 μ F, 330v	U17-2065-R
230V	Relay	U17-1592

1/2 TO 1 HP CAPACITOR START, CAPACITOR RUN

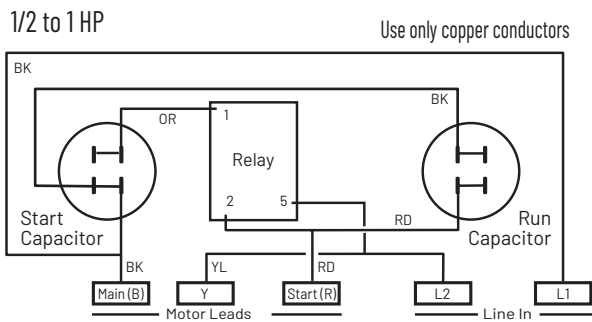

Models SMC-CR0521, SMC-CR0721, and SMC-CR1021

HP	DESCRIPTION	PART NUMBER
1/2	Start Capacitor, 45 μ F, 330v	U17-2072-R
3/4	Start Capacitor, 59 μ F, 330v	U17-2073-R
1	Start Capacitor, 86 μ F, 330v	U17-2074-R
1/2	Run Capacitor, 15 μ F, 370v	U17-1419-R
3/4	Run Capacitor, 23 μ F, 370v	U17-1292-R
1	Run Capacitor, 23 μ F, 370v	U17-1292-R
All	Relay	U17-1592

1-1/2 HP CAPACITOR START, CAPACITOR RUN

Attach installation wiring to the top of the terminal strip. Schematics may show otherwise for clarity.

1.5 HP Std

Use only copper conductors

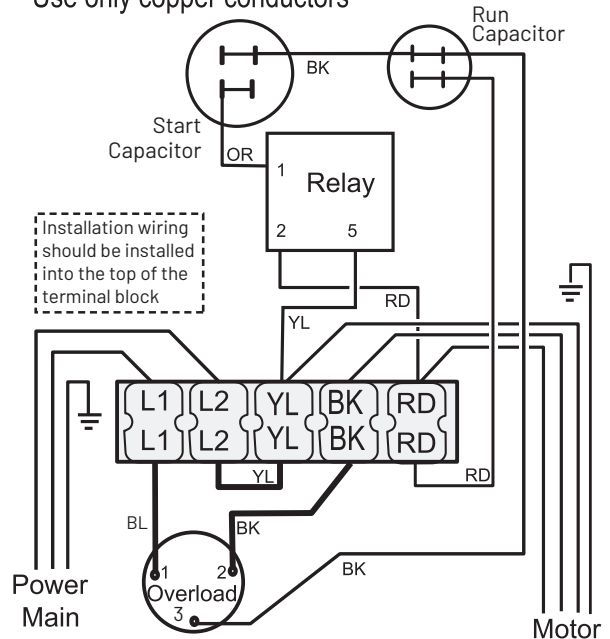

For Supply Connection, Use Wires Acceptable For At Least 75°C (167°F)

MODEL SMC-CR1521

DESCRIPTION	PART NUMBER
Overload Protector	U17-1313-R
Relay	U17-1592
Start Capacitor, 105 μ F, 330v	U17-1430-R
Run Capacitor, 10 μ F, 370v	U17-1438-R

SECTION 10: SUBMERSIBLE MOTOR CONTROLS

60 HZ.

2 AND 3 HP STANDARD

2 & 3 HP Std

Use only copper conductors

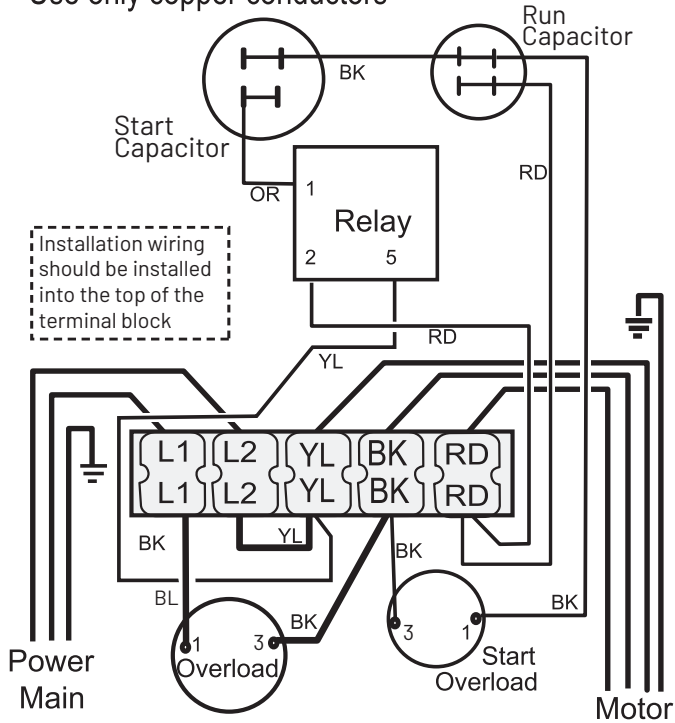

For Supply Connection, Use Wires Acceptable For At Least 75°C (167°F)

Models SMC-CR2021 and SMC-CR3021

DESCRIPTION	PART NUMBER
Start Capacitor, 105 µF, 330v, 2 HP	U17-1430-R
Start Capacitor, 208 µF, 330v, 3 HP	U17-1428-R
Run Capacitor, 20 µF, 370v, 2 HP	U17-1440-R
Run Capacitor, 45 µF, 370v, 3 HP	U17-1443-R
Main Overload Protector, 2 HP	U17-1319-R
Main Overload Protector, 3 HP	U17-1322-R
Start Overload Protector, 2 HP	U17-1320-R
Start Overload Protector, 3 HP	U17-1323-R
Relay - 2 HP	U17-1592

2 AND 3 HP PLUS

2 and 3 HP Plus

Use only copper conductors

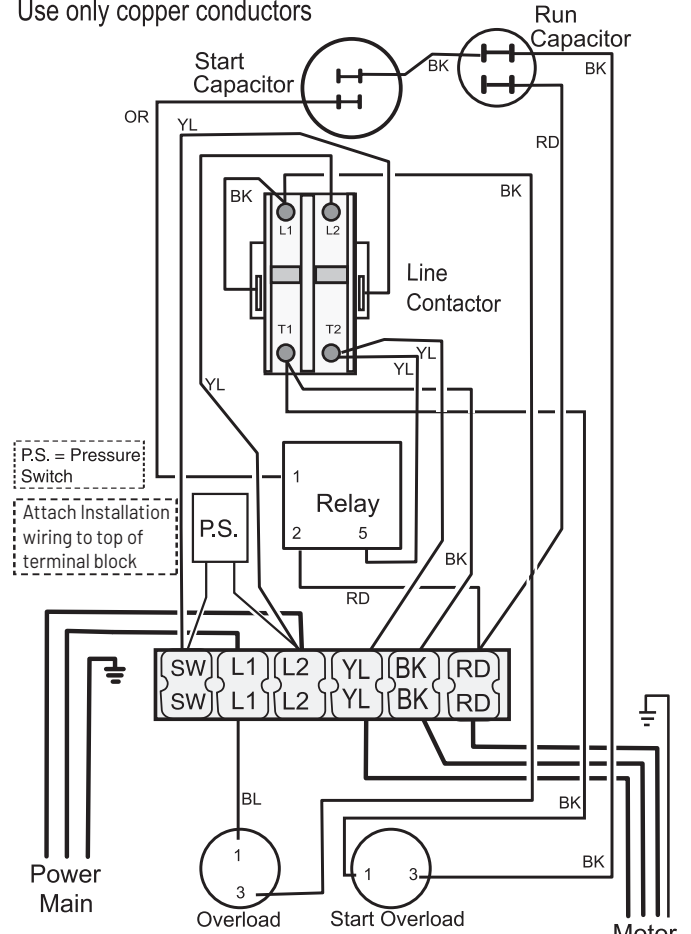

For Supply Connection, Use Wires Acceptable For At Least 75°C (167°F)

Models SMC-CRP2021 and SMC-CRP3021

DESCRIPTION	PART NUMBER
Start Capacitor, 105 µF, 330v, 2 HP	U17-1430-R
Start Capacitor, 208 µF, 330v, 3 HP	U17-1428-R
Run Capacitor, 20 µF, 370v, 2 HP	U17-1440-R
Run Capacitor, 45 µF, 370v, 3 HP	U17-1443-R
Main Overload Protector, 2 HP	U17-1319-R
Main Overload Protector, 3 HP	U17-1322-R
Start Overload Protector, 2 HP	U17-1320-R
Start Overload Protector, 3 HP	U17-1323-R
Relay - 2 HP	U17-1592
Magnetic Contactor	P17-954-R

SECTION 10: SUBMERSIBLE MOTOR CONTROLS

60 HZ.

5 HP STANDARD

5 HP Std

Use only copper conductors

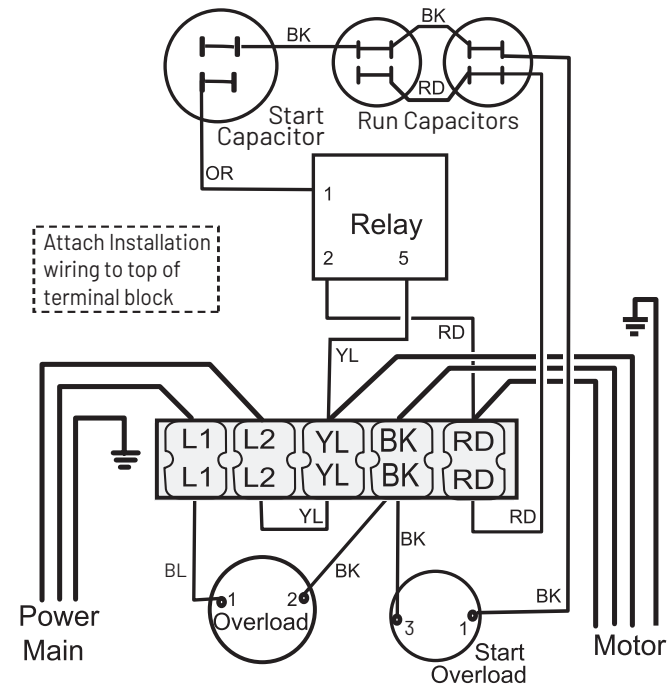

For Supply Connection, Use Wires Acceptable For At Least 75°C (167°F)

Model SMC-CR5021

DESCRIPTION	PART NUMBER
Start Capacitors, 270 µF, 330v	U17-1437-R
Run Capacitor, 80 µF, 370v	U17-1502-R
Main Overload Protector	U117-1456A-R
Start Overload Protector	U17-1321-R

5 HP PLUS

5 HP Plus

Use only copper conductors

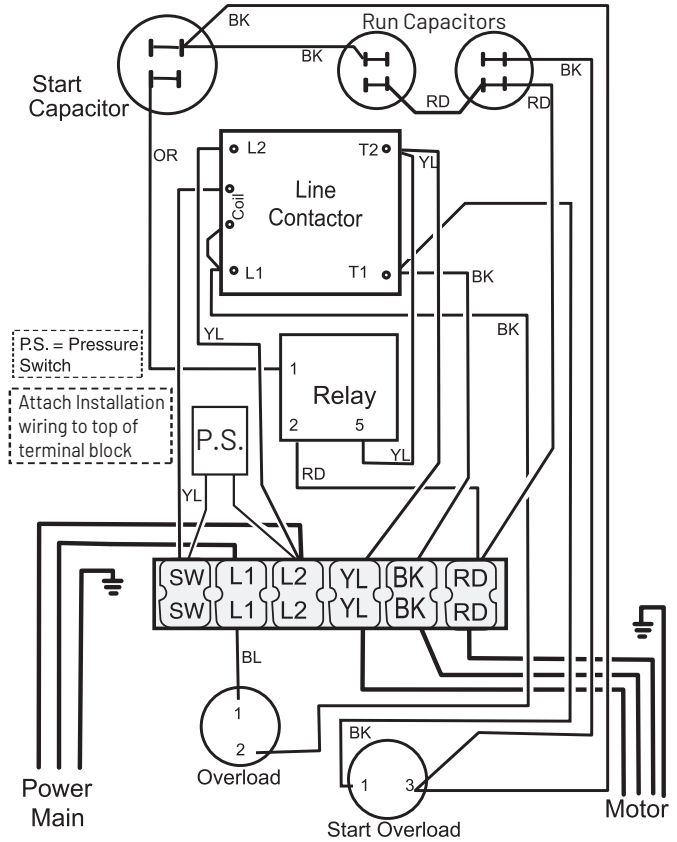

For Supply Connection, Use Wires Acceptable For At Least 75°C (167°F)

Model SMC-CRP5021

DESCRIPTION	PART NUMBER
Start Capacitors, 270 µF, 330v	U17-1437-R
Run Capacitor, (2) 40 µF, 370v	U17-1442-R
Magnetic Contactor	P17-953-R
Main Overload Protector	U117-1456B-R
Start Overload Protector	U17-1321-R

SECTION 10: SUBMERSIBLE MOTOR CONTROLS

VIP PRO SERIES 4" SINGLE-PHASE CONTROL BOXES

SIZE A

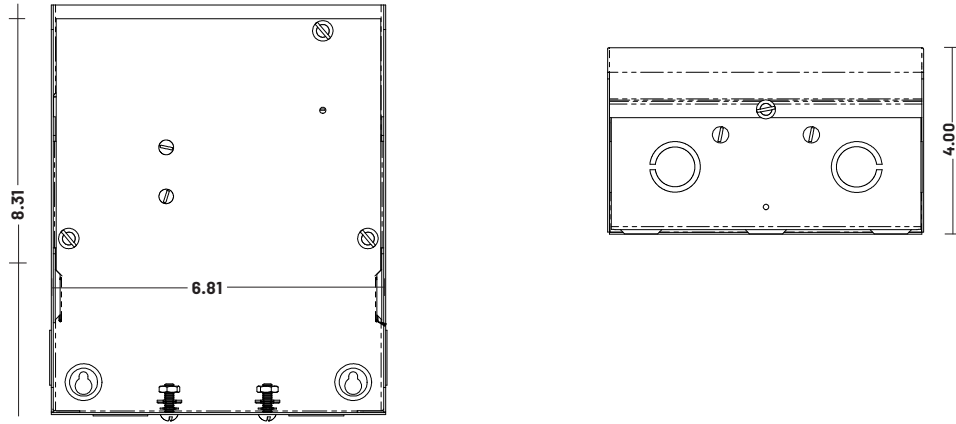

SIZE B

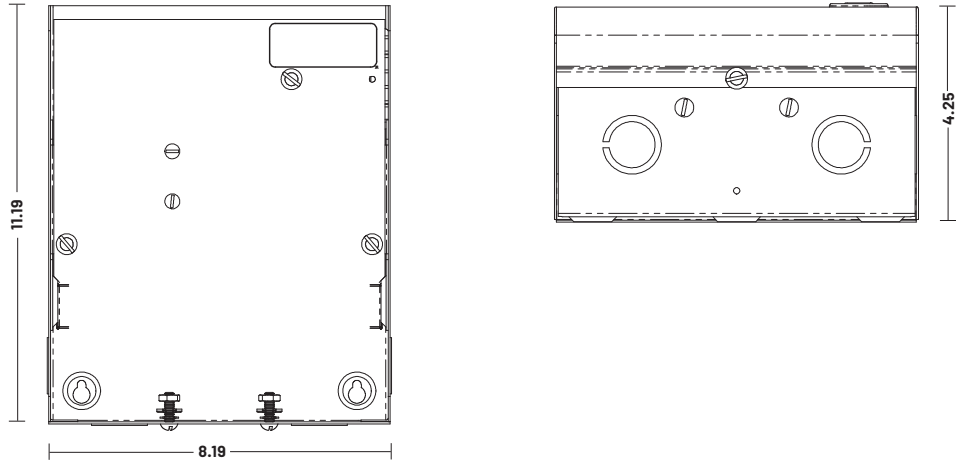

VIP CONTROL BOX SPECIFICATION

CATALOG NUMBER	HP	KW	PHASE	VOLTS	HERTZ	TYPE	WEIGHT		ENCLOSURE SIZE	START CAPACITOR		RUN CAPACITOR		VOLTAGE RELAY
							LBS	KG		PN	RATING	PN	RATING	
VIP4C02	1/2	0.37	1	230	60	CSCR	4.6	2.1	A	U17-2072-R	43MFD-330V-15kΩ	U17-1419-R	15MFD-370V	U17-2077-R
VIP4D02	3/4	0.55	1	230	60	CSCR	4.4	2.0	A	U17-2073-R	59MFD-330V-15kΩ	U17-1292-R	23MFD-370V	U17-2077-R
VIP4E02	1	0.75	1	230	60	CSCR	4.4	2.0	A	U17-2074-R	86MFD-330V-15kΩ	U17-1292-R	23MFD-370V	U17-2077-R
VIP4F02	1-1/2	1.1	1	230	60	CSCR	4.6	2.1	A	U17-1430-R	105MFD-330V-15kΩ	U17-1438-R	10MFD-370V	U17-2078-R
VIP4G02	2	1.5	1	230	60	CSCR	4.6	2.1	A	U17-1430-R	105MFD-330V-15kΩ	U17-1440-R	20MFD-370V	U17-1431-R

Control boxes are designed to be used on Pentair motors with the same HP and Voltage ratings. Do not use on motors with different ratings.

SECTION 11: MOTOR PROTECTIVE DEVICES - 50/60 HZ

11.1 HOW THEY WORK

Pentek® motor protectors are designed to protect single phase pumps from dry run, dead head, jammed impeller, and over & under voltage conditions.

A calibration adjustment allows the motor protector to be calibrated to specific pumping applications, thereby reducing the possibility of false or nuisance tripping. A micro drive based voltage and current sensing circuit monitors for power fluctuations, over-current, and under-current conditions. When an abnormality, such as loss of suction, is detected, the motor protector deactivates its output relay and immediately disconnects the pump motor. The motor protector then

activates its user-selectable “Restart Delay” (Dry run recovery) timer. When the timer counts to zero or power is removed and reapplied, the motor protector reactivates its output relay and turns the pump back on.

An infrared LED communicates directly with a hand-held diagnostics tool called the Informer (sold separately). The Informer displays 16 parameters including calibration point, trip point, running points, and last fault.

The use of flow restrictors or unusually high head pressures at the time of calibration may interfere with the detection of dead head conditions.

11.2 SPECIFICATIONS

PARAMETER	SPP-111P	SPP-111P-3RL	SPP-231P	SPP-233P	SPP-235P-XX
1 Phase Line Voltage (±10%)	115 VAC		230 VAC		
Load Range	1/3 - 1/2 HP (.25 - .37 kW)	1/3 - 1HP (.33-.75 kW)	1/3 - 1HP (.25 - .75 kW)	1/3 - 3 HP .25 - 2.24 kW)	5 - 15 HP (3.73 - 11.19 kW)
Frequency	50-60 Hz				
Power Consumption (Maximum)	5 W				
Operating Temperature	-40° to 158° F (-40° to +70° C)				
Electrostatic Discharge (ESD)	IEC 1000-4-2, Level 2, 4kV Contact, 6 kV Air				
Output Contact Rating (SPST)	1/2 HP @ 115 VAC (17 AMPS MAX)	1 HP @ 115 VAC (17 AMPS MAX)	1 HP @ 240 VAC (17 AMPS MAX)	3 HP @ 240 VAC (17 AMPS MAX)	480 VA @ 240 VAC
Weight	.63 lbs (.28 kg)	1.6 lbs (.73 kg) w/enclosure	.63 lbs (.28 kg)	1.6 lbs (.73 kg)	
Enclosure	None	NEMA 3R	None	NEMA 3R w/ LENS	
Current Transformer Ratio	N/A	N/A	N/A	N/A	SPP-235-75 - 50:5 SPP-235-100 - 75:5 SPP-235-150 - 100:5

OPERATING POINTS

Overload	125 % of Calibration Point				
Underload (Dry Run)	~80% of Calibration Point				
Overvoltage Trip Point	132.5 VAC	265 VAC			
Undervoltage Trip Point	95 VAC	190 VAC			
Number of Restarts allowed in a 60 sec Period before lockout (Rapid Cycle Timer)	4				
Trip Delay Time (Overload)	5s				
Trip Delay Time (Dry Run)	2s				

RESTART DELAY TIME

Overvoltage/Undervoltage Delay	5s				
All other faults (Dry Run Rec. Timer)	2-225 min				

TERMINAL

Wire Gauge	N/A			12-22	
Maximum Torque				7 in-lbs	

SECTION 12: MOTOR PROTECTIVE DEVICES - 50/60 HZ

11.3 MOUNTING AND INSTALLATION

Mount the Pentek® Motor Protector in a convenient location in or near the motor control panel. If the location is wet or dusty, then the Pentek Motor Protector should be mounted in a NEMA 3R, 4, or 12 enclosure.

11.4 WIRING CONNECTIONS

1. Connect one line from the fused disconnect to the Motor protector's "L1 IN" terminal. Run a wire from the "L1 OUT" terminal to the other in-line controls such as a pressure or float switch. See Figure 11-1.
2. Connect the other line from the fused disconnect to Motor Protector "L2 IN" terminal. Run a wire from the "L2 OUT" terminal to the other in-line controls such as pressure or float switches. See Figure 11-1.

The Motor Protector may not detect a dead head (blocked pipe) condition on applications where the pump is undersized for a given motor or flow restrictors are used on high stage pumps or low yield wells.

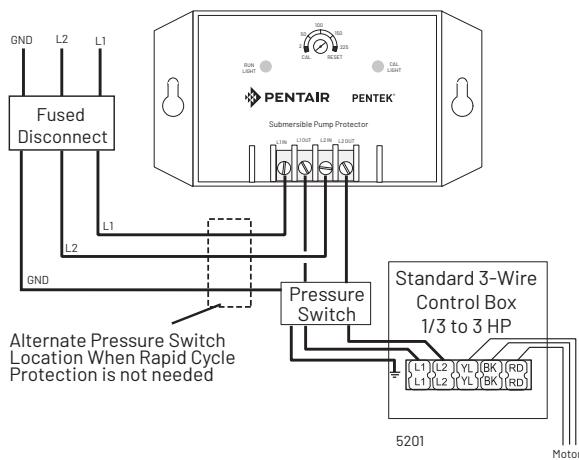

Figure 11-1: SPP233 Standard Control Box Connection

CALIBRATION/SETTINGS

NOTE: Calibrate the Motor Protector during normal pumping conditions.

1. Turn the RESTART DELAY / CALIBRATION adjustment fully counter-clockwise to the "CAL." position.
2. Apply power to the Motor Protector. The pump motor should be running at this point.
3. The Motor Protector is being calibrated when the CAL. LIGHT turns on (approximately 5 seconds). Within 10 seconds, proceed to step 4.
4. Set the RESTART DELAY / CALIBRATION adjustment to the desired Restart Delay (Dry Well Recovery Time). If you leave the RESTART DELAY / CALIBRATION adjustment in the "CAL." position, the unit will trip off and stay off. Turn the adjustment out of the "CAL." position to start the pump.

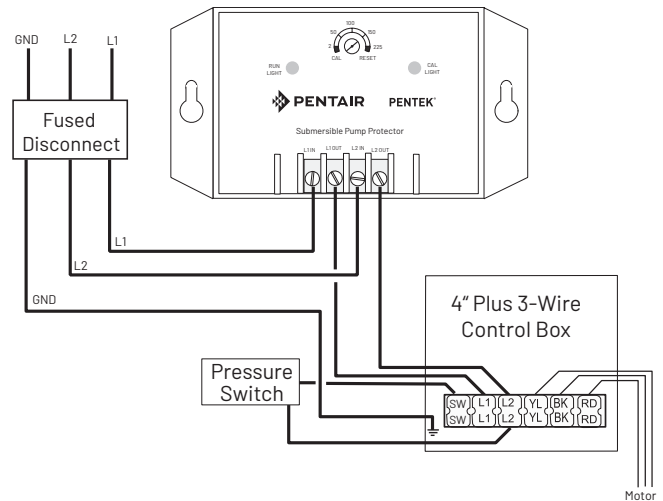

Figure 11-2: "Plus" Control Box Connection for SPP233

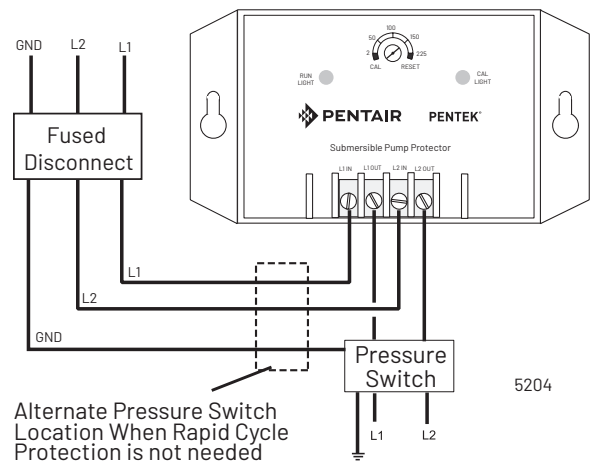

Figure 11-3: Two-Wire Connection for SPP233

Manual Reset Mode: If the RESTART DELAY / CALIBRATION adjustment is set to "RESET", the Motor protector is in Manual Reset mode. After the Motor Protector shuts down due to a voltage or load problem, the RESTART DELAY / CALIBRATION adjustment must be rotated out of the "RESET" position to restart the pump.

Any restart delay can be by-passed by rotating the RESTART DELAY / CALIBRATION adjustment to the "RESET" position and back to the desired Restart Delay setting.

Rapid Cycling Protection: Rapid cycling is defined as more than four restarts in a 60 second period. The Motor Protector will lockout upon detecting a rapid cycling condition until power is removed and re-applied to the L1 IN and L2 IN terminals. See Diagnostics Table for instructions to diagnose a rapid cycling fault.

SECTION 12: TROUBLESHOOTING

12.1 PUMP AND MOTOR PROBLEM ANALYSIS

PROBLEM	POSSIBLE CAUSE	CHECK AND RESTORE
Pump Won't Start.	No voltage (check with voltmeter). Typically will be no startup noise.	<ol style="list-style-type: none"> 1. Main power supply off. 2. Blown fuse or tripped circuit breaker. 3. Wiring damage, loose connection. 4. Burnt contactor points.
	Locked pump.	<ol style="list-style-type: none"> 1. Check for sand in system. 2. Crooked well (submersible).
Overloads Trip.	Low or high voltage.	<ol style="list-style-type: none"> 1. Check with voltmeter. ($\pm 10\%$ of nameplate voltage). Request power company correct problem. 2. Determine if wire size is correct for voltage and amperage.
	High ambient temperature or direct sunlight.	<ol style="list-style-type: none"> 1. Improve cooling for motor and controls. 2. Use ambient compensated overloads.
	Incorrect pump sizing – mismatched motor.	<ol style="list-style-type: none"> 1. Check pump (gpm) make sure near B.E.P. – “Best Efficiency Point”. 2. Recheck pump and motor model numbers prior to installation. Keep a written record.
	High cycling rate.	<ol style="list-style-type: none"> 1. Pressure control equipment malfunction. 2. Hole in piping system. 3. Pressure/storage tank failure.
	Damaged motor control.	<ol style="list-style-type: none"> 1. Check components per troubleshooting.
Fuses Blow or Breaker Trips.	Short or Ground.	<ol style="list-style-type: none"> 1. Fuses give superior protection and should be used in preference to circuit breakers when possible. 2. Inspect wiring for visible signs of heat damage (discoloration, damage to insulation). 3. Disconnect power and check with ohmmeter or megohmmeter to ground.
	Improper sizing.	<ol style="list-style-type: none"> 1. Consult manufacturer's information / sizing chart for proper size and replace as required.
Low or No Water Production.	No rotation.	<ol style="list-style-type: none"> 1. Motor not turning (see “Pump won't start” above). 2. Broken shaft coupling. Ammeter will show “low” amps.
	Restriction in piping.	<ol style="list-style-type: none"> 1. Check valve sticking. 2. Check valve installed backward. 3. Broken check valve poppet or flapper lodged in piping system downstream.
	Plugged inlet.	<ol style="list-style-type: none"> 1. Intake screen encrusted with minerals. 2. Insufficient clearance between pump and well casing for high capacity pump. Calculate intake velocity and limit to less than 5 feet per second.

SECTION 12: TROUBLESHOOTING

PUMP AND MOTOR PROBLEM ANALYSIS (CONTINUED)

PROBLEM	POSSIBLE CAUSE	CHECK AND RESTORE
Low or no water production (continued).	Well drawdown.	<ol style="list-style-type: none"> 1. Install air line upon reinstalling unit if not already present for measuring depth with tire pump and gage. 2. Measure dynamic (drawdown) level with string or resistance meter. 3. Select different pump if appropriate.
	Well collapsed.	<ol style="list-style-type: none"> 1. Unit is pumping dirty or sandy water. 2. Lift with pump hoist, check pull weight and resistance.
	Pump selection.	<ol style="list-style-type: none"> 1. Recheck operating conditions by comparing to pump curve. 2. Operate within ± 5 percentage points of efficiency from B.E.P.
	Hole in well piping.	<ol style="list-style-type: none"> 1. Listen for sucking sound at well head when pump shuts off. 2. Well pipe empties when submersible pump is pulled from well.
	Wrong rotation.	<ol style="list-style-type: none"> 1. Three phase motor - exchange any two of the three leads in the three phase motor starter panel. 2. Single phase motor - recheck motor and control panel wiring diagrams. Change wiring as appropriate. 3. Proper rotation for motors for sub. and centrifugal pumps with CW rotation is CCW when looking at the shaft end of the motor. 4. Make a visual flow check or observe flow meter. Amperage is not a reliable indicator of wrong rotation.
	Improper sizing.	<ol style="list-style-type: none"> 1. Consult manufacturer's performance charts or curves.
	Hole in distribution piping.	<ol style="list-style-type: none"> 1. Observe pressure loss with system shut off. 2. Look for wet spot or depression along pipe path.
Pump runs all the time.	Drawdown.	<ol style="list-style-type: none"> 1. Check for surging, irregular amperage readings with amprobe. 2. Look for bursts of air in water. 3. Listen for surging sounds in piping.
	Control equipment.	<ol style="list-style-type: none"> 1. Control equipment incorrectly selected or installed. 2. Welded electrical contact points. 3. Pressure switch supply pipe/tube plugged with rust/scale/ice. 4. ⚠ WARNING HAZARDOUS PRESSURE AND RISK OF EXPLOSION AND SCALDING. If pump is running continuously at no flow (with discharge shut off), water may boil in pump and piping system. Under steam pressure, pipes may rupture, blow off of fittings or blow out of pump ports and scald anyone near.
	Pump wear.	<ol style="list-style-type: none"> 1. Check amperage - generally lower unless severe bearing damage has occurred. 2. Verification may require removal of pump for service and visual inspection.

SECTION 12: TROUBLESHOOTING

PUMP AND MOTOR PROBLEM ANALYSIS (CONTINUED)

PROBLEM	POSSIBLE CAUSE	CHECK AND RESTORE
Electric shock.	Grounded wiring or motor.	<ol style="list-style-type: none"> 1. PROCEED WITH CAUTION! 2. Remove rings and other jewelry from hands before working with live power circuits. 3. Wear insulated boots and gloves. 4. Disconnect the power, check with ohmmeter. 5. Progressively check wire at each splice point (or obvious damage point). 6. When ground disappears, the fault is behind the point of discovery. 7. Check motor leads to motor shell with cable splice removed to determine if ground fault is in motor or supply cable.
	Moisture.	<ol style="list-style-type: none"> 1. Protect motor, motor starter and control devices from condensation or direct water spray.
Ammeter reads high on two leads, zero on the 3rd.	Three phase motor "single phasing".	<ol style="list-style-type: none"> 1. One power lead is not live or online. 2. Check with local utility company to see if having problems. 3. Check local power installation for transformer problems. 4. Will not be able to observe this condition very long. Very destructive to motor windings. Motor stator will soon be destroyed if single phasing protection is not installed. 5. This problem usually requires a replacement motor. 6. Determine source, install or replace protective gear.
Overload trip – ammeter reads high on all leads.	Binding or dragging.	<ol style="list-style-type: none"> 1. High volume of sand or other abrasives in well. Check by observing water output. 2. Severe damage to motor thrust bearing due to cavitation or abrasives. Usually very noisy. 3. Damage to motor control system.
	Power supply problems.	<ol style="list-style-type: none"> 1. Check with voltmeter while pump is running for $\pm 10\%$ voltage variance. 2. Extreme grounding of motor or supply cable. Check with ohmmeter or megohmmeter. 3. Poor wiring connections. Check splice, and terminal screws for looseness. Watch for discolored cable.

SECTION 12: TROUBLESHOOTING

12.2. MOTOR TROUBLESHOOTING FLOW CHARTS

Troubleshooting Flow Chart

Follow the arrow from the symptom on the left, to the inspection in the middle box.
If the middle box describes to symptom, proceed to the box on the right for the solution.

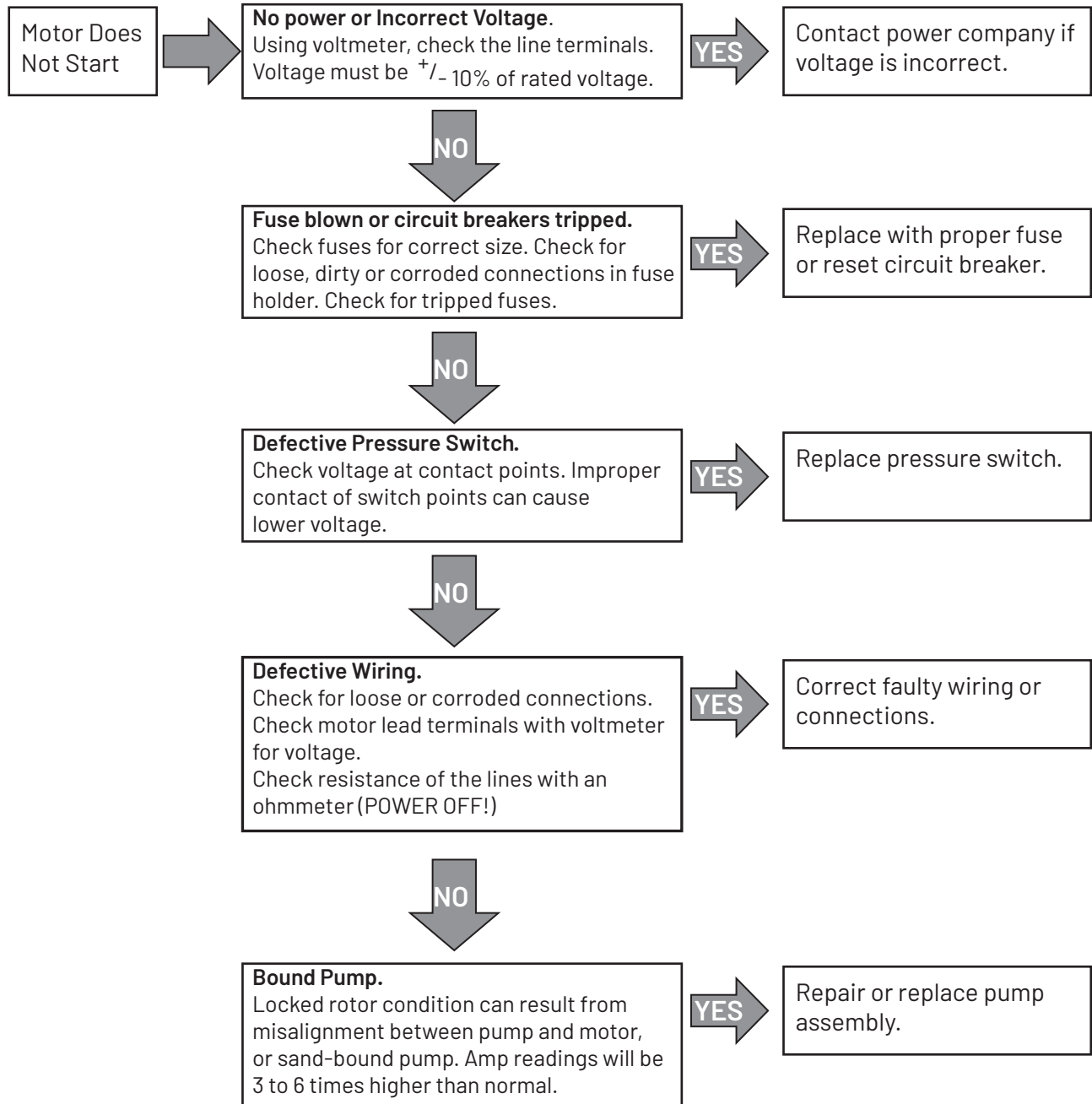

SECTION 12: TROUBLESHOOTING

MOTOR TROUBLESHOOTING FLOW CHARTS (CONTINUED)

Troubleshooting Flow Chart (Continued)

Follow the arrow from the symptom on the left, to the inspection in the middle box.
If the middle box describes to symptom, proceed to the box on the right for the solution.

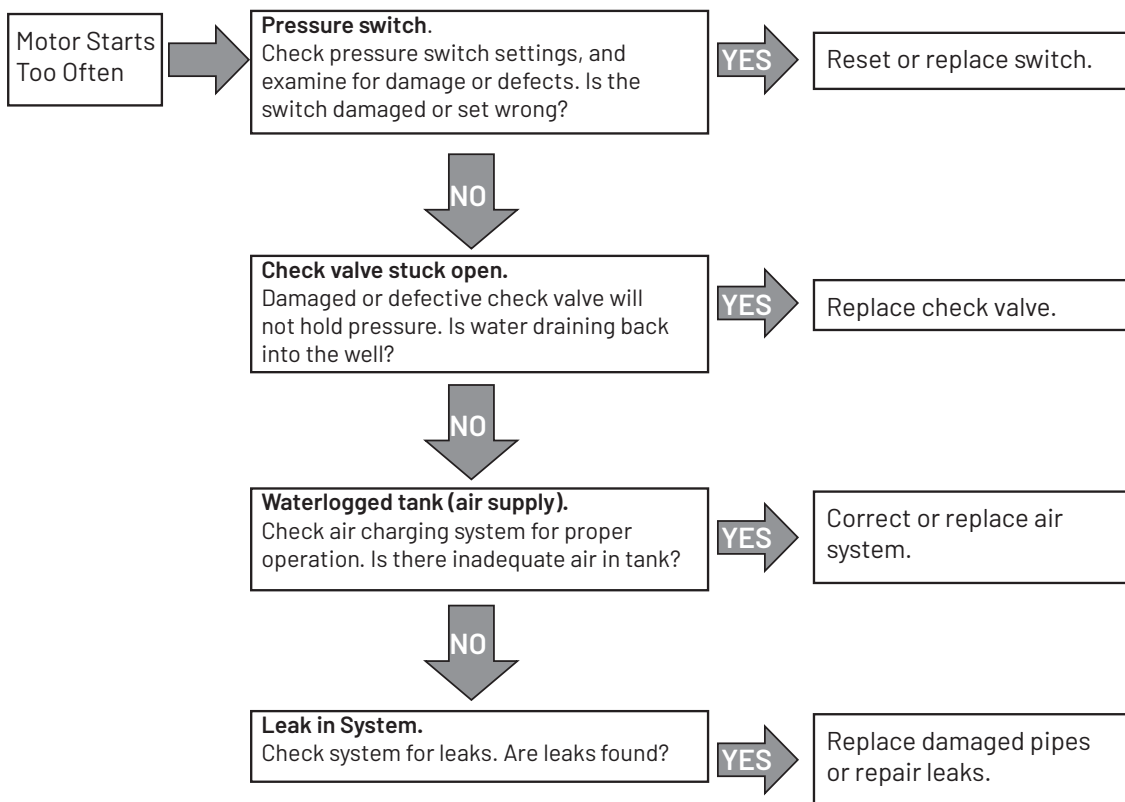

SECTION 12: TROUBLESHOOTING

MOTOR TROUBLESHOOTING FLOW CHARTS (CONTINUED)

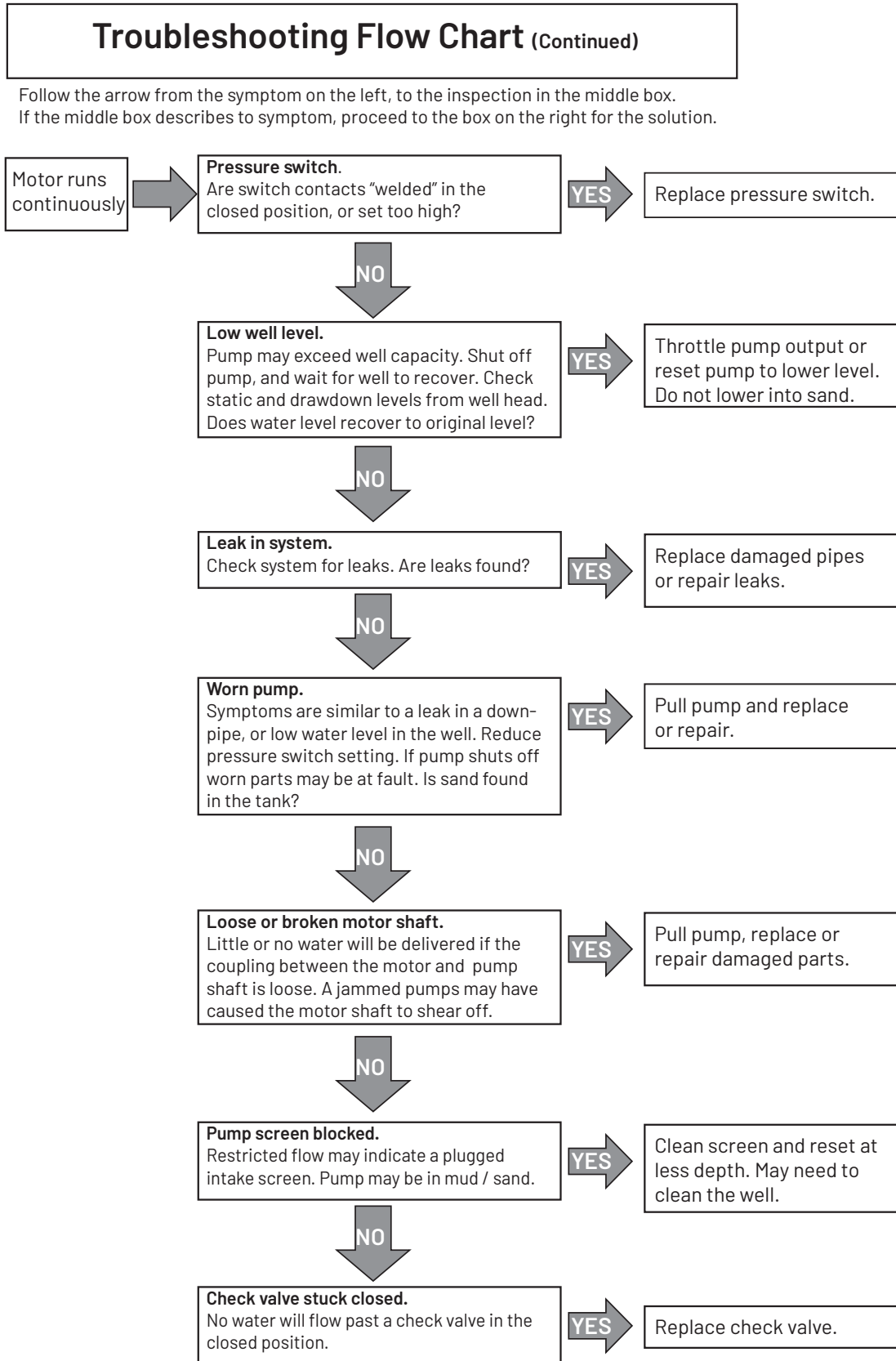

SECTION 12: TROUBLESHOOTING

MOTOR TROUBLESHOOTING FLOW CHARTS (CONTINUED)

Troubleshooting Flow Chart (Continued)

Follow the arrow from the symptom on the left, to the inspection in the middle box.
If the middle box describes to symptom, proceed to the box on the right for the solution.

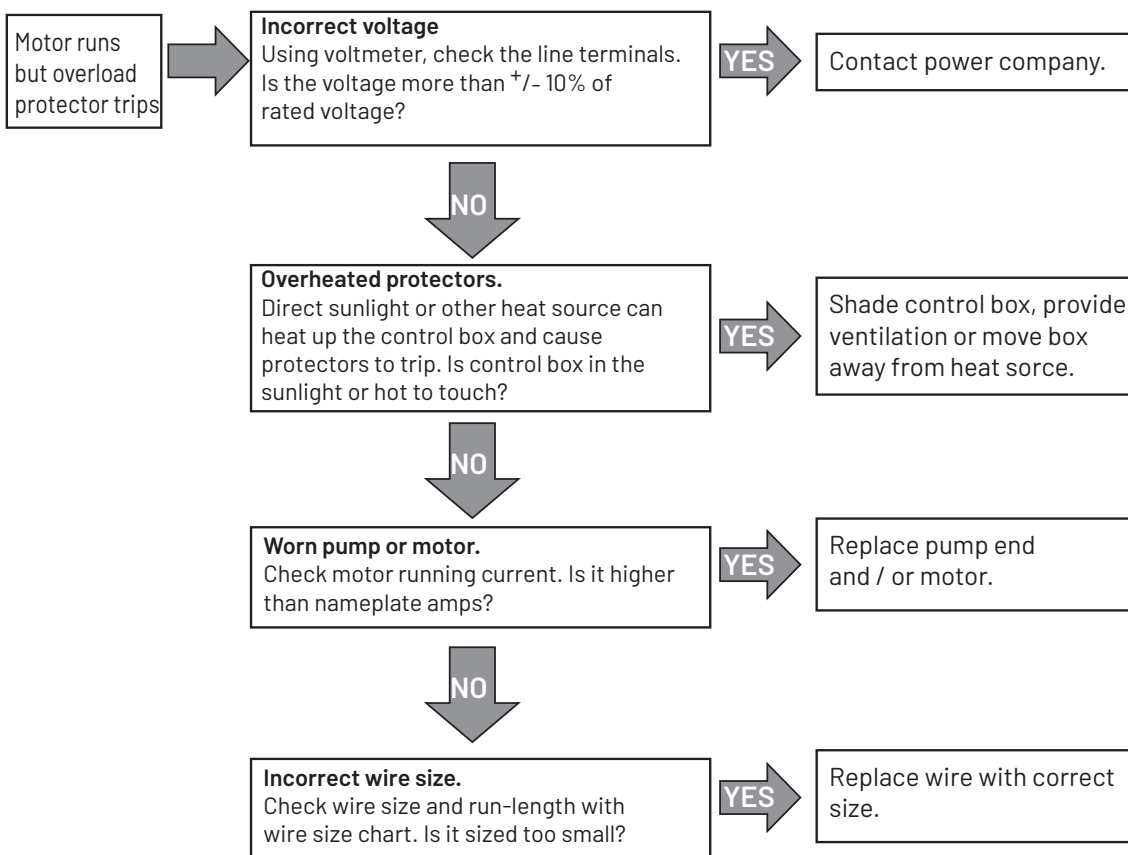

SECTION 12: TROUBLESHOOTING

12.3 TESTING SUBMERSIBLE MOTOR INSULATION AND WINDING RESISTANCE

INSULATION RESISTANCE

1. Turn off power!
2. Set the ohmmeter to RX100K ohms.
3. Zero the ohmmeter.
4. Connect one lead to the metal drop pipe (or to ground if the pipe is plastic).
5. Connect the other lead to any motor lead.
6. Check each power lead.
7. Compare results to the following table.

RESISTANCE	INDICATES
20K ohm	Damaged motor, possible result of lightning strike.
500K ohm	Typical of older installed motor in well.
2 M ohm	Newly installed motor.
10 M ohm	Used motor, measured outside of well.
20 M ohm	New motor without cable.

WINDING RESISTANCE

1. Turn off power!
2. Set the ohmmeter to RX1 ohm range. For values over 10, use the RX10 ohm scale.
3. Zero the ohmmeter.
4. Compare results to resistance shown in motor specifications table.

THREE PHASE MOTORS

Measure each line to each other (three readings). Compare these to the line-to-line resistance shown in motor specification table.

- ◆ If all leads measure within the table specifications, the leads and motor are okay.
- ◆ If a lead shows a higher resistance, then there is an open in the cable or winding. Check for secure cable connections.
- ◆ If a lead shows lower resistance, then there is a short circuit in the cable or winding.

SINGLE PHASE MOTORS: THREE-WIRE

- ◆ Measure the main winding (black to yellow).
- ◆ Measure the start winding (red to yellow).
- ◆ Compare these readings with the motor specification table.
- ◆ If the readings vary widely (some high, some low), the leads may be switched. Confirm that the cable colors are correct.

SINGLE PHASE MOTORS: TWO-WIRE

- ◆ Measure the resistance between the two lines.
- ◆ Compare the reading with the motor specification table.
- ◆ If the reading shows a high resistance, there may be an open in the cable or motor. Check for secure cable connections.
- ◆ If the reading shows very low resistance, there may be a short in the cable or motor.

SECTION 12: TROUBLESHOOTING

12.4 SMART PUMP PROTECTOR TROUBLESHOOTING

RUN LIGHT	CAL. LIGHT	PROBLEM OR FUNCTION	CORRECTIVE ACTION
On Steady	Off	RUN: Pump is running, no problems in operation.	None
On Steady	On Steady	CAL: The motor protector is in the calibration process.	None
Off	On Steady	CAL COMPLETE: The motor protector is calibrated, RESTART DELAY / CALIBRATION pot was left in "CAL." position. Pump is off.	Pump will restart as soon as the RESTART DELAY / CALIBRATION pot is rotated out of the "CAL." position.
Off	Off	OFF / MANUAL RESTART: The motor is not running. Either the Motor protector has tripped on dry run, dead head, or overload while the RESTART DELAY / CALIBRATION pot was in the "RESET" position, or source power is not present.	If pot is in the "RESET" position, rotate out of that position. If the "CAL" light blinks, check for an overload condition. If the RUN" light blinks, look for a dry run or dead head condition. If no lights come on, check incoming power for adequate voltage.
Blinking	Off	DRY RUN / DEAD HEAD: The motor protector has shut the pump off due to a dry run or dead head condition. The unit is timing through the restart delay and will try to restart.	Check for restricted flow or inadequate supply of liquid.
Off	Blinking	OVERLOAD: The motor protector has shut the pump off due to an overload condition. The unit is timing through the restart delay and will try to restart if line voltage is at an acceptable level.	Check for low or high voltage or jammed pump impeller. If these conditions do not exist, recalibrate the unit while it is drawing higher amps (Amps should not exceed SFA).
Blinking alternately with the CAL. Light.	Blinking alternately with the RUN Light.	VOLTAGE FAULT: The motor protector is preventing the pump from starting due to voltage problems. The voltage is being monitored and the unit will remain in this mode until the voltage is at an acceptable level.	If the unit remains in this state for more than 5 seconds, check for high or low voltage.
Blinking in unison with the CAL. Light.	Blinking in unison with the RUN Light.	RAPID CYCLE: The motor protector has shut down on rapid cycling. Power must be removed and reapplied to reset the unit.	Check for broken bladder on the pressure tank (if used), or check for defective pressure or float switch.

SECTION 12: TROUBLESHOOTING

12.5 SUBMERSIBLE CONTROLS TROUBLESHOOTING

INDIVIDUAL COMPONENT DIAGNOSTICS

Potential Relays: Using ohm meter - Coil Resistance (2 to 5) should measure according to the specification printed on the wiring diagram.

Using ohm meter - Contact resistance (1 to 2) should measure close to zero; higher values indicate deterioration of the contacts.

When the SMC first starts a faint click should be heard very shortly after the pump activates.

Start Capacitor: Using a capacitor meter - measured capacitance should be within +20% of the rating printed on the capacitor (or consult parts list for ratings).

Using ohm meter - the meter should quickly show low resistance (ohms) and move slowly to show higher resistance. Resistance should not be zero or open.

Physical Inspection - A foul smell or a buildup of black soot indicates that a start capacitor has vented usually because of heat or prolonged use.

Run Capacitor: Using a capacitor meter - measured capacitance should be within +/- 6% of the rating printed on the capacitor (or consult parts list for ratings).

Using ohm meter - the meter should quickly show low resistance (ohms) and move slowly to show higher resistance. Resistance should not be zero or open.

Physical Inspection - Run capacitors have a built in fail safe device that disconnects the capacitor in case of overheat, in the case of such an event the capacitor will bulge.

Overloads: Push overload to ensure that it is reset. Using ohm meter - connection resistance should measure close to zero.

Magnetic Contactor: Using ohm meter - Coil Resistance should measure per specification on wiring diagram.

Using ohm meter - Resistance between T1 & L1 and T2 & L2 should measure close to zero with contacts manually closed. Greater values indicates degradation of contacts.

Physical Inspection - Contacts should be free to move up and down.

MEASUREMENTS WHILE RUNNING

Small Box: Measurements cannot be taken while running, line voltage can be monitored with the cover off, by placing a voltmeter across L1 & L2. Winding resistance can be taken while motor is connected and should correspond to manufacturers specification.

⚠ WARNING FATAL ELECTRICAL SHOCK HAZARD. Only qualified persons should perform the following procedure.

Medium and Large Box: To take measurements while running, remove the cover. Turn on the pump and allow to cycle as usual. L1 to L2 should measure 230V +/- 10%, it should not dip during operation. A clamp-on ammeter can be used to measure amp draw along any number of circuits.

The larger yellow wire or main leads can be used to measure amp draw of the system, draw should spike and then come in less than 1 second. Orange lead amp draw should start out high and then drop out to become zero. If the reading stays high there is a relay problem.

The voltage between Red and Yellow should measure approximately 330V - higher values indicate no load; lower values indicate the motor (CSCR or PSC only) is not up to speed. Note that winding resistance cannot be measured while the motor is attached to the control box.

SECTION 12: TROUBLESHOOTING

SUBMERSIBLE CONTROLS TROUBLESHOOTING

PROBLEM	POSSIBLE CAUSE	CORRECTIVE ACTION
Pump fails to turn ON - no amp draw.	Damaged magnetic contactor, specifically the coil.	Plus Series only - replace coil.
	Damaged pressure switch.	All models - replace pressure switch.
	Loose connection.	Check to ensure that all connections are made and all screws tightened to 20 in-lbs.
	Damaged motor.	Check winding resistance.
Motor draws amps significantly higher than service factor.	Damaged relay (welded contacts, bad coil).	Replace relay.
	Wrong Control (e.g. 2 HP used on a 1 HP pump).	Install correct control.
	Bad run capacitor (blown).	Replace run capacitor.
	Miswired motor (e.g. Red and Black swapped).	Verify motor wiring.
	Voltage outside of operational norms.	Verify incoming voltage.
	Drop cable too small.	Replace drop cable with proper size wire for installation.
Overload trips within 10 seconds of Startup.	Locked (stalled) rotor condition.	Check installation.
	Miswired control.	Check to ensure connections match wiring diagram.
	Mis-matched motor & liquid end.	Verify installation.
	Wrong control used on motor.	Replace with correct control.
	Damaged relay.	Check per above.
	Damaged Start Capacitor.	Check per above.
Overload Trips After 10 seconds of Startup.	Rapid cycle.	Check installation.
	High ambient.	Do not mount in direct sunlight, provide proper ventilation.
	Damaged Run Capacitor.	Check per above.
	Chattering Relay/Bad Coil makes a clicking noise during operation.	Check per above.
	Wiring too small for current/drop length.	Check installation.
	Wrong control used on motor.	Replace with correct control.
Pump performance is low.	Installation/liquid end problem.	Check per installation manual.
	Damaged motor.	Verify and replace.
	Voltage outside of operational norms.	Check with voltmeter.
	Drop cable too small for run length.	Check installation.
	Damaged or Incorrect Run Capacitor.	Check per above.
	Wrong control used.	Replace with correct control.
Start capacitor vents contents.	Line voltage outside of operational norms.	Verify incoming voltage.
	Damaged relay.	Check and replace the relay or wires if they failed.
	Wire too small for drop length.	Use a low-voltage relay.

SECTION 13: APPENDIX

13.1 INSTALLATION CHECKLIST

This checklist can be used to preview and verify steps in the installation of Pentek® equipment. Refer to appropriate section of the manual for more information.

ELECTRICAL POWER

- Verify that the electrical service transformers KVA rating is adequate per the Table 4-2.
- Verify that motor voltage and frequency on the nameplate match the power supply voltage.
- Verify that fuse sizes are appropriate for the installation.
- Verify that the pump, casing and power supply are all grounded.
- Inspect lightning arrestors for proper sized wire and grounding. Do not rely solely on a grounding rod in the earth.
- Verify that the cable size from the power supply box to the pump is the correct size. See tables in section 5-4.

MOTOR

- Lead Condition.
- Check insulation resistance.
- Verify nameplate information for the service needed.
- Verify that the motor is correctly sized to pump.
- Verify that fuses, heaters and other electrical components are appropriate for the amp load.
- Fluid level.

PUMP AND MOTOR ASSEMBLY

- Verify pump shaft rotation.
- Verify that the pump rating matches the site requirements.
- Visually inspect pump and motor for electrical lead condition and splice condition.

INSTALLATION

- Verify that the pipe joints are tight.
- Verify that check valves have been installed.
- Verify that the cable is supported with straps or tape at least every 10 feet (3.05 m).
- Pump cooling.
- Start the pump and observe any noise, vibration, leaks or overheating.
- Verify that the pump performance is as specified, that the electrical current is balanced and within specifications.

CHECK VALVES

Check valve installation is necessary for proper pump operation. The pump should have a check valve on its discharge, or within 25 feet (7.62 m) of the pump. For very deep wells, locate a check valve at least every 200 feet (61 m).

- ◆ DO NOT install the check valve midway between the pump and the ground surface. Vibration in the piping will resonate and may damage or destroy the piping or pump. Adjust check valve spacing to avoid a mid-point placement.
- ◆ Use only spring type check valves. Swing type valves can cause water hammer problems.
- ◆ Do not use drain-back style check valves (drilled).

CHECK VALVES SERVE THE FOLLOWING PURPOSES:

- ◆ Maintain Pressure: Without a check valve, the pump has to start each cycle at zero head, and fill the down pipe. This creates upthrust in the motor, and would eventually damage both the pump and motor.
- ◆ Prevent Water Hammer: If two check valves are used, and the lower one leaks, then a partial vacuum forms in the pipe. When the pump next starts, the flow fills the void area quickly and creates a shock wave that can break piping and damage the pump.
- ◆ Prevent Back-Spin: Without a functioning check valve, upon shutoff, the water drains back through the pump, and cause it to rotate backwards. This can create excessive wear on the thrust bearing, and if the pump restarts as water is flowing down the pipe, it will put an excessive load on the pump.

SECTION 13: APPENDIX

13.2 CHOOSING A PUMP SYSTEM

A typical well application can be set up using one of three electrical configurations for single-phase power. The samples below are based upon a system using a 1.5 HP, 20-22 gpm pump, with 400 feet of wire from electrical disconnect to the motor. All configurations shown are suitable methods for residential applications.

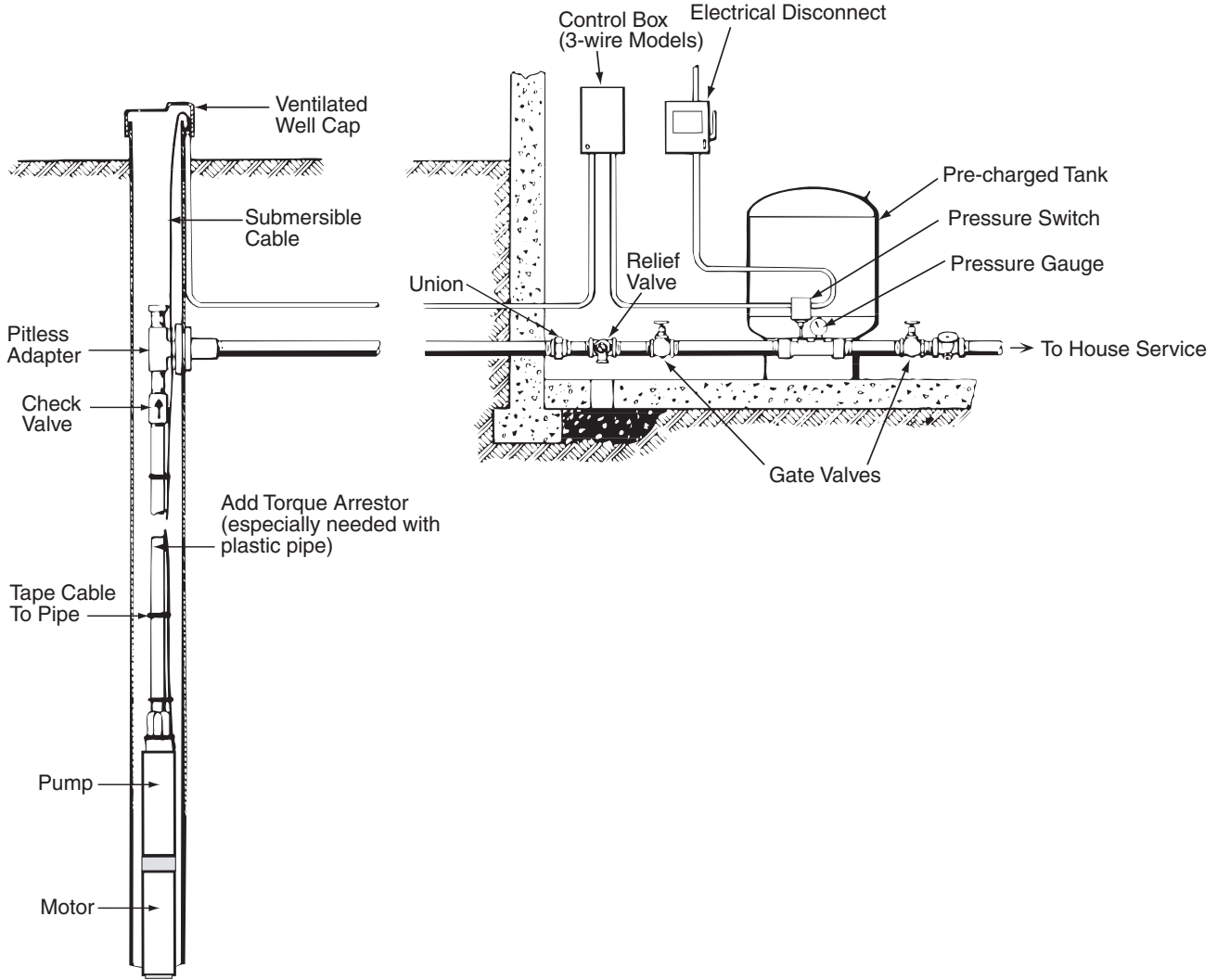

“GOOD” SYSTEM

Features

- ◆ Pressure Switch
- ◆ Wire, (10-2 w/ground)
- ◆ 1.5 HP, 20-22 gpm pump
- ◆ 1.5 HP, two-wire motor
- ◆ 85 gal. Tank
- ◆ Optional Motor Protection (SPP-233P)

Benefits

- ◆ Cost
- ◆ Simple to use
- ◆ PENTEK PSC motor offers lower operating cost.

“BETTER” SYSTEM

Features

- ◆ Control Box
- ◆ Pressure Switch
- ◆ Wire, (10-3 w/ground)
- ◆ 1.5 HP, 20-22 gpm pump
- ◆ 1.5 HP, three-wire motor
- ◆ 85 gal. Tank
- ◆ Optional Motor Protection (SPP-233P)

Benefits

- ◆ Capacitors and switches can be replaced without removing pump.
- ◆ CSCR control offers higher efficiency.
- ◆ Higher starting torque than two-wire.

“BEST” SYSTEM

Features

- ◆ VFD
- ◆ Pressure Transducer
- ◆ Wire, (12-3 w/ground)
- ◆ 1.5 HP, 20-22 gpm pump
- ◆ 1.5 HP, three-phase motor
- ◆ 6 gal. Tank

Benefits

- ◆ “City-like” pressure
- ◆ Lower operating costs
- ◆ Soft start/stop
- ◆ Motor protection built into VFD.

SECTION 13: APPENDIX

13.3 SIZING SUBMERSIBLE PUMP, MOTOR, AND TANKS

SIZING A SUBMERSIBLE PUMP

The following steps should be taken relative to properly sizing the system.

1. Determine gpm of system and well.
2. Size of well casing and type.
3. Determine service pressure requirements.
4. Determine voltage and phase.
5. Determine discharge pipe size.
6. Calculate friction head loss.
7. Determine (total discharge) head.
8. Select the submersible pump for the above criteria, and appropriate controls for the pump.
9. Select the proper size tank for minimum one minute pump run time.
10. For starting frequency, refer to Section 5.10.
11. Determine the distance from the service entrance panel to the pump motor.
12. Determine the size wire required based on the motors maximum load amps and the distance from the service entrance to the motor.

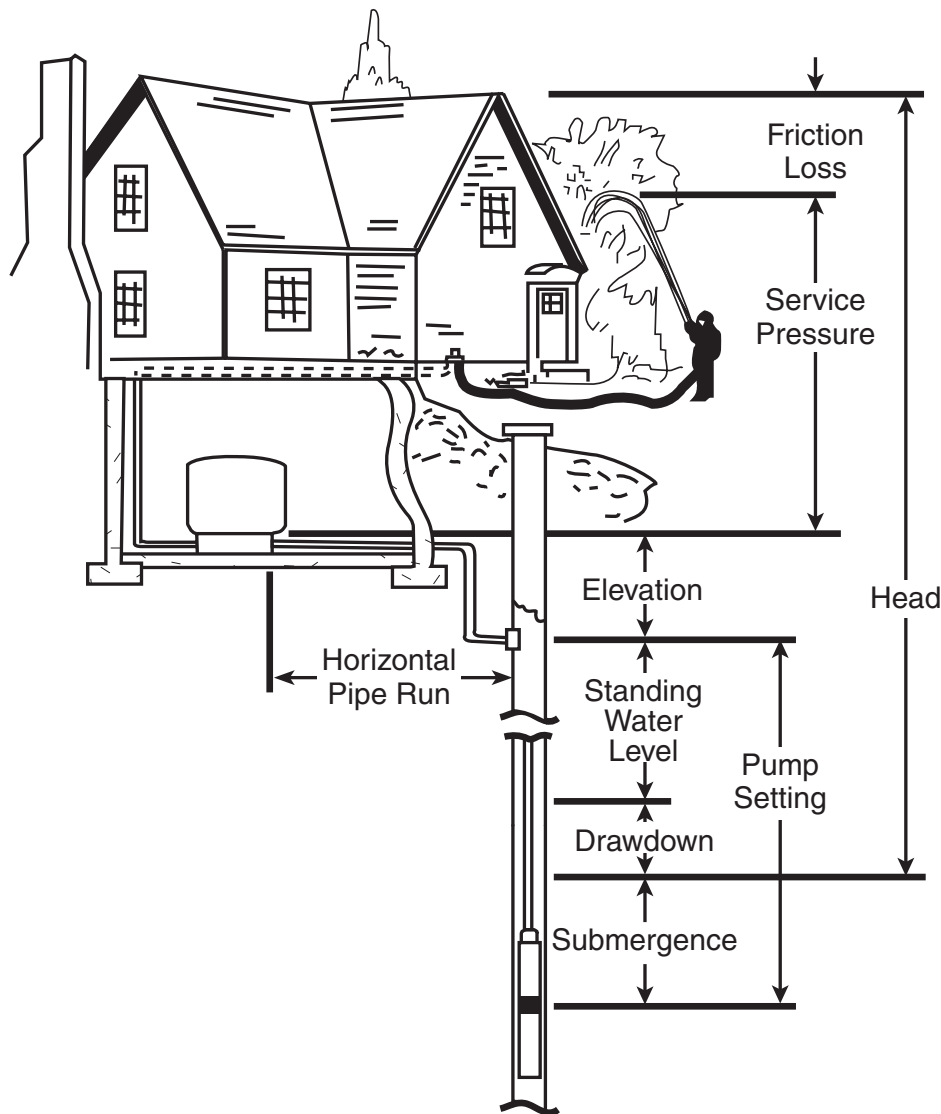

Figure 13-1: Common Pump Terminology

SECTION 13: APPENDIX

13.4 SELECT THE CORRECT PUMPING EQUIPMENT

The answer to four basic questions will help select the proper pump:

- What is the size of the well?** The inside diameter of the well must be known so that the proper size pump and drop pipe can be determined.
- What is the submergence?** The vertical distance in feet from the pump to the water level while the pump is operating (see Figure 13-1). If the pump is installed away from the well and is on higher ground, this elevation must also be included. This must not be confused with the standing water level.
- What should the average discharge pressure be?** Usual average discharge pressure is 50 lbs. – half way between the 40 lbs. to 60 lbs. switch setting of most water systems. More pressure is needed when the tank is installed away from the pump and at a higher level, or when house or yard fixtures are above the pump and tank, and a larger pump must be used.
- What capacity is required?** The discharge capacity of the pump in gallons per minute that is needed for satisfactory service. The pump should have enough capacity so that it can deliver the total water requirement in 2 hours of continuous operation. See Table 13-1 for average water requirements.

INSTALLATION TERMINOLOGY

- ♦ **Standing or Static Water Level** – distance from top of well to natural water level when pump is not operating.
- ♦ **Drawdown Distance** – distance water level drops while pump is operating.
- ♦ **Drawdown or Pumping Water Level** – standing water level plus drawdown.
- ♦ **Submergence** – distance submersible pump intake screen is installed below drawdown level.
- ♦ **Elevation** – vertical distance between top of well and service inlet.
- ♦ **Pump Setting** – distance from top of well to pump inlet screen.
- ♦ **Service Pressure** – pressure required (in PSI) at service inlet.
- ♦ **Friction Loss** – loss of pressure due to friction of water flowing through pipe and fittings.
- ♦ **Head** – discharge head (in feet) delivered when pump is operating at desired capacity.
- ♦ **Horizontal Pipe Run** – horizontal distance between service inlet and well.
- ♦ **“Top of Well”** also means “Pitless Adapter Level” or well exit.
- ♦ **“Service Inlet”** also means “Storage Tank Inlet”.

SELECTING A PUMP

TIP: PSI can be converted to equivalent feet of head by multiplying by 2.31.

i.e. 60 psi = 138.6 feet of head

To choose a motor for your submersible pump you first must know:

- ♦ Flow required in Gallons per Minute.
- ♦ Total head (Pumping level, friction losses and service pressure required).

Friction loss must be calculated, and depends upon total length, diameter and type of pipe plus additions for each fitting (valves, elbows...) in the line.

Refer to the product catalog for friction loss charts.

AVERAGE WATER REQUIREMENTS FOR GENERAL SERVICE AROUND THE HOME AND FARM

Each person per day, for all purposes.....	50 gal.
Each horse, dry cow or beef animal.....	12 gal.
Each milking cow.....	35 gal.
Each hog per day.....	4 gal.
Each sheep per day.....	2 gal.
Each 100 chickens per day.....	4 gal.

AVERAGE AMOUNT OF WATER REQUIRED BY VARIOUS HOME AND YARD FIXTURES

Drinking fountain, continuously flowing.....	50 to 100 gal. per day.
Each shower bath	Up to 60 gal.
To fill bathtub.....	30 gal.
To flush toilet.....	2.5-6 gal.
To fill lavatory.....	2 gal.
To sprinkle 1/4" of water on each 1000 square feet of lawn.....	160 gal.
Dishwashing machine, per load.....	3 gal.
Automatic washer, per load.....	Up to 50 gal.
Regeneration of domestic water softener.....	50-100 gal.

AVERAGE FLOW RATE REQUIREMENTS BY VARIOUS FIXTURES

(gpm equals gal. per minute, gph equals gal. per hour).

Fixture	New (at 60 PSI)	Older Style
Shower	2.5 gpm	4 to 6 gpm
Bathtub	3 gpm	4 to 8 gpm
Toilet	1.6 gpm	4 to 5 gpm
Lavatory	2.5 gpm	1 to 3 gpm
Kitchen sink	2.2 gpm	2 to 3 gpm
1/2" hose and nozzle.....		200 gph.
3/4" hose and nozzle.....		300 gph.
Lawn sprinkler.....		120 gph.

SECTION 13: APPENDIX

EXAMPLE

Assume we want 16 GPM at 60 PSI from a pump drawdown level (pumping level) 100 feet below the service inlet.

We have a 35 foot horizontal run of 1 1/4" plastic pipe with two gate valves and four 90° elbows.

To find the Friction losses we must refer to friction loss charts for pipe and fittings.

We find:

- ◆ 135 feet of pipe for the total pipe run (100 + 35).
- ◆ 10 equivalent feet of pipe for the gate valves (2 x 5).
- ◆ 28 equivalent feet of pipe for the elbows (7 x 4).
- ◆ Add these for the total equivalent length of pipe = 173.
- ◆ In the friction loss charts, find the loss of head for 173 feet of 1 1/4" pipe at 16 gpm. (3.96 per 100') = 3.96 x 1.73 = 6.8 (round to 7.0).

Add: 7 Friction loss
 100 Pumping level
 139 60 PSI service pressure required (60 x 2.31=138.6. Round to 139)
 = 246 Total Dynamic Head.

From this sample curve we would choose the 1 1/2 HP pump.

Locate a pump with a best efficiency point near the desired flow rate (16 GPM) that meets the total head requirements (246 TDH).

Selecting a pump in this manner gives you the most efficient pump for your application.

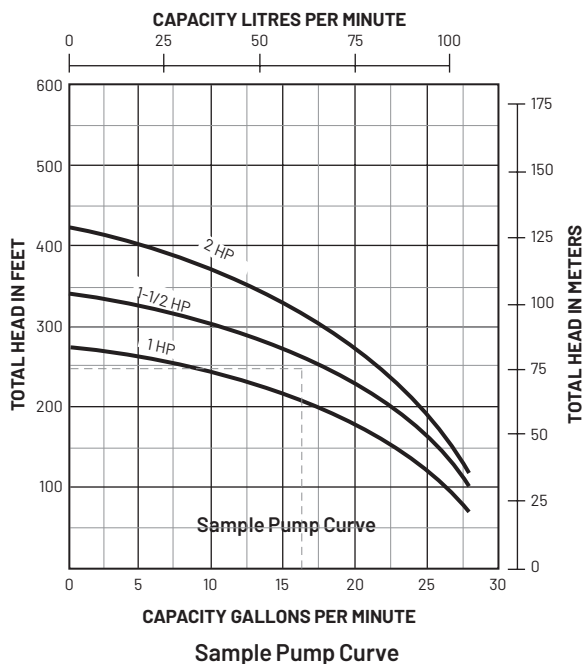

13.5 SIZING TANKS

Tank should be sized to accommodate starting frequency in Section 5.10.

Refer to the dealer catalog for tank selection. Otherwise, the following procedure can be used.

DRAWDOWN BASED ON BOYLE'S LAW

Procedure:

1. Identify drawdown multiplier relating to specific application.
2. Insert multiplier (X) into the following formula:

$$\frac{\text{Pump GPM} \times \text{Min Run Time}}{\text{Multiplier (X)}} = \text{Minimum Tank Capacity Required}$$

Example: An example of a 20 GPM pump with a minimum run time of 1 minute, installed on a 50 - 70 PSIG system pressure range:

$$\frac{20 \text{ GPM} \times 1 \text{ minute}}{.24 \text{ (factor)}} = 83.3 \text{ minimum U.S. gallon tank capacity}$$

Drawdown will be affected by operating temperature of the system, accuracy of the pressure switch and gauge, the actual pre-charge pressure and the rate of fill.

TABLE 13-2: DRAWDOWN VOLUME MULTIPLIER (APPROXIMATE)

PUMP OFF PRESSURE PSI	PUMP START PRESSURE - PSI							
	10	20	30	40	50	60	70	80
20	0.26							
30	0.41	0.22						
40		0.37	0.18					
50		0.46	0.31	0.15				
60			0.40	0.27	0.13			
70			0.47	0.35	0.24	0.12		
80				0.42	0.32	0.21	0.11	
90				0.48	0.38	0.29	0.19	0.10
100					0.44	0.35	0.26	0.17

TANK SIZING FOR VARIABLE FREQUENCY DRIVES

Variable Frequency Drives (VFD) may require slightly different methods for figuring tank size. Refer to Section 8 for VFD information.

SECTION 13: APPENDIX

13.6 RECORD OF INSTALLATION

OUTSIDE POWER:

Transformer 1 _____ KVA

Transformer 2 _____ KVA

Transformer 3 _____ KVA

CABLES

From Service Entrance to Pump Control:

Size _____ AWG/MCM

Length _____ ft.

Temp. Rating _____ °F / °C (circle one)

Check appropriate boxes

- Copper Aluminum
- Jacketed Individual Conductors

FROM PUMP CONTROL TO MOTOR:

Size _____ AWG/MCM

Length _____ ft.

Temp. Rating _____ °F / °C (circle one)

Check appropriate boxes

- Copper Aluminum
- Jacketed Individual Conductors

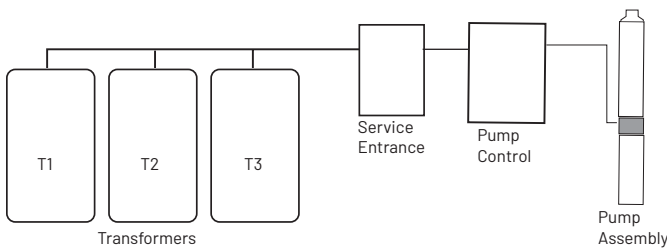

PUMP MOTOR CONTROL PANEL

Manufacturer / Model _____

Circuit Protection:

- Circuit Breaker: _____ Amps
- Fuse _____ Amps
- Std. _____ Delay _____

Starter:

Manufacturer _____ Size _____

Type:

- Autotransformer
- Full Voltage
- Other _____

Time to full voltage _____ sec.

HEATERS

Manufacturer _____

Qty: _____ Amp setting _____

Installation Data

Controls grounded to:

- Motor Well Head
- Power Supply Buried Rod

Grounding wire size _____ AWG / MCM

Date _____

Location _____

Motor serial number:

MOTOR CURRENT - BALANCE WORKSHEET

	ARRANGEMENT 1 AMPS	ARRANGEMENT 2 AMPS	ARRANGEMENT 3 AMPS
	L1-T1 =	L1-T3 =	L1-T2 =
	L2-T2 =	L2-T1 =	L2-T3 =
	L3-T3 =	L3-T2 =	L3-T1 =
TOTAL AMPS			
AVERAGE AMPS			
FROM AVERAGE AMPS			
Deviation L1	_____	_____	_____
Deviation L2	_____	_____	_____
Deviation L3	_____	_____	_____
% CURRENT UNBALANCE LARGEST DEVIATION			
% UNBALANCE +	_____ %	_____ %	_____ %

SECTION 13: APPENDIX

RECORD OF INSTALLATION

Installer _____
 Address _____
 City _____ State _____ Zip _____
 Phone _____ Fax _____
 E-mail _____
 Who to contact? _____
 Owner _____
 Address _____
 City _____ State _____ Zip _____
 Phone _____ Fax _____
 E-mail _____
 Who to contact? _____

INSTALLATION

Well Identification _____
 Water Temperature _____
 Date Installed _____
 Signature _____

PUMP INFORMATION

Model _____
 GPM _____ @ft. TDH
 PSI _____
 Date code _____

MOTOR NAMEPLATE INFORMATION

Manufacture _____
 Model _____
 HP _____
 Voltage _____
 Phase _____
 Max Amps _____
 Date code _____
 Serial Number _____

VFD (VARIABLE FREQUENCY DRIVE) INFORMATION

Drive Manufacturer _____
 Model Number _____
 Input Filters _____
 Output Filters _____

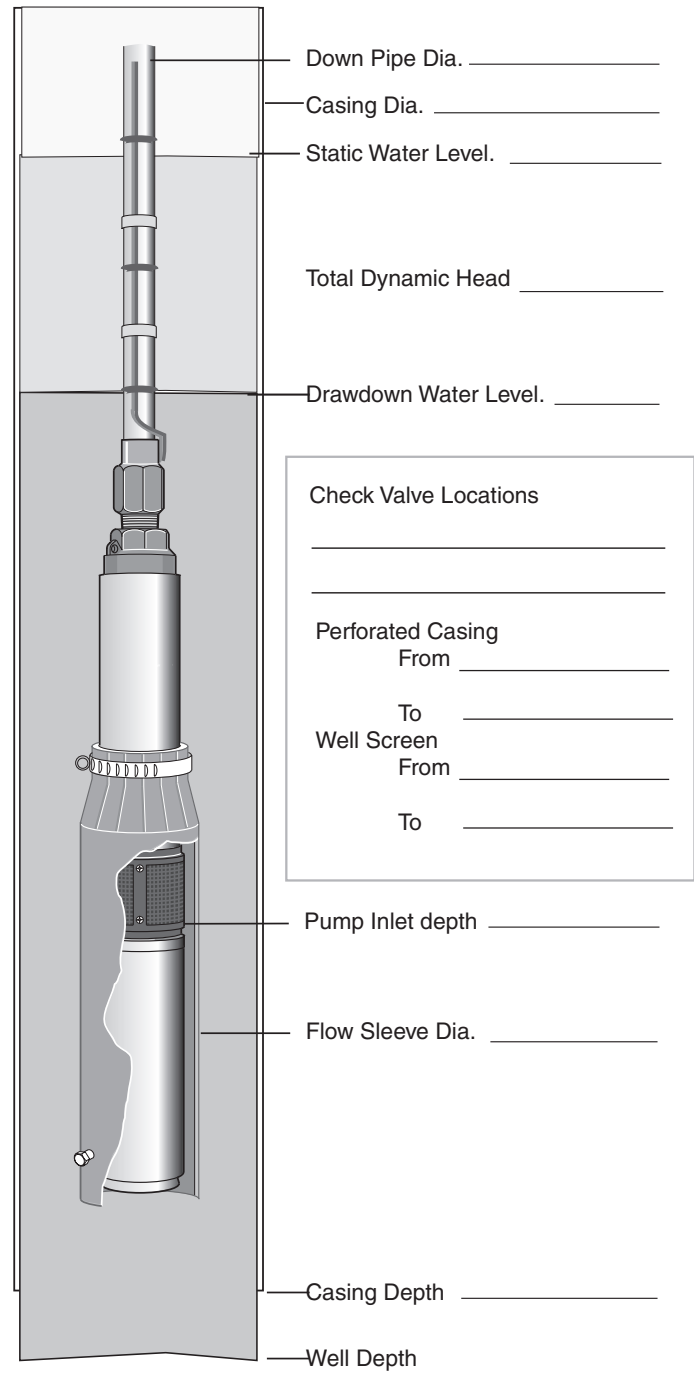

PENTEK WARRANTY

PENTAIR warrants to the original consumer purchaser ("Purchaser" or "You") of the products listed below, that they will be free from defects in material and workmanship for the Warranty Period shown below.

PRODUCT	WARRANTY PERIOD
Water Systems Products – jet pumps, small centrifugal pumps, submersible pumps and related accessories	Whichever occurs first: 1. 12 months from date of original installation, 2. 18 months from date of manufacture
Pentek Intellidrive® Pentek® Solar Drive	12 months from date of original installation, or 18 months from date of manufacture
Pro-Source® Composite Tanks	5 years from date of original installation
Pro-Source Steel Pressure Tanks	5 years from date of original installation
Pro-Source Epoxy-Line Tanks	3 years from date of original installation
Sump/Sewage/Effluent Products	12 months from date of original installation, or 18 months from date of manufacture

Our warranty will not apply to any product that, in our sole judgment, has been subject to negligence, misapplication, improper installation, or improper maintenance. Without limiting the foregoing, operating a three phase motor with single phase power through a phase converter will void the warranty. Note also that three phase motors must be protected by three-leg, ambient compensated, extra-quick trip overload relays of the recommended size or the warranty is void.

Your only remedy, and PENTAIR's only duty, is that PENTAIR repair or replace defective products (at PENTAIR's choice). You must pay all labor and shipping charges associated with this warranty and must request warranty service through the installing dealer as soon as a problem is discovered. No request for service will be accepted if received after the Warranty Period has expired. This warranty is not transferable.

PENTAIR IS NOT LIABLE FOR ANY CONSEQUENTIAL, INCIDENTAL, OR CONTINGENT DAMAGES WHATSOEVER. THE FOREGOING LIMITED WARRANTIES ARE EXCLUSIVE AND IN LIEU OF ALL OTHER EXPRESS AND IMPLIED WARRANTIES, INCLUDING BUT NOT LIMITED TO IMPLIED WARRANTIES OF MERCHANTABILITY AND FITNESS FOR A PARTICULAR PURPOSE. THE FOREGOING LIMITED WARRANTIES SHALL NOT EXTEND BEYOND THE DURATION PROVIDED HEREIN.

Some states do not allow the exclusion or limitation of incidental or consequential damages or limitations on how long an implied warranty lasts, so the above limitations or exclusions may not apply to You. This warranty gives You specific legal rights and You may also have other rights which vary from state to state.

This Limited Warranty is effective October 3, 2019 and replaces all undated warranties and warranties dated before October 3, 2019.



293 Wright Street
Delavan, WI 53115
Ph: 866.973.6835
Fx: 800.426.9446

490 Pinebush Rd., Unit 4
Cambridge, Ontario
Canada N1T 0A5
Ph: 800.363.7867
Fx: 888.606.5484

pentair.com

All indicated Pentair trademarks and logos are property of Pentair. Third party registered and unregistered trademarks and logos are the property of their respective owners. Because we are continuously improving our products and services, Pentair reserves the right to change specifications without prior notice. Pentair is an equal opportunity employer.

Pentek Intellidrive is a registered trademark of Pentair.®
Hitachi® is a registered trademark of Hitachi Industrial Equipment Systems Co., Ltd.
Scotchfil™ and Scotch® are registered trademarks of the 3M Company.
GE is the registered trademark of General Electric Company.