

HYDROMATIC® CSS-3D AND CSS-3V SUMP BASIN PACKAGE

Preplumbed Sump Basin Package

- Basement sumps, dewatering, new or existing installations
- Fully Assembled Check valve included.
- Injection-Molded Structural Foam Provides the highest quality construction for uniform wall thickness and strength.
- Proprietary "Flush Mount" Design for easy shipping and storage. Allows for pallet stacking.

The Hydromatic Preplumbed Sump Basin Package is a rugged, high quality product consisting of our D-A1 or V-A1 .3 HP Cast Iron sump pump, ideal for drain water removal. The 18" x 22" basin is constructed of the highest quality structural foam and has a 20 gallon capacity. The package comes with a single-piece structural foam lid, proprietary "Flush Mount" design for easy shipment and storage. The unit comes field-ready with 1-1/2" NPT threaded discharge flange and a 2" NPT vent flange (adaptable to 3") and includes a 1-1/2" sump check valve.



HYDROMATIC® CSS-3D AND CSS-3V SUMP BASIN PACKAGE

Specifications

Pump (D-A1 or V-A1)

- Housing – Cast iron.
- Motor – .3 HP, 115 volt, single phase, shaded pole motor, built-in overload protection.
- Maximum Limits – Liquid temperature: 120°F (49°C).

Basin, Lid, and Accessories

- Radon Proof – Radon approved basin and cover for radon prevention.
- Basin – Injection-molded structural foam (polyethylene). 20-gallon capacity. Standard 18" x 22" basin.
- Lid – Injection-molded structural foam (polyethylene). Gas-tight single-piece design with seal.
- Hub Adapter – 4" Snap-in type with stainless steel clamp. Fits 4" DWV SCH. 40 plastic pipe.
- Flanges – 1-1/2" NPT threaded discharge and 2" NPT vent flange (easily converts to 3"). Comes with gas-tight cord grommet.
- Check Valve – Sump pump check valve fits 1-1/2" black, galvanized, and DWV SCH. 40 pipe.

Performance Curve

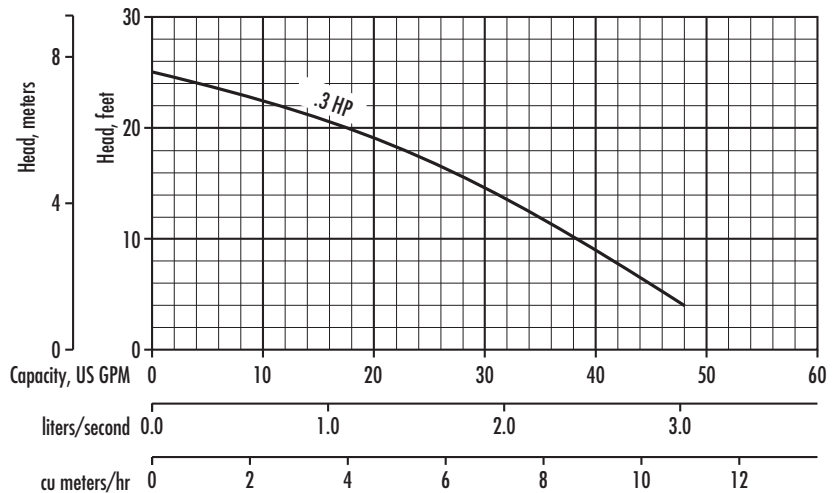

Sectional View

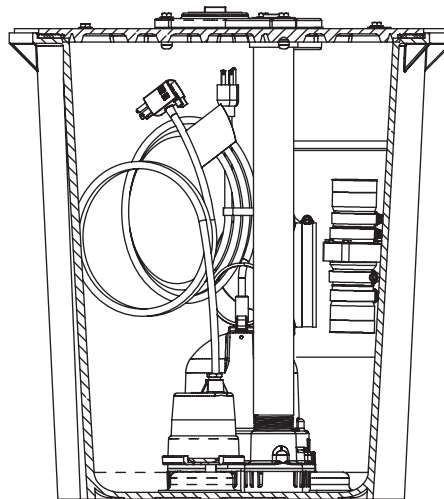

Outline Dimensions

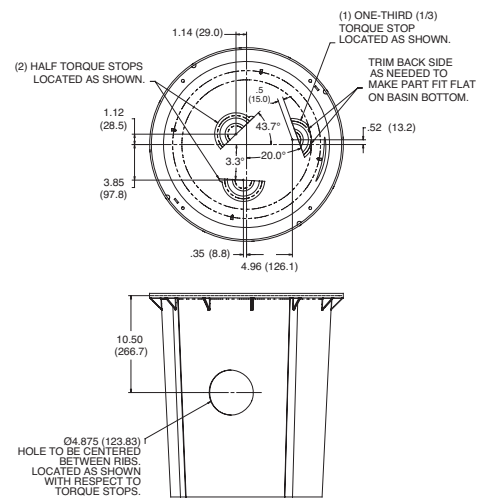

Ordering Information

Catalog Number	HP	Package Type	Full Load Amps	Cord Length	Mechanical Switch Type	Basin Size
CSS-3D	.3	Preassembled	12	10'	Diaphragm	18" x 22"
CSS-3V	.3	Preassembled	12	10'	Vertical	18" x 22"



USA
293 WRIGHT STREET, DELAVAN, WI 53115 WWW.HYDROMATIC.COM
PH: 888-957-8677 ORDERS FAX: 800-426-9446

CANADA
269 TRILLIUM DRIVE, KITCHENER, ONTARIO, CANADA N2G 4W5
PH: 519-896-2163 ORDERS FAX: 519-896-6337

Because we are continuously improving our products and services, Pentair reserves the right to change specifications without prior notice.