

HYDROMATIC® HTS33 SERIES CAST IRON SUBMERSIBLE HIGH TEMPERATURE EFFLUENT PUMPS

Applications:

- Boiler Blow Down Kits
- Condensate Pits
- Hot Water Sumps

The HTS33 Series Pump is a rugged, submersible, cast iron pump with a non-clog vortex impeller and solids handling capability to 3/4". Unit has 1/3 HP, 115 Volt, single-phase motor and 1 1/2" NPT vertical discharge. Available with high temperature float switch.



HYDROMATIC® HTS33 SERIES CAST IRON SUBMERSIBLE HIGH TEMPERATURE EFFLUENT PUMPS

Pump Characteristics

Pump/Motor Unit	Submersible	
Motor	1/3 HP, 1550 RPM, Oil-filled, Built-in thermal overload protection with automatic reset.	
Electrical	115V, 1ø, 12A, 60 Hz	
Models	HTS33M1	HTS33A1
Switch Type	Manual	Tethered
Maximum Liquid Temperature	200°F (93°C)	194°F (90°C)
Operation	Automatic On: 13.5" (343 mm) Off: 4.5" (114 mm)	
Solids Handling	3/4" spherical solid	
Power Cord	20' oil and water resistant 16-3 SJ00W-A/SJOW with integrally grounded three-prong plug	

Materials of Construction

Motor/Volute Housing	Cast Iron
Mechanical Seal	Type 6A or equal, Buna-N elastomers, carbon and ceramic sealing faces, stainless steel metal parts
Impeller	Cast Iron
Exterior Hardware	Stainless Steel
Lower Motor Housing O-Ring	Buna-N
Bearings	Lower ball, upper sleeve type, oil lubricated

Performance Data

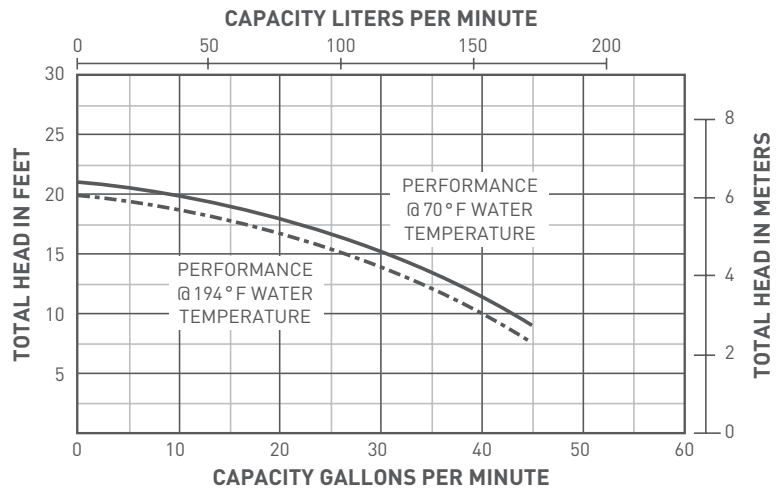

Dimensional Data

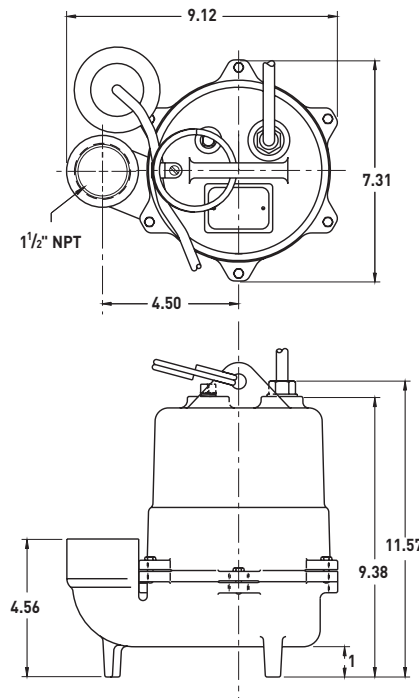

All dimensions in inches. Metric for international use. Component dimensions may vary ± 1/8 inch. Dimensional data not for construction purpose unless certified. Dimensions and weights are approximate. On/Off level adjustable.



USA
293 WRIGHT STREET, DELAVAN, WI 53115 WWW.HYDROMATIC.COM
PH: 888-957-8677 ORDERS FAX: 800-426-9446

CANADA
269 TRILLIUM DRIVE, KITCHENER, ONTARIO, CANADA N2G 4W5
PH: 519-896-2163 ORDERS FAX: 519-896-6337

Because we are continuously improving our products and services, Pentair reserves the right to change specifications without prior notice.